

Trigonometry Lecture Notes

David M. McClendon

Department of Mathematics
Ferris State University

2026 edition
©2026 David M. McClendon

Contents

Contents	2
1 Pre-trigonometry	4
1.1 What is allowed? What isn't allowed?	4
1.2 Solving basic equations	6
1.3 Functions	10
2 Trigonometry foundations	16
2.1 Introduction to trigonometry	16
2.2 Linear measurements	18
2.3 The coordinate plane	21
2.4 Vector operations	25
2.5 Angles	31
2.6 Solving angle pictures	36
2.7 Pythagorean Theorem	38
2.8 Standard position of an angle	43
2.9 Radian measure	51
2.10 Applications of radian measure	57
3 Sine, cosine and tangent	64
3.1 Unit circle definitions	64
3.2 Angle definitions	71
3.3 Computing sines and cosines with a calculator	75
3.4 Basic identities	80
3.5 Reflection properties	83
3.6 Sines, cosines and tangents of special angles	86
3.7 Arcsine, arccosine and arctangent	95
4 Triangle trigonometry	105

4.1	Law of Sines	107
4.2	Law of Cosines	119
4.3	SOHCAHTOA	125
4.4	Interpreting dot products	128
4.5	Area formulas for triangles	132
5	Oscillations and trig graphs	136
5.1	Review: what is a graph?	136
5.2	Graphs of $\sin x$ and $\cos x$	138
5.3	Transformations on sine and cosine	141
5.4	The graph of $y = \tan x$	154
6	Secant, cosecant and cotangent	156
6.1	Definitions	156
6.2	More on secant, cosecant and cotangent	163
6.3	Trig functions of special angles	167
6.4	Pythagorean identities	175
6.5	Graphs of cosecant, secant and cotangent	180
7	Trigonometric algebra	184
7.1	Elementary trig identities	184
7.2	Sum and difference identities	189
7.3	More identities	192
8	Homework exercises	195
8.1	Chapter 1 Homework	195
8.2	Chapter 2 Homework	202
8.3	Chapter 3 Homework	228
8.4	Chapter 4 Homework	252
8.5	Chapter 5 Homework	257
8.6	Chapter 6 Homework	265
8.7	Chapter 7 Homework	279

Chapter 1

Pre-trigonometry

1.1 What is allowed? What isn't allowed?

EXERCISE

Classify the following statements as true or false (in math, for a statement to be true means that it is always true):

- | | TRUE | FALSE | |
|-----|--------------------------|--------------------------|--|
| 1. | <input type="checkbox"/> | <input type="checkbox"/> | $5(x + 2) = 5x + 2.$ |
| 2. | <input type="checkbox"/> | <input type="checkbox"/> | $5(x + 2) = 5x + 10.$ |
| 3. | <input type="checkbox"/> | <input type="checkbox"/> | $(a + b)(x + y) = ax + by.$ |
| 4. | <input type="checkbox"/> | <input type="checkbox"/> | $3x = x + x + x.$ |
| 5. | <input type="checkbox"/> | <input type="checkbox"/> | $x^2 = x + x.$ |
| 6. | <input type="checkbox"/> | <input type="checkbox"/> | $3 \cdot \frac{1}{5} = \frac{3}{5}.$ |
| 7. | <input type="checkbox"/> | <input type="checkbox"/> | $\frac{a}{b} = a \cdot \frac{1}{b}.$ |
| 8. | <input type="checkbox"/> | <input type="checkbox"/> | $\frac{a+b}{c} = \frac{a}{c} + b.$ |
| 9. | <input type="checkbox"/> | <input type="checkbox"/> | $\frac{a+3}{2} = \frac{a}{2} + \frac{3}{2}.$ |
| 10. | <input type="checkbox"/> | <input type="checkbox"/> | $\frac{a}{b+2} = \frac{a}{b} + \frac{a}{2}.$ |

1.1. What is allowed? What isn't allowed?

- | | TRUE | FALSE | |
|-----|--------------------------|--------------------------|---|
| 11. | <input type="checkbox"/> | <input type="checkbox"/> | $\frac{2}{3} \cdot \frac{8}{7} = \frac{2 \cdot 8}{3 \cdot 7}$. |
| 12. | <input type="checkbox"/> | <input type="checkbox"/> | $\frac{2}{3} \div \frac{8}{7} = \frac{2 \div 8}{3 \div 7}$. |
| 13. | <input type="checkbox"/> | <input type="checkbox"/> | $x^2 = x \cdot x$. |
| 14. | <input type="checkbox"/> | <input type="checkbox"/> | $(xy)^2 = x^2y^2$. |
| 15. | <input type="checkbox"/> | <input type="checkbox"/> | $(x - 3)^2 = x^2 - 3$. |
| 16. | <input type="checkbox"/> | <input type="checkbox"/> | $(x - 3)^2 = x^2 - 3^2$. |
| 17. | <input type="checkbox"/> | <input type="checkbox"/> | $\left(\frac{x}{5}\right)^2 = \frac{x^2}{5}$. |
| 18. | <input type="checkbox"/> | <input type="checkbox"/> | $\left(\frac{x}{y}\right)^2 = \frac{x^2}{y^2}$. |
| 19. | <input type="checkbox"/> | <input type="checkbox"/> | $\sqrt{2x} = 2\sqrt{x}$. |
| 20. | <input type="checkbox"/> | <input type="checkbox"/> | $\sqrt{xy} = \sqrt{x}\sqrt{y}$. |
| 21. | <input type="checkbox"/> | <input type="checkbox"/> | $(x + 2)^2 = x^2 + 2$. |
| 22. | <input type="checkbox"/> | <input type="checkbox"/> | $(x + 2)^2 = x^2 + 4$. |
| 23. | <input type="checkbox"/> | <input type="checkbox"/> | $(x + y)^2 = x^2 + y^2$. |
| 24. | <input type="checkbox"/> | <input type="checkbox"/> | $\sqrt{x + y} = \sqrt{x} + \sqrt{y}$. |
| 25. | <input type="checkbox"/> | <input type="checkbox"/> | $\sqrt{x^2 + y^2} = x + y$. |
| 26. | <input type="checkbox"/> | <input type="checkbox"/> | $\frac{1}{2/3} = \frac{3}{2}$. |
| 27. | <input type="checkbox"/> | <input type="checkbox"/> | $\frac{1}{\left(\frac{5}{\sqrt{3}}\right)} = \frac{\sqrt{3}}{5}$. |
| 28. | <input type="checkbox"/> | <input type="checkbox"/> | $\frac{a}{\left(\frac{b}{c}\right)} = \frac{\left(\frac{a}{b}\right)}{c}$. |

1.2 Solving basic equations

Linear equations

A **linear equation** is an equation which, after some valid algebra, can be written as $ax = b$ for some numbers a and b . To solve a linear equation, you combine all the x -terms on one side of the equation and combine all the non- x -terms on the other side.

EXAMPLE 1

Solve for x , if $8x + 7 = 79$.

EXAMPLE 2

Solve for x , if $3(5 - 2x) = 7(x + 2)$.

Solving linear equations for expressions, rather than variables

Often, you have to solve for something more complicated than just “ x ”. The principle is the same as what we’ve done before, except you should think of the thing you are solving for as its own letter.

Be careful not to combine unlike terms! ($3 + 5x \neq 8x$, etc.)

EXAMPLE 3

Solve for $\sqrt{x + 1}$:

$$18\sqrt{x + 1} = 36$$

EXAMPLE 4

Solve for x^4 :

$$5 + 3x^4 = 2(7 - 5x^4)$$

EXAMPLE 5

Solve for $\cos x$ (whatever “ $\cos x$ ” means):

$$40^2 = 30^2 + 35^2 - 2(30)(35) \cos x$$

Solving proportions

A **proportion** consists of two fractions which are equal:

$$\frac{a}{b} = \frac{c}{d}.$$

To solve a proportion involving variables, you **cross-multiply** the proportion, applying the theoretical fact that

$$\frac{a}{b} = \frac{c}{d} \text{ if and only if } ad = bc.$$

EXAMPLE 6

Solve for x :

$$\frac{x}{3} = \frac{2.78}{8.44}$$

EXAMPLE 7

Solve for x :

$$\frac{x}{x-2} = \frac{7}{5}$$

EXAMPLE 8

Solve for $\sin x$ (whatever “ $\sin x$ ” means):

$$\frac{\sin x}{7.25} = \frac{.358}{10.459}$$

Solution: First, cross-multiply. Then, divide both sides by 10.459:

$$10.459 \sin x = .358(7.25)$$

$$10.459 \sin x = 2.5955$$

$$\sin x = \frac{2.5955}{10.459}$$

$$\sin x = .24816.$$

Quadratic equations

A **quadratic equation** has a variable squared (like x^2) in it.

How to solve a quadratic equation

If there is an x^2 term but no x term: solve for the x^2 term. Then take the square root of both sides (be sure to include both the positive and negative square root as answers for x).

If there is both an x^2 term and an x term: move all the terms of the equation to one side (i.e. make one side equal to zero). Then either factor or use the quadratic formula.

EXAMPLE 9

Solve each equation for x :

a) $x^2 + 3x = 40$

b) $x^2 = 36$

c) $x^2 + (.275)^2 = 1$

d) $x^2 + (1.275)^2 = 8.81$

Solution: First, square out the $(1.275)^2$ and move it to the other side:

$$x^2 + (1.275)^2 = 8.81$$

$$x^2 + 1.6256 = 8.81$$

$$x^2 = 8.81 - 1.6256$$

$$x^2 = 7.1844$$

$$x = \pm\sqrt{7.1844}$$

$$x = \pm 2.68.$$

1.3 Functions

QUESTION

What is a function? Don't peek at the next page. (My past experience is that many Math 120 students don't know what a function is.)

EXAMPLE 10

Suppose you buy soup at Meijer. Each can of soup costs 2 dollars, with the catch that cans of soup are "buy one, get one free". Let's create a "function" which models this situation; we'll call this function "price".

Definition 1.1 A **function** is a rule of assignment which produces outputs from inputs, in such a way that each input leads to one and only one output. The set of inputs to a function is called the **domain** of the function, and the set of outputs is called the **range** of the function.

We usually name functions after letters (capital or lowercase), but we also name them after words or phrases, and occasionally use a symbol to name a function.

A good way to think about a function is to think of an “arrow diagram”:

Definition 1.2 If f is a function, then $f(x)$ is the output associated to input x , not “ f times x ”. Sometimes the parenthesis in the $f(x)$ is omitted and we just write fx , especially if the function is named after a word or phrase, rather than a single letter. The formula defining $f(x)$ for an arbitrary input x is called the **rule** or **formula** for f .

EXAMPLE 11

Let f be the function which takes its input, squares it, then subtracts 8 to produce the output. Find a formula for f , and compute $f(2)$ and $f(-5)$.

IMPORTANT: To be a valid function, each input must have only one possible output.

EXAMPLE 11.5

Determine whether or not each given formula is the formula of a valid function:

- a) $f(x) = \pm x$
- b) $f(x) = (\pm x)^2$
- c) $f(x) = (\pm x)^3$

EXAMPLE 12

Let T be the function which takes its input, multiplies the input by 4 and then subtracts 3 to produce the output.

- a) Find a formula for $T(x)$.

- b) Compute $2T(3)$.

- c) Compute $T(2 \cdot 3)$.

- d) Compute $T(2 + 1)$.

- e) Compute $T(2) + T(1)$.

- f) Find a formula for $T(3x)$.

- g) Find a formula for $3T(x)$.

EXAMPLE 13

Let funny be the function defined as follows: start with input x . If $x = 0$, then funny $x = 5$. If x is positive, then funny $x = 1 + x$. If x is negative, then funny $x = 3 + 2x$.

- a) Compute funny 6.
- b) Compute funny -3 .
- c) Compute $-$ funny 3.
- d) Compute funny 2 + funny (-2) .
- e) Compute funny $(2 + (-2))$.
- f) Compute funny $(3 + 2)$.
- g) Compute funny 3 + funny 2.
- h) Compute funny 3 + 2.
- i) Compute funny $(2) \cdot 3$.
- j) Compute funny $(2 \cdot 3)$.
- k) Compute funny $2 \cdot 3$.
- l) Compute 3 funny 2.
- m) Compute funny $3 \cdot 2$.

Order of operations with functions and exponents

EXAMPLE 14

Suppose $\text{car } x = 3x - 1$. Compute each quantity:

a) $\text{car } 2^2$

b) $\text{car}^2 2$

c) $\text{car}^3 1$

d) $\text{car } 3^2 \cdot 2$

Solution: $\text{car } 3^2 \cdot 2 = \text{car } (9 \cdot 2) = \text{car } 18 = 3(18) - 1 = \boxed{53}$.

e) $2 \text{ car } 3^2$

Solution: $2 \text{ car } 3^2 = 2 \text{ car } 9 = 2 [3(9) - 1] = 2 [26] = \boxed{52}$.

f) $3 \text{ car}^3 (2 - 1)^2 + 5$

Substitutions in functional expressions

EXAMPLE 15

a) If you know $x = 3$, how does the expression $\text{cup } x + 1$ simplify?

(Put another way, how do you substitute " $x = 3$ " into " $\text{cup } x + 1$ "?)

b) If you know $\text{cup } x = 3$, how does the expression $\text{cup } x + 1$ simplify?

- c) If you know $x = 3$, how does the expression $\text{cup}(x + 1)$ simplify?
- d) If you know $\text{cup } x = 3$, how does the expression $\text{cup}(x + 1)$ simplify?
- e) If you know $x = 3$, how does the expression $\text{cup}^2 x$ simplify?
- f) If you know $\text{cup } x = 3$, how does the expression $\text{cup}^2 x$ simplify?

EXAMPLE 16

- a) Substitute $x = .3$ into $\text{dog}^2 x + \text{cat}^2 x = 1$.
- b) Substitute $\text{dog } x = .3$ into $\text{dog}^2 x + \text{cat}^2 x = 1$. Then solve for $\text{cat } x$.
- c) Substitute $\text{dog}^2 x = .3$ into $\text{dog}^2 x + \text{cat}^2 x = 1$. Then solve for $\text{cat } x$.

Chapter 2

Trigonometry foundations

2.1 Introduction to trigonometry

FIRST QUESTION

What is “trigonometry”?

SECOND QUESTION

What is trigonometry for?

1. Converting between rotational measurements and length measurements (astronomy, gears and wheels, pulleys, etc.)

Example: If you get on the Ferris wheel of radius 80 ft shown below and go $\frac{3}{5}$ of the way around, how high off the ground are you?

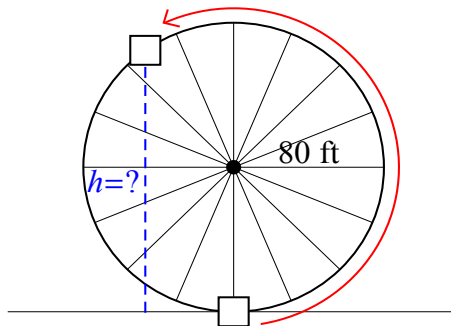

2. Determining lengths and angles by taking auxiliary measurements (architecture, landscaping, product design, etc.)

Example: Suppose the measurements below are known. What is x ?

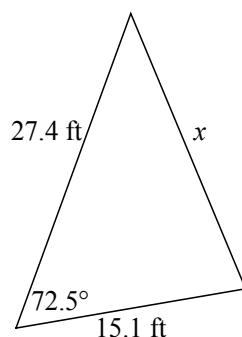

3. Studying oscillating behavior (sound and light waves, ocean waves, radiation, harmonics, signal processing, alternating currents, etc.)

Example: From the graph below, write an equation which gives the water depth in terms of the position, and use your equation to predict the water depth at position 300:

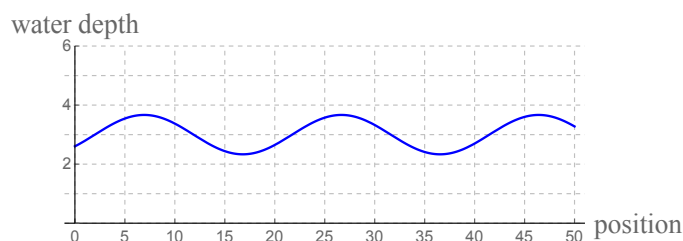

COURSE OUTLINE

In MATH 120, we will address each of these three classes of problems listed above:

Chapter 2 lays out foundational material needed for all the problems;

Chapter 3 is about the conversion between measurements of rotation and measurements of length;

Chapter 4 is about how to determine lengths and angles via auxiliary measurements;

Chapter 5 is about the description of oscillating behavior; and

Chapters 6 and 7 (we may not get to Chapter 7) contain some extra material related to trigonometric algebra, which is potentially useful in your future courses.

2.2 Linear measurements

Linear displacement

The **linear displacement** (or just **displacement**) of an object is the net change in its position. For instance, if you start at 6 in (on a number line), you go forward 7 inches and then backward 3 inches, your displacement is in. (Your ending position is in.)

In general, displacement = _____ minus _____ .

Numbers are meant to represent displacements, under the assumption you start at 0 and are moving along a number line:

positive numbers correspond to

negative numbers correspond to

addition corresponds to

multiplication by (-1) corresponds to

NOTE: If you end where you start, your linear displacement must be 0.

QUESTION

What happens if your motion is along a curve, rather than a straight line? How do you measure your linear displacement?

Linear velocity

The **linear velocity** (or just **velocity**) of an object is the rate of change of its linear displacement, which is given by its displacement divided by elapsed time:

$$velocity = \frac{displacement}{time}$$

EXAMPLE 1

A chipmunk runs across my yard at .85 yards per second.

- a) How far does it run in 3.5 seconds?

- b) How long would it take the chipmunk to run 25 yards?

EXAMPLE 2

If you drive 420 miles in 6 hours, what is your velocity (assuming that your velocity stays the same for the entire trip)?

Unit conversions

MOTIVATING EXAMPLE

You own 1000 clunks. If 13 clunks are equal to 7 doinks, then how many doinks do you have?

Theorem 2.1 (Unit conversions) Suppose A of unit a is equal to B of unit b . Then, to convert between these units, use the following scheme:

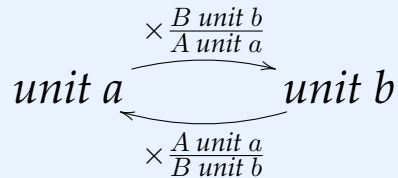

EXAMPLE 3

- a) Convert 2.5 miles to feet.

Solution: We know $1 \text{ mi} = 5280 \text{ ft}$, so $2.5 \text{ mi} = 2.5 \text{ mi} \cdot \frac{5280 \text{ ft}}{1 \text{ mi}} = \boxed{13200 \text{ ft}}$.

- b) Convert 80.605 grams to kilograms.

Solution: We know $1000 \text{ g} = 1 \text{ kg}$, so

$$80.605 \text{ g} = 80.605 \text{ g} \cdot \frac{1 \text{ kg}}{1000 \text{ g}} = \frac{80.605}{1000} \text{ kg} = \boxed{.080605 \text{ kg}}$$

- c) If 8 jokers are the same as 3 kings, how many kings are there in 19.35 jokers?

- d) Assuming that there are 2.54 cm in one inch, convert 18 yards to meters.

- e) How many inches per second are there in 0.35 miles per hour?

- f) If 15.2 tortes equal 8.35 unicorns and 17 yucks equal 5 zaps, convert 23.25 yucks per unicorn to zaps per torte.

2.3 The coordinate plane

QUESTION

In the last section we discussed how numbers on a number line represent linear displacement.

What happens if your motion is **two-dimensional**, meaning that instead of going forward and backward, you also are moving side-to-side (like you are running around in a field)? How do you record your position and/or displacement?

ANSWER

Ordered pairs

Just as real numbers can be thought of as points on a number line, **ordered pairs** (x, y) can be thought of as points in a plane. The first number in an ordered pair is called the **x -coordinate** and measures the **horizontal** distance the point (x, y) is from the origin; the second number in the pair is called the **y -coordinate** and measures the **vertical** distance that (x, y) is from the origin.

EXAMPLE 4

Graph the following points on the provided axes:

$(0, 3)$ $(-3, 4)$ $(2, -3)$ $(-4, 0)$ $(-1, -2)$

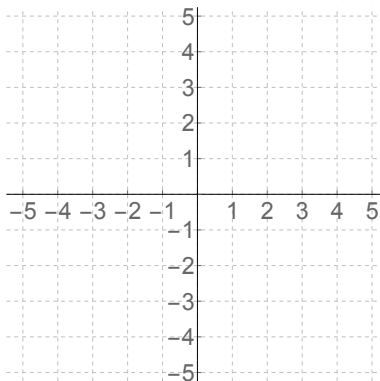

EXAMPLE 5

- a) Start at $(3, 8)$. Go left seven units, then up five units, then right three units. Where are you?
- b) What is the distance from $(2, 7)$ to the x -axis?
What is the distance from $(2, 7)$ to the y -axis?
- c) Describe the set of points in the coordinate plane whose y -coordinate is 2.
- d) What do all the points on the indicated line have in common?

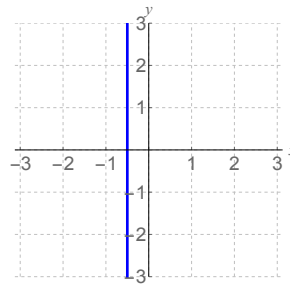

Quadrants

The x - and y -axes divide the coordinate plane into four **quadrants**, numbered by Roman numerals:

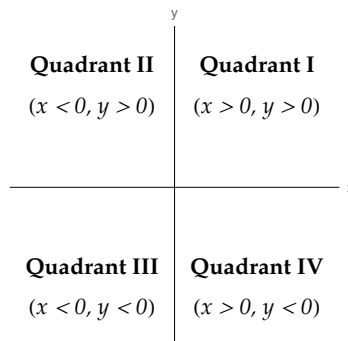

Introducing vectors

If we think of an ordered pair (or ordered n -tuple) as representing a **displacement** (i.e. the movement of an object) rather than a fixed position, then the ordered pair becomes a mathematical object called a *vector*:

Definition 2.2 A **scalar** is a number. A **vector** is a quantity which has two attributes: a size (called its **magnitude** or **norm** or **length**), and a *direction*.

Think of a vector as representing the net motion of an object. The *magnitude* of the vector is how far it moves, and the *direction* of the vector tells you what direction the object moves in. Two vectors are **equal** if they represent the same motion, i.e. they have the same magnitude and same direction.

Vectors are often represented pictorially by arrows. In this context, the place the vector starts is called the **initial point** of the vector, and the place the vector ends is called the **terminal point** of the vector. We can think of the vector as representing the **net motion** of an object going from the initial point to the terminal point.

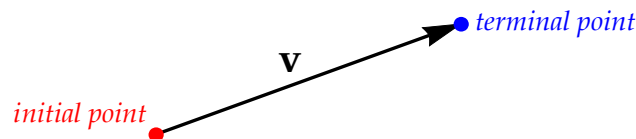

That said, vectors are really more like “floating arrows” than arrows with fixed position.

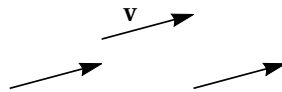

There is a standard way to draw vectors in a coordinate plane. A vector is in **standard position** if it is drawn on an x, y -plane with its initial point at the origin. When a vector is drawn in standard position, we name it by its terminal point (which has two coordinates). This is called the **component form** of the vector. The coordinates of a vector are called the **horizontal** and **vertical components** of the vector.

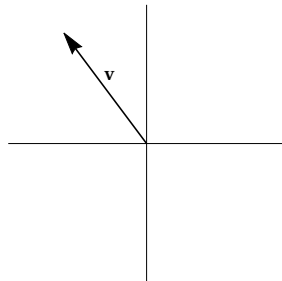

2.3. The coordinate plane

Two vectors drawn in this way are equal if and only if they have the same horizontal component and same vertical component:

$$\langle a, b \rangle = \langle c, d \rangle \quad \text{means } a = c \text{ and } b = d.$$

More generally, the components of any vector drawn anywhere on an x, y -plane can be found by subtracting the initial point from the terminal point (in the same way that an object's displacement can be found by subtracting its initial position from its end position):

EXAMPLE 6

Let \mathbf{v} be a vector which has initial point $(2, -5)$ and terminal point $(-3, -1)$.

- a) Sketch \mathbf{v} on the coordinate plane provided below, in the position indicated by the given information in the problem.

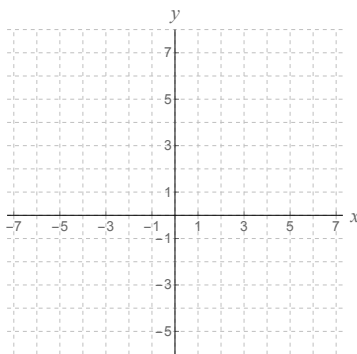

- b) Write \mathbf{v} in component form.
- c) If \mathbf{v} was drawn so that it started at $(5, -1)$, where would \mathbf{v} end?
- d) Sketch \mathbf{v} in standard position.

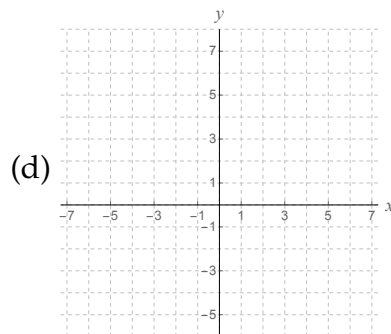
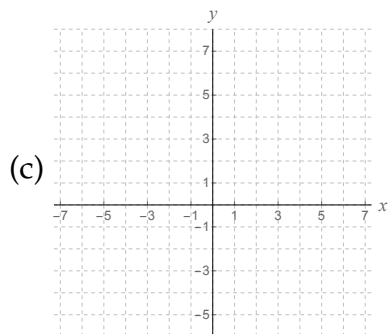

2.4 Vector operations

Addition of vectors

RECALL

Thinking of numbers as linear displacements, we interpreted addition of those numbers as combining two linear displacements that occur in sequence, one after another, i.e.

$$6 + (-3) = \text{six units forward, then three units backwards.}$$

In the same way, by thinking of vectors as representing displacements in a plane that occur in sequence, we can *add* those vectors to obtain a *sum* that represents the total displacement of the object.

EXAMPLE 7

Suppose you first move by $\langle 8, 3 \rangle$ and then move by $\langle 5, -7 \rangle$. What is the combined amount you have moved by?

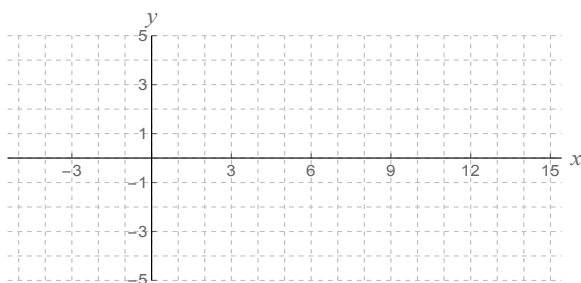

With this example in mind, we add the vectors “coordinate-wise” or “component-wise”, meaning that you add the horizontal components together and the vertical components together.

Subtraction of vectors is similar: given \mathbf{v} and \mathbf{w} , to find $\mathbf{v} - \mathbf{w}$ you subtract coordinate-wise.

Definition 2.3 (Addition and subtraction of vectors) Given vectors $\mathbf{v} = \langle a, b \rangle$ and $\mathbf{w} = \langle c, d \rangle$, the **sum** of \mathbf{v} and \mathbf{w} is the vector

$$\mathbf{v} + \mathbf{w} = \langle a + c, b + d \rangle.$$

Similarly, the **difference** of \mathbf{v} and \mathbf{w} is

$$\mathbf{v} - \mathbf{w} = \langle a - c, b - d \rangle.$$

EXAMPLE 8

Let $\mathbf{v} = \langle 3, -2 \rangle$ and let $\mathbf{w} = \langle 7, 5 \rangle$. Compute the following quantities:

a) $\mathbf{v} + \mathbf{w}$

b) $\mathbf{w} - \mathbf{v}$

c) $\mathbf{w} + \mathbf{w}$

Solution: $\mathbf{w} + \mathbf{w} = \langle 7, 5 \rangle + \langle 7, 5 \rangle = \langle 7 + 7, 5 + 5 \rangle = \boxed{\langle 14, 10 \rangle}$.

Similar to Example 7, we think of the addition of two vectors geometrically using what is called “head-to-tail” or “parallelogram” addition, where we interpret $\mathbf{v} + \mathbf{w}$ as “motion by \mathbf{v} , then motion by \mathbf{w} ” (or vice versa):

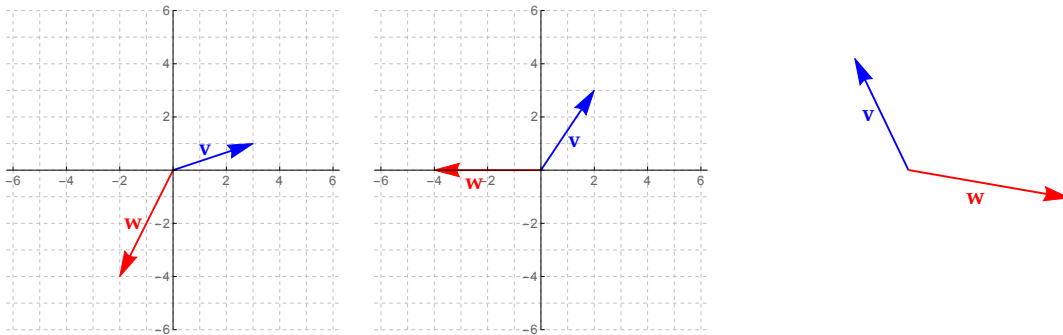

Scalar multiplication of vectors

Definition 2.4 (Scalar multiplication of vectors) Given a vector $\mathbf{v} = \langle a, b \rangle$ and a scalar c , the **(scalar) product** of $c\mathbf{v}$ is the vector

$$c\mathbf{v} = \langle ca, cb \rangle.$$

The vector $-\mathbf{v} = \langle -a, -b \rangle$ is called the **opposite** or **additive inverse** of \mathbf{v} ; it has the same magnitude as \mathbf{v} but points in the opposite direction.

The vector $\mathbf{0} = \vec{0} = \langle 0, 0 \rangle$ is called the **zero vector**. For any vector \mathbf{v} , $0\mathbf{v} = \mathbf{0}$ and $\mathbf{v} + (-\mathbf{v}) = \mathbf{0}$.

Addition and scalar multiplication of vectors are commutative, associative and distributive. That means that the usual rules of arithmetic hold:

$$\begin{array}{ll}
 \mathbf{v} + \mathbf{w} = \mathbf{w} + \mathbf{v} & \mathbf{v} + \mathbf{0} = \mathbf{v} \\
 \mathbf{u} + (\mathbf{v} + \mathbf{w}) = (\mathbf{u} + \mathbf{v}) + \mathbf{w} & \mathbf{v} + (-\mathbf{v}) = \mathbf{0} \\
 (cd)\mathbf{v} = c(d\mathbf{v}) & 0\mathbf{v} = \mathbf{0} \\
 c(\mathbf{v} + \mathbf{w}) = c\mathbf{v} + c\mathbf{w} & 1\mathbf{v} = \mathbf{v} \\
 (c + d)\mathbf{v} = c\mathbf{v} + d\mathbf{v} &
 \end{array}$$

EXAMPLE 9

Let $\mathbf{u} = \langle 0, -3 \rangle$, let $\mathbf{v} = \langle 3, -1 \rangle$ and let $\mathbf{w} = \langle 7, 2 \rangle$. Compute the following quantities:

a) $4\mathbf{w}$

b) $2\mathbf{u} + \mathbf{w}$

Solution: $2\mathbf{u} + \mathbf{w} = 2\langle 0, -3 \rangle + \langle 7, 2 \rangle = \langle 0, -6 \rangle + \langle 7, 2 \rangle = \langle 0 + 7, -6 + 2 \rangle = \langle 7, -4 \rangle$.

c) $5(\mathbf{u} + \mathbf{w}) - \mathbf{v}$

d) $-3\mathbf{u} - 4\mathbf{v}$

Solution: $-3\mathbf{u} - 4\mathbf{v} = -3\langle 0, -3 \rangle - 4\langle 3, -1 \rangle = \langle 0, 9 \rangle - \langle 12, -4 \rangle = \langle 0 - 12, 9 - (-4) \rangle = \langle -12, 13 \rangle$.

e) $0\mathbf{v} - 2\mathbf{u}$

f) $\mathbf{0} + 3\mathbf{v}$

Solution: $\mathbf{0} + 3\mathbf{v} = 3\mathbf{v} = 3\langle 3, -1 \rangle = \langle 9, -3 \rangle$.

We think of scalar multiplication as “shrinking” or “stretching” the vector. Examples are on the next page:

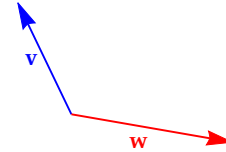
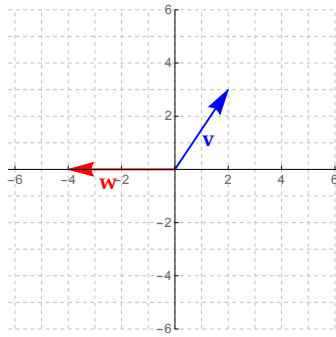
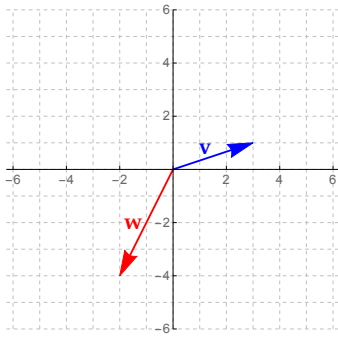

EXAMPLE 10

Suppose \mathbf{a} and \mathbf{b} are the vectors shown below. Sketch the vectors $\frac{3}{4}\mathbf{a}$, $\mathbf{a} + 2\mathbf{b}$ and $\mathbf{b} - 3\mathbf{a}$ on this picture, being sure to label which vector is which:

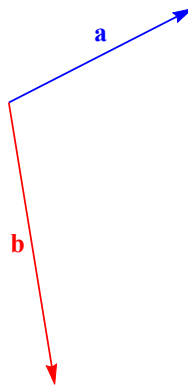

Dot product

Definition 2.5 Given two vectors $\mathbf{v} = \langle a, b \rangle$ and $\mathbf{w} = \langle c, d \rangle$, the **dot product** of \mathbf{v} and \mathbf{w} is

$$\mathbf{v} \cdot \mathbf{w} = ac + bd.$$

Note that *the dot product of two vectors is a **number**, not a vector.*

EXAMPLE 11

Let $\mathbf{u} = \langle 0, -3 \rangle$, let $\mathbf{v} = \langle 3, -1 \rangle$ and let $\mathbf{w} = \langle 7, 2 \rangle$. Compute each quantity:

a) $\mathbf{u} \cdot \mathbf{v}$

b) $\mathbf{v} \cdot \mathbf{w}$

Solution: $\mathbf{v} \cdot \mathbf{w} = \langle 3, -1 \rangle \cdot \langle 7, 2 \rangle = 3(7) + (-1)(2) = 21 - 2 = \boxed{19}$.

c) $\mathbf{v} \cdot \mathbf{v}$

Solution: $\mathbf{v} \cdot \mathbf{v} = \langle 3, -1 \rangle \cdot \langle 3, -1 \rangle = 3^2 + (-1)^2 = \boxed{10}$.

d) $2\mathbf{u} \cdot \mathbf{w}$

e) $\mathbf{v} \cdot (\mathbf{v} - \mathbf{w})$

Usual rules of arithmetic hold for dot product:

$$\begin{array}{ll} \mathbf{v} \cdot \mathbf{w} = \mathbf{w} \cdot \mathbf{v} & \mathbf{v} \cdot \mathbf{0} = 0 \\ \mathbf{u} \cdot (\mathbf{v} + \mathbf{w}) = \mathbf{u} \cdot \mathbf{v} + \mathbf{u} \cdot \mathbf{w} & (c\mathbf{v}) \cdot \mathbf{w} = \mathbf{v} \cdot c\mathbf{w} = c(\mathbf{v} \cdot \mathbf{w}) \\ (\mathbf{u} + \mathbf{v}) \cdot \mathbf{w} = \mathbf{u} \cdot \mathbf{w} + \mathbf{v} \cdot \mathbf{w} & \end{array}$$

WARNING: You can't do $\mathbf{u} \cdot \mathbf{v} \cdot \mathbf{w}$:

Why would anyone care about dot product?

We'll see other reasons later, but in physics, dot products are used to compute **work**, which is the amount of energy converted from one form to another:

Theorem 2.6 (Work formula) *If an object is displaced by vector \mathbf{d} using force \mathbf{F} , then the work W done by this motion is*

$$W = \mathbf{F} \cdot \mathbf{d}.$$

Units: The units of work are the units of force times the units of distance. For instance, if the force is measured in Newtons (N) and the displacement is in meters, then the work is measured in Joules (J), where a Joule is one Newton times one meter.

EXAMPLE 12

A cart on a track is moved from position $(0, 10)$ to $(35, 64)$ (the position is measured in feet) via a force $\mathbf{F} = \langle 150, 70 \rangle$ lbs. Compute the work done by moving the cart in this fashion.

2.5 Angles

In the previous sections, we talked about numbers (and vectors) as measures of *linear displacement*, representing motion in a straight line. But there is a second kind of motion: *rotation* (or *revolution*). Here, your displacement isn't measured by how far you go in a line... it is measured by how far you go _____ .

What is an angle?

An **angle** is an *amount of angular displacement*, i.e. an *amount of rotation*. We draw angles by sketching two (half-)lines, both starting at the same point, and thinking of the angle as rotating from one line to the second (possibly with some number of full rotations before we stop).

We often denote angles by capital letters (A, B, C, M, N, \dots) or lowercase Greek letters ($\alpha, \beta, \gamma, \delta, \pi, \phi, \psi, \theta$).

Some Greek letters:

α	alpha	δ	delta	ϕ or φ	phi
β	beta	θ	theta	ψ	psi
γ	gamma	ω	omega	π	pi

Degree measure

The **measure** of an angle is how much it rotates; the more an angle rotates, the greater its measure. We need to choose a unit for this measurement. The oldest unit of measurement for angles comes from the ancient Babylonians: they estimated that there were 360 days in a year, so they set up their unit of measurement so that an angle which measures "all the way around" once is 360 units. That unit is called a **degree** and is denoted with a $^\circ$.

WARNING: Never, ever, ever leave the $^\circ$ off an angle if you are measuring it in degrees. Units are always required, and $^\circ$ is a type of unit!

Since one complete revolution is 360° , one-half of a revolution measures _____. This is the number of degrees in a straight line (see the picture below at left).



Furthermore, a right angle, which is _____ of a revolution, measures _____. This is the angle made when perpendicular lines meet (see the picture above at right).

We physically measure the number of degrees in an angle using a **protractor**.

Conversion between revolutions and degrees

EXAMPLE 13

- a) Convert $\frac{8}{5}$ revolutions to degrees.
- b) How many revolutions are there in 2584° ?

Angle addition

RECALL

Thinking of numbers as linear displacements, we interpreted addition of those numbers as combining two linear displacements that occur in sequence, one after another, i.e.

$$8 + 7 = \text{eight units forward, then another seven units forward}$$

$$6 - 2 = \text{six units forward, then two units backward}$$

Angle addition works the same way, but instead of forward and backward, you think of positive angle measures as being _____ and negative angle measures as being _____. As an example,

$$100^\circ + 25^\circ =$$

$$150^\circ - 80^\circ =$$

This means that if the terminal side of angle α is the same as the initial side of angle β , then the measures of the angles add:



EXAMPLE 14

Determine the measure of each angle in this picture:

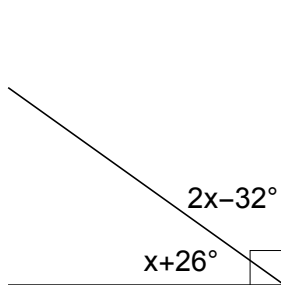

Two angles whose measures add to 90° (like the two angles in Example 14) are called **complementary**.

EXAMPLE 15

Determine the measure of each angle in this picture:

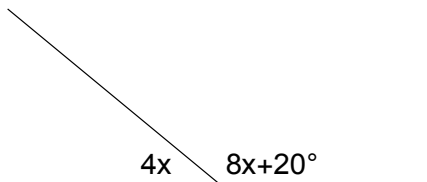

Two angles whose measures sum to 180° (like in Example 15) are called **supplementary**.

Important: we have seen here that angle measurement is **oriented**; that is, we think of the measure as starting on one side of the angle (the **initial side**) and ending on the other side (the **terminal side**). If the angle is measured counterclockwise, then the measure is positive; if the angle is measured clockwise, then the measure is negative.

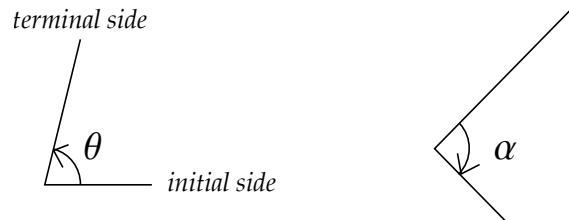

Theorem 2.7 *If an angle measures θ when measured counterclockwise, then it measures $-\theta$ when measured clockwise.*

Absent any other indication: always assume all angles are measured **counterclockwise** and that the angle under consideration is the **smaller** of the two options. To indicate an angle which is measured clockwise or an angle which is “large”, draw an arrow inside the angle:



Angular velocity

RECALL

Linear velocity v is the rate of change of linear displacement, given by the following formula:

$$\text{linear velocity} = \frac{\text{linear displacement}}{\text{elapsed time}} \quad \text{i.e.} \quad v =$$

In a similar way, we can define **angular velocity** ω to be the rate of change of angular displacement, given by the following formula:





$$\text{angular velocity} = \frac{\text{angular displacement}}{\text{elapsed time}} \quad \text{i.e.} \quad \omega =$$

EXAMPLE 15

- a) If a wheel rotates 620° in 18 seconds, what is its angular velocity (in degrees per second)?
- b) If a record is spinning at 45 rpm (revolutions per minute), how long does it take to rotate through a 30° angle?

Classification of angles

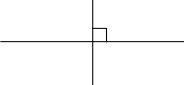
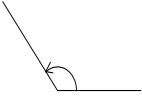
We categorize angles based on their measure:

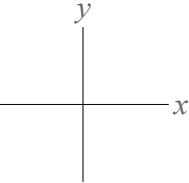
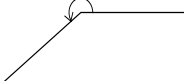
TYPE OF ANGLE	DESCRIPTION IN ENGLISH	CONDITION ON MEASURE	PICTURE
Zero angle	Zero measure (doesn't open)	$\theta = 0^\circ$	
Acute angle	Positive, but less than a right angle	$0^\circ < \theta < 90^\circ$	
Right angle	Formed by \perp lines	$\theta = 90^\circ$	
Obtuse angle	More than a right angle, but less than a straight line	$90^\circ < \theta < 180^\circ$	
Straight angle	Formed by a straight line	$\theta = 180^\circ$	
Quadrantal angle	Multiple of 90°	$\theta = 0^\circ, \pm 90^\circ, \pm 180^\circ, \pm 270^\circ, \pm 360^\circ \dots$	
Reflex angle	More than a straight line	$\theta > 180^\circ$	

2.6 Solving angle pictures

Vertical angles

When two lines cross, the “opposite” angles formed are called **vertical angles**:

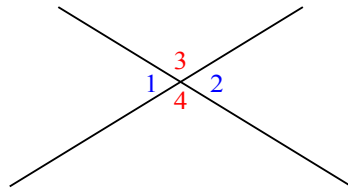

$\angle 1$ and $\angle 2$ are vertical

$\angle 3$ and $\angle 4$ are vertical

Theorem 2.8 *Vertical angles have the same measure.*

EXAMPLE 16

Two angles measuring $5x + 13^\circ$ and $8x - 23^\circ$ are vertical. Draw a picture that represents the setup of this problem, and then determine the value of x .

Parallel lines and transversals

When a third line crosses a pair of parallel lines, the third line is called a **transversal**. In such a picture, eight angles are created; these angles divide into two sets of four where the angles in each set have the same measure:

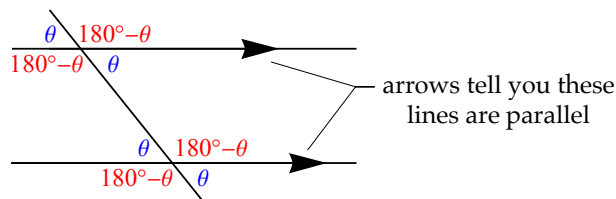

WARNING: In a picture, do not assume lines that “look” parallel are actually parallel, unless told.

EXAMPLE 17

Determine the value of x , assuming that the two lines in the picture that look parallel are actually parallel:

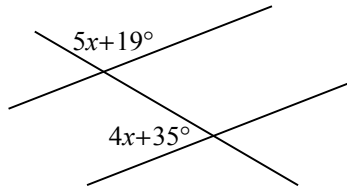

Angles in triangles

Theorem 2.9 *The sum of the measures of the three angles of any triangle is 180° .*

Why is this true?

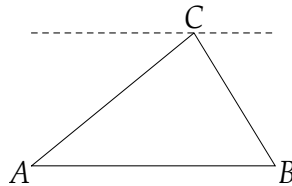

EXAMPLE 18

If two angles of a triangle measure 47° and 78° , what is the measure of the third angle of the triangle?

Definition 2.10 *A triangle is called..*

- ... **scalene** if it has three sides of different lengths;
- ... **isosceles** if it has two or more sides of equal length (i.e. two or more angles of equal measure);
- ... **equilateral** if it has three sides of equal length (i.e. all three angles measure 60°).

Theorem 2.11 (Isosceles Triangle Theorem) *Two sides of a triangle have the same length if and only if the angles opposite those sides have the same measure.*

EXAMPLE 19

Compute the measures of all three angles of $\triangle ABC$, and then, compute y :

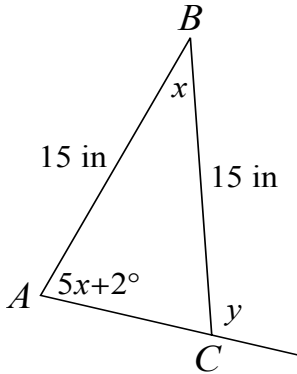

2.7 Pythagorean Theorem

Definition 2.12 A triangle is called..
... **right** if one of its angles is a right angle;
... **acute** if it has three acute angles;
... **obtuse** if one of its angles is obtuse.

EXAMPLE 20

A right triangle has a 41° angle in it. Find the measures of all three angles of the triangle.

In a right triangle, the **hypotenuse** is the longest side (which must be the side opposite the right angle). The other two sides are called **legs**.

Right triangles are special because of the following property, which is the fact on which all of trigonometry is based:

Theorem 2.13 (Pythagorean Theorem) Suppose ABC is a right triangle, where two legs have length a and b and the hypotenuse has length c . Then

$$a^2 + b^2 = c^2.$$

PROOF Start with the right triangle pictured below:

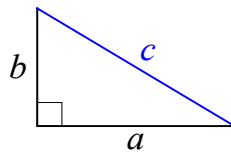

Next, make a large square by taking four copies of this triangle and arranging them as pictured below:

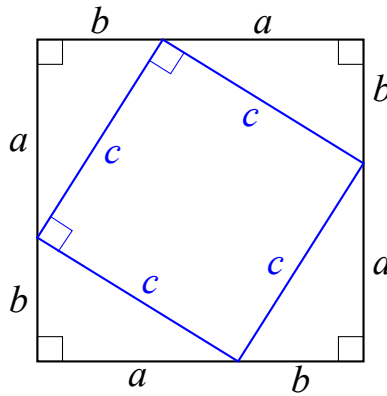

We will prove the Pythagorean Theorem by computing the area of this square pictured above in two different ways:

Method 1:
length \times width

Method 2:
area of middle square + area of triangles

EXAMPLE 20

If the two legs of a right triangle have lengths 15 and 13, what is the length of the hypotenuse?

EXAMPLE 21

Determine the value of x :

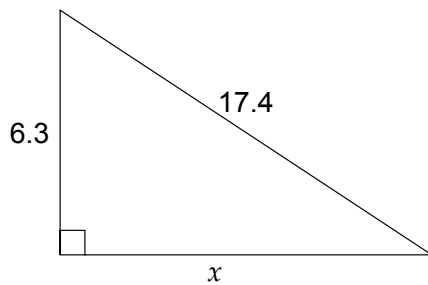

Solution:

$$\begin{aligned} a^2 + b^2 &= c^2 \\ 6.3^2 + x^2 &= 17.4^2 \\ 39.69 + x^2 &= 302.76 \\ x^2 &= 263.07 \\ x &= \sqrt{263.07} = \boxed{16.22}. \end{aligned}$$

WARNING: The Pythagorean Theorem does **not** hold for triangles that are not right triangles.

In fact, the Pythagorean Theorem can be used as a test to determine if the triangle is a right triangle, an obtuse triangle, or an acute triangle:

Theorem 2.14 Suppose ABC is any triangle with side lengths a , b and c , where c is the length of the longest side.

- If $c^2 > a^2 + b^2$, then the triangle is obtuse ($\angle C > 90^\circ$).
- If $c^2 = a^2 + b^2$, then the triangle is right ($\angle C = 90^\circ$).
- If $c^2 < a^2 + b^2$, then the triangle is acute ($\angle C < 90^\circ$).

EXAMPLE 22

If the three side lengths of a triangle are 14m, 22m and 30m, determine whether the triangle is obtuse, right or acute.

Magnitude of a vector

RECALL

The two important attributes of a vector are its _____ (a.k.a. its size) and its _____ .

We can use the Pythagorean Theorem to determine the magnitude of a vector $\mathbf{v} = \langle a, b \rangle$. We denote the magnitude of vector \mathbf{v} by $|\mathbf{v}|$ and compute it as follows:

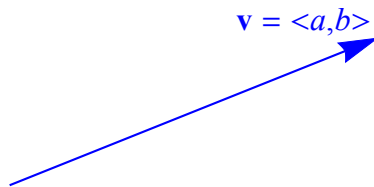

Theorem 2.15 (Magnitude formula) *The magnitude of vector $\mathbf{v} = \langle a, b \rangle$ is*

$$|\mathbf{v}| = \sqrt{a^2 + b^2}.$$

EXAMPLE 23

Compute the magnitude of $\mathbf{v} = \langle -2, 7 \rangle$ (in other words, compute $|\mathbf{v}|$). Explain (using a picture) what this computation means.

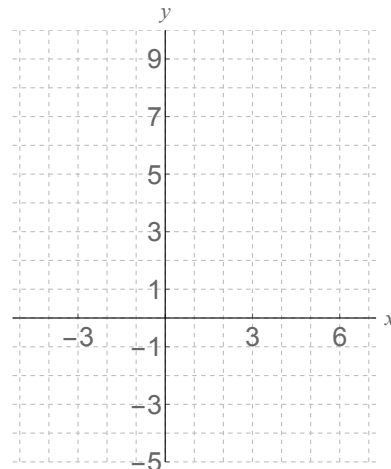

EXAMPLE 24

Compute the magnitude of a force given by vector $\mathbf{F} = \langle 31.25, 16.1 \rangle$ Newtons.

Solution: $|\mathbf{F}| = \sqrt{31.25^2 + 16.1^2} = \sqrt{976.56 + 259.21} = \sqrt{1235.77} = \boxed{35.1536 \text{ N}}$.

Multiplying a vector by a scalar changes its magnitude in the way you might expect:

Theorem 2.16 *Let \mathbf{v} be a vector and c be a scalar. Then*

$$|c\mathbf{v}| = |c| |\mathbf{v}|.$$

EXAMPLE 25

If $|\mathbf{v}| = 12$, what is $|5\mathbf{v}|$? What about $|\frac{1}{4}\mathbf{v}|$?

WARNING: In general, $|\mathbf{v} + \mathbf{w}| \neq |\mathbf{v}| + |\mathbf{w}|$.

For example, if $\mathbf{v} = \langle 3, 0 \rangle$ and $\mathbf{w} = \langle 0, 4 \rangle$, then

$$|\mathbf{v}| + |\mathbf{w}| = \sqrt{3^2 + 0^2} + \sqrt{0^2 + 4^2} = \sqrt{9} + \sqrt{16} = 3 + 4 = \boxed{7}$$

but

$$|\mathbf{v} + \mathbf{w}| = |\langle 3, 4 \rangle| = \sqrt{3^2 + 4^2} = \sqrt{9 + 16} = \sqrt{25} = \boxed{5}.$$

2.8 Standard position of an angle

To draw an angle in **standard position** means to draw it on an xy -plane so that its vertex is at $(0, 0)$ and its initial side is on the positive x -axis.

EXAMPLE 25

Draw each of these angles in standard position:

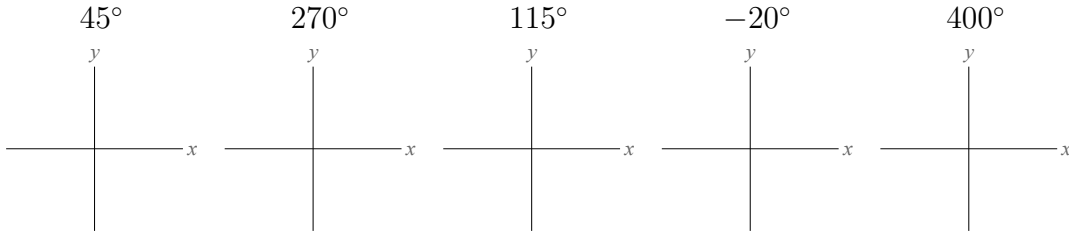

EXAMPLE 26

Estimate the measure of each of these angles (in degrees):

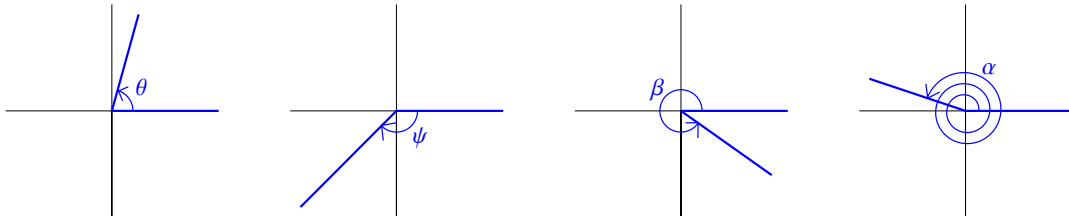

How accurate should you be when drawing an angle in standard position or estimating angle measure?

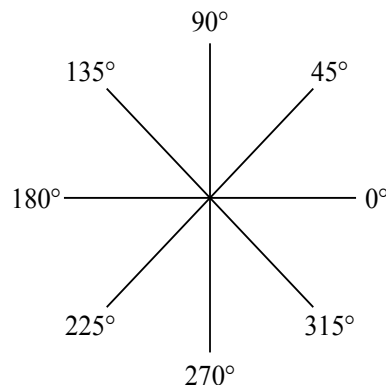

Angle addition in standard position

EXAMPLE 27

- a) Suppose $(2, 5)$ is on the terminal side of θ (when it is drawn in standard position). Estimate the coordinates of a point on the terminal side of 2θ .

- b) Suppose $(-4, 5)$ is on the terminal side of θ (when it is drawn in standard position). Estimate the coordinates of a point on the terminal side of $\theta + 120^\circ$.

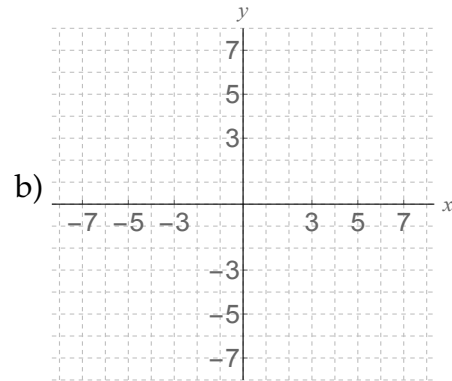
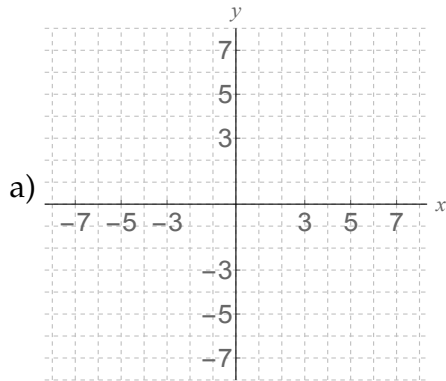

- c) Suppose $(-2, -7)$ is on the terminal side of β (when it is drawn in standard position). Estimate the coordinates of a point on the terminal side of $\beta - 45^\circ$.

- d) Suppose $(3, -7)$ is on the terminal side of ϕ (when it is drawn in standard position). Estimate the coordinates of a point on the terminal side of $3\phi - 90^\circ$.

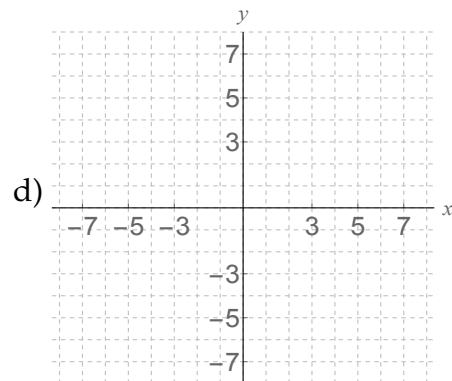
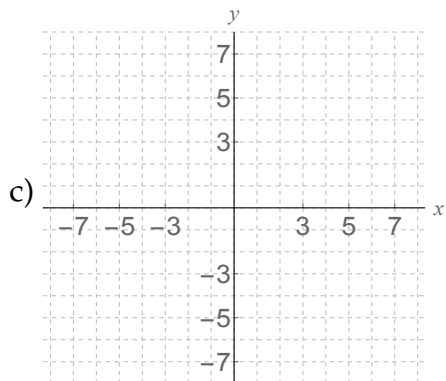

Coterminal angles

EXAMPLE 28

Suppose $(-5, 3)$ is on the terminal side of angle θ (when θ is drawn in standard position). What are the coordinates of a point on $\theta + 360^\circ$? What about $\theta - 720^\circ$?

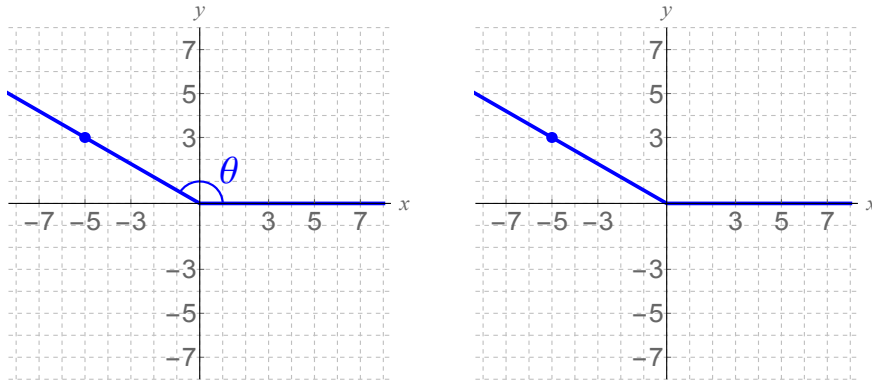

Definition 2.17 Two angles are called **coterminal** if they differ by a multiple of 360° . If angles α and β are coterminal, we write $\alpha \sim \beta$.

EXAMPLE 29

Find three different angles, at least one of which is negative, which are each coterminal with 58° .

EXAMPLE 30

Find an angle between 0° and 360° which is coterminal with 2057° .

Theorem 2.18 Suppose (x, y) is on the terminal side of angle α when drawn in standard position.

If $\alpha \sim \beta$ (i.e. α and β are coterminal), then (x, y) is also on the terminal side of β .

In particular, (x, y) is also on the terminal side of $\alpha \pm 360^\circ$.

Similarities and differences between coterminal angles

Suppose two angles are coterminal, but not equal.

Example: $30^\circ \sim 750^\circ$, but $30^\circ \neq 750^\circ$.

We can think of these angles as being the same if...

We need to think of these angles as being different if...

Reflections and symmetric angles

Definition 2.19 Two angles are called **symmetric** if, when you draw them both in standard position, you can get from the terminal side of one to the terminal side of the other by reflecting across the x -axis and/or y -axis.

Put another way, two symmetric angles either have the same slope, or their slopes are opposites.

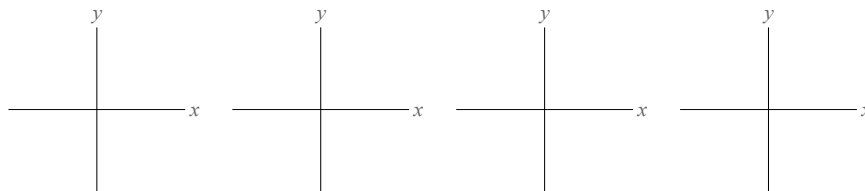

EXAMPLE 31

Find (the measure of) an angle in the second quadrant which is symmetric with 24° .

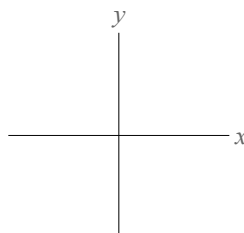

EXAMPLE 32

Find four angles between 0° and 360° which are symmetric with 160° .

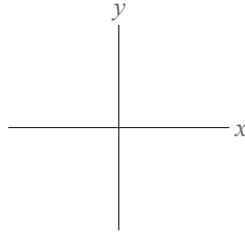

EXAMPLE 33

Suppose $0^\circ < \theta < 90^\circ$ and that (x, y) is a point on the terminal side of θ . What are the coordinates of a point in Quadrant IV, at an angle symmetric with θ ?

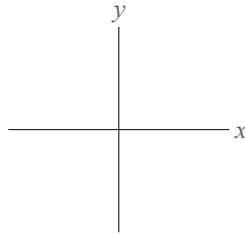

QUESTION

In general, what angles are symmetric with θ ?

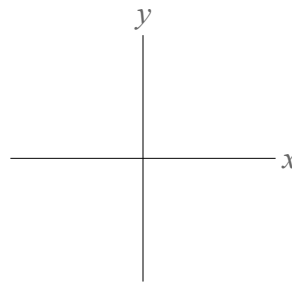
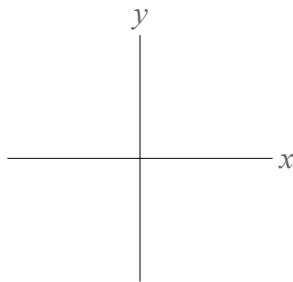

Theorem 2.20 (Angle symmetries I) Let θ be an angle, and let (x, y) be the coordinates of the point on the terminal side of angle θ . Then, the four different angles symmetric with θ , and the coordinates of a point on the terminal side of those angles are:

θ	\longleftrightarrow	(x, y)	
$180^\circ - \theta$	\longleftrightarrow	$(-x, y)$	(reflect θ across the y-axis)
$\theta \pm 180^\circ$	\longleftrightarrow	$(-x, -y)$	(reflect θ across both axes / opposite to θ)
$360^\circ - \theta$	\longleftrightarrow	$(x, -y)$	(reflect θ across the x-axis).

2.8. Standard position of an angle



EXAMPLE 34

Suppose $(-12, 7)$ is on the terminal side of θ , when θ is drawn in standard position.

- a) What are the coordinates of a point on the terminal side of $180^\circ - \theta$?

- b) What quadrant is $\theta + 180^\circ$ in?

- c) In terms of θ , what angle has $(-12, -7)$ on its terminal side?

EXAMPLE 35

Suppose (x, y) is on the terminal side of angle θ in standard position. For each given angle, give (in terms of x and y) the coordinates of a point on the terminal side of that angle:

- a) $180^\circ - \theta$

- b) $720^\circ - \theta$

- c) $8 \cdot 360^\circ + \theta$

- d) $-\theta$

- e) $540^\circ - \theta$

Reference angles

Every angle is symmetric with exactly one angle in the first quadrant.

Definition 2.21 Given angle θ , the **reference angle** of θ is the angle $\hat{\theta}$ (this is pronounced “theta hat”) in the first quadrant (i.e. $0^\circ \leq \hat{\theta} \leq 90^\circ$) which is symmetric with θ .

EXAMPLE 36

Determine the reference angle of each angle:

- a) 193°
- b) 854°
- c) -320°

Another type of symmetry

EXAMPLE 37

Suppose $(5, 3)$ is on the terminal side of θ when θ is drawn in standard position. Find the coordinates of a point on the terminal side of $90^\circ - \theta$.

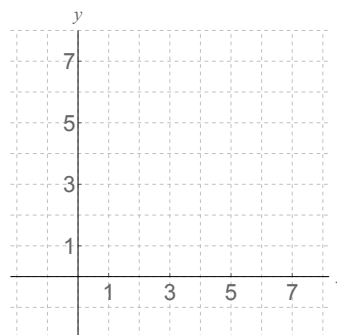
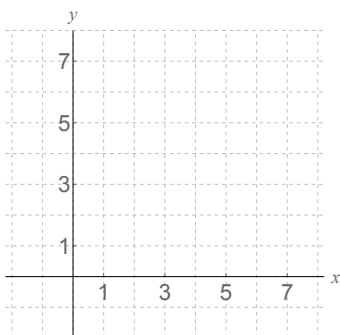

Theorem 2.22 (Angle symmetries II) Suppose (x, y) is on the terminal side of angle θ when drawn in standard position. Then:

- (y, x) is on the terminal side of $90^\circ - \theta$, and
- the angle $90^\circ - \theta$ is obtained from θ by reflecting the terminal side across the diagonal line $y = x$.

2.9 Radian measure

Preliminary material needed to understand radians

The unit circle

The **unit circle** is a circle of radius 1 centered at $(0, 0)$. In other words, the unit circle is the set of points (x, y) such that the distance from (x, y) to $(0, 0)$ is 1. Here is a picture of the unit circle:

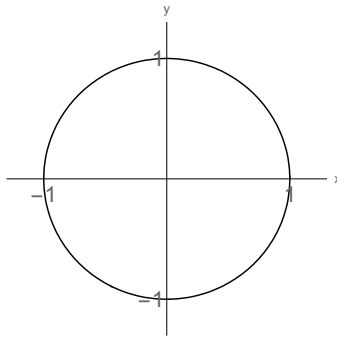

Question: What is the equation of the unit circle?

Answer: From the Pythagorean Theorem, we have

Theorem 2.23 Every point (x, y) on the unit circle satisfies $x^2 + y^2 = 1$.

EXAMPLE 38

Find all y such that the point $\left(\frac{2}{3}, y\right)$ is on the unit circle.

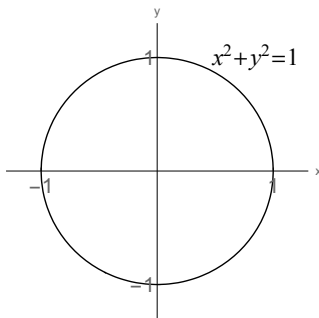

EXAMPLE 39

Find the point where the terminal side of a 135° angle, drawn in standard position, intersects the unit circle.

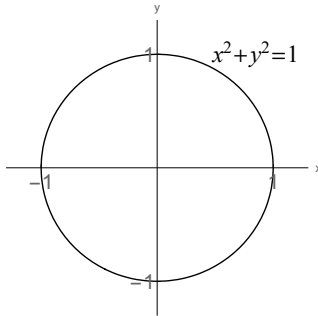
**Length of a curve; circumference**

The **length** of a line segment in the xy -plane is the straight line distance between its endpoints.

To define the length of a *curve* (theoretically), imagine the curve is made of string. Take the string and pull it until it is taut. The length of the taut string is the length of the curve.

In general, it is very, very hard to find the exact length of curves, and most curves do not have lengths which are nice (rational) numbers like 3 or $\frac{8}{3}$ or $\frac{127}{37}$ or 175.6. There are formulas for lengths of curves you learn in calculus, but even these are hard to implement in practice.

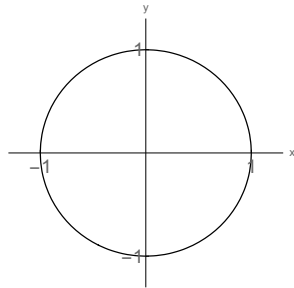

In particular, the circumference (i.e. length of one revolution) of the unit circle is not a whole number (it is between 6 and 7). It is not a terminating decimal (although it is about 6.28), or a fraction whose numerator and denominator are whole numbers (although it is about $\frac{44}{7}$). Because this number is useful, we give it a name:

Definition 2.24 The number τ (pronounced “tau”) is the circumference of the unit circle, i.e. the circumference of any circle of radius 1 unit.

Math would be easier if formulas were evaluated in terms of τ . However, English mathematicians in the 1700s decided to work with exactly half of τ , which is the distance around half of the unit circle. They assigned that number its symbol, which we still use today:

Definition 2.25 The number π (pronounced “pi”) is $\frac{1}{2}\tau$, i.e. π is half of the circumference of any circle of radius 1 unit.

$\pi \approx 3.14159$ and $\pi \approx \frac{22}{7}$, but most calculators have a π button you should use.

Theorem 2.26 (Circumference formulas)

The circumference of the unit circle is 2π .

The circumference of a circle of radius r units is $C = 2\pi r$.

EXAMPLE 40

Compute the circumference of a circle whose diameter is 18 inches.

Definition of a radian

A radian is an extremely useful unit of measurement for angle measure. The definition is a little abstract:

Definition 2.27 A **radian** is a unit of angle measure such that the radian measure of any angle equals the length of the arc on the unit circle subtended by the angle, when drawn in standard position.

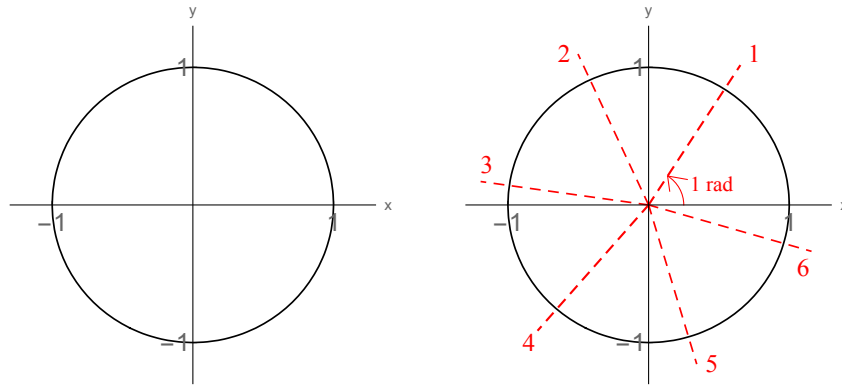

Converting between degrees and radians

Based on the definition of a radian, we know

one complete revolution (360°) is equal to _____ radians,

so a straight angle (180°) measures _____ radians,

and a right angle (90°) measures _____ radians.

This gives us formulas for converting between degrees and radians:

Theorem 2.28 (Converting between degrees and radians)

1. Multiply an angle measure by $\frac{\pi}{180^\circ}$ to convert degrees to radians.
2. Multiply an angle measure by $\frac{180^\circ}{\pi}$ to convert radians to degrees.

Summary of conversions between units of angle measure

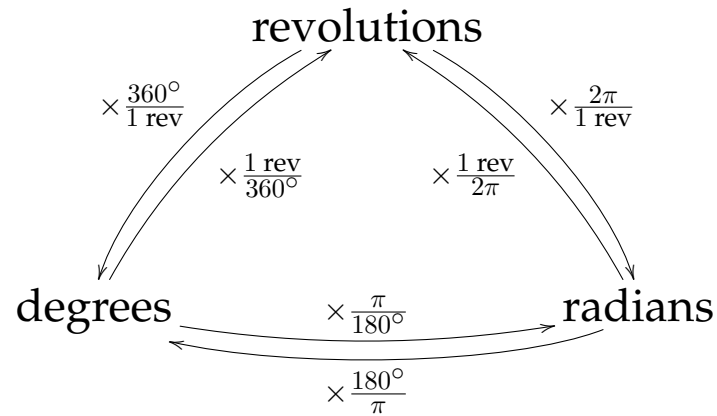

EXAMPLE 41

1. Convert 124° to radians.

Solution: $124^\circ \cdot \frac{\pi}{180^\circ} = 124^\circ \cdot \frac{3.14159}{180^\circ} = \boxed{2.164}$. **Q: Why no units?**

2. Convert -240° to radians.

3. Convert 4.25 radians to degrees.

Solution: $4.25 \cdot \frac{180^\circ}{\pi} = \boxed{243.507^\circ}$.

4. Convert $\frac{17}{10}\pi$ radians to degrees.

5. Convert 3.75 revolutions to degrees and radians.

Special angles in radians

There are certain angles (in radians) that you should just “know” how many degrees they correspond to:

$\pi = 180^\circ$	$\frac{\pi}{2} = 90^\circ$	$\frac{\pi}{3} = 60^\circ$	$\frac{\pi}{4} = 45^\circ$	$\frac{\pi}{6} = 30^\circ$
-------------------	----------------------------	----------------------------	----------------------------	----------------------------

EXAMPLE 42 (NO CALCULATOR)

Convert the following angles to degrees, and draw each in standard position.

$$\frac{3\pi}{2} =$$

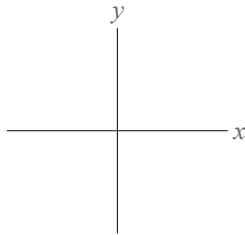

$$\frac{-3\pi}{4} =$$

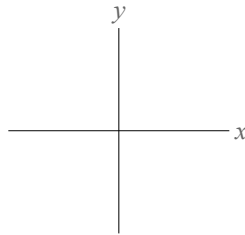

$$\frac{5\pi}{6} =$$

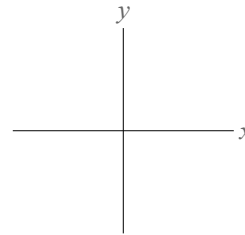

A useful diagram showing the special angles in radians

IF IN LOWEST TERMS:

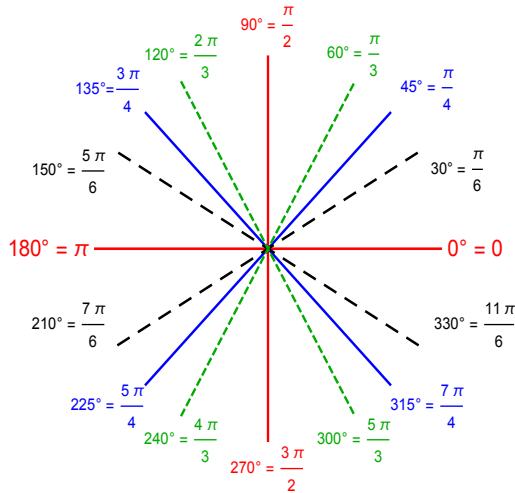

(whole #) π \longleftrightarrow

$\frac{\text{(odd \#)} \pi}{2}$ \longleftrightarrow

$\frac{\text{(whole \#)} \pi}{4}$ \longleftrightarrow

$\frac{\text{(whole \#)} \pi}{3}$ \longleftrightarrow

$\frac{\text{(whole \#)} \pi}{6}$ \longleftrightarrow

Theorem 2.29 If θ is in radians, expressed as a fraction $\frac{a\pi}{b}$ where $\frac{a}{b}$ is in lowest terms and $b = 2, 3, 4,$ or 6 , then the reference angle of θ is $\frac{\pi}{b}$.

IMPORTANT: The default unit of measurement for angles is radians! So unless you write a $^\circ$, the measure of an angle is understood to be in radians. So an angle measuring “90” measures 90 radians, not 90° .

2.10 Applications of radian measure

Radians are a superior unit of angle measure to degrees. One reason is that radians can be used to convert angle measures to lengths of curves and areas of sectors without any additional work.

Arc length

Take a circle of radius r , and take an arc on that circle subtended by angle θ . Call the length of the arc s .

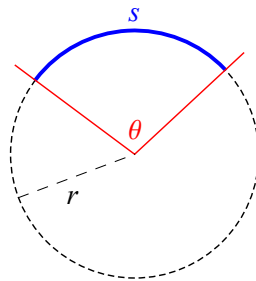

	Angle measure (in radians)	Circumference / arc length
One complete revolution	2π	
Unknown angle	θ	s

We can use this chart to set up a proportion:

Theorem 2.30 (Arc length formula) *The length of an arc is*

$$s = r\theta$$

*where r is the radius of the circle and θ is the angle, **measured in radians**.*

EXAMPLE 42

A circle has radius 3.5 ft. Find the length of the arc intercepted by a central angle of 62° .

Area of a sector

A **sector** is the mathematical name for a shape that looks like a pizza wedge:

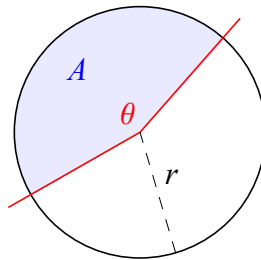

	Angle measure (in radians)	Area
One complete revolution	2π	
Unknown angle	θ	A

We can use this chart to set up a proportion:

$$\frac{2\pi}{\theta} = \frac{\pi r^2}{A}$$

Cross-multiply: $2\pi A = \pi r^2 \theta$

Divide by 2π : $A = \frac{\pi r^2 \theta}{2\pi} = \frac{1}{2} r^2 \theta.$

The work on the previous page shows:

Theorem 2.31 (Sector area formula) *The area of a circular sector is*

$$A = \frac{1}{2} r^2 \theta$$

where r is the radius of the circle and θ is the angle, **measured in radians**.

EXAMPLE 43

A pizza has radius 7 inches. If a slice of pizza has an angle of $\frac{\pi}{10}$ radians, find the area of the pizza slice.

Solution:

$$r = 7 \text{ in}$$

$$\theta = \frac{\pi}{10} \quad \leftarrow \text{☺ radians}$$

$$A = ?$$

$$A = \frac{1}{2} r^2 \theta = \frac{1}{2} (7 \text{ in})^2 \frac{\pi}{10} = \boxed{7.7 \text{ sq in}}.$$

Converting between angular and linear velocity

Suppose an object is moving along a circular path (think of something spinning around on the edge of a wheel). We want to describe how “fast” the object is moving. We have seen two ways to do this:

- The **linear velocity** v of the object is the rate of change of its linear displacement, i.e. the linear displacement (arc length) traveled divided by the elapsed time:

$$v = \frac{s}{t} = \frac{r\theta}{t}$$

- The **angular velocity (angular speed)** ω (omega) of the object is the rate of change of its angular displacement, i.e. the change in its angle divided by the elapsed time:

$$\omega = \frac{\theta}{t}$$

Theorem 2.32 (Converting between angular and linear velocity) *Suppose that an object is moving along a circular path of radius r .*

If its angular velocity is ω (measured in radians per unit of time) and its linear velocity is v , then

$$v = r\omega \quad \text{and} \quad \omega = \frac{v}{r}.$$

EXAMPLE 44

A lizard sits on the outside of a carousel that has radius 22.75 ft. If the carousel rotates at 3.25 radians per second, how fast is the lizard moving (i.e. what is its linear velocity)?

EXAMPLE 45

The Earth is 93,000,000 miles from the sun. What is the linear velocity of Earth, in miles per hour? (How about miles per second?)

Solution: We are given $r = 93000000$ mi and we know

$$\omega = \frac{1 \text{ rev}}{\text{year}} = \frac{2\pi \text{ rad}}{\text{year}}.$$

Therefore

$$v = r\omega = (93000000 \text{ mi}) \frac{2\pi \text{ rad}}{\text{year}} = 5843362336.8 \frac{\text{mi}}{\text{year}}.$$

Now we have to convert this to the appropriate units:

$$\frac{5843362336.8 \text{ mi}}{\text{year}} \cdot \frac{1 \text{ year}}{365 \text{ days}} \cdot \frac{1 \text{ day}}{24 \text{ hr}} = \boxed{66705 \frac{\text{mi}}{\text{hr}}}.$$

In miles per second, this is

$$66705 \frac{\text{mi}}{\text{hr}} \cdot \frac{1 \text{ hr}}{60 \text{ min}} \cdot \frac{1 \text{ min}}{60 \text{ sec}} = \boxed{18.53 \frac{\text{mi}}{\text{sec}}}.$$

Why do we need to understand this?

By controlling the power supplied to a gear or pulley system, you control the angular velocity of that gear or pulley.

EXAMPLE 46

Two gears are interlocked so that they rotate together (see picture below). One gear has a radius of 4 in, and the other gear has a radius of 1 in.

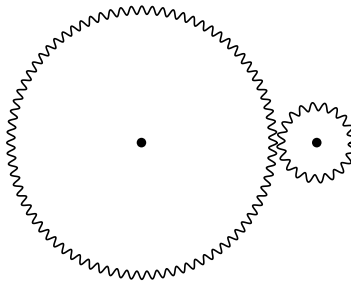

1. If the larger gear is rotated at 400 rpm (revolutions per minute), what is the angular velocity of the smaller gear (in rpm)?
2. If you want the larger gear to rotate at 120 radians per second, what angular velocity (in radians per second) should the smaller gear be rotated at?

EXAMPLE 47

Two pulleys in the figure that will be drawn below have radii of 18 cm and 11 cm, respectively. If the larger pulley rotates 30 times in 12 seconds, find:

1. the angular velocity of each pulley (in radians per second);
2. the linear velocity of each pulley (in cm per second);
3. the distance a point on the belt travels in 10 seconds; and
4. the change in angle a point on the right-hand pulley experiences in 2 seconds.

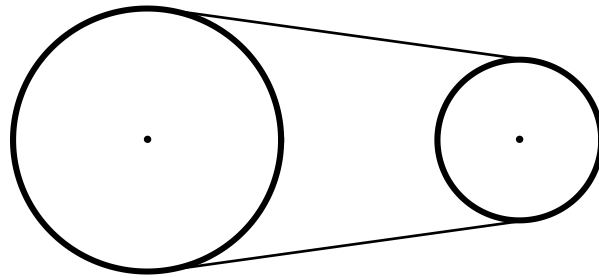

Solution: We are given the larger pulley rotates 30 times in 12 seconds, so the angular velocity of the larger wheel is

$$\omega_{\text{large}} = \frac{30 \text{ rev}}{12 \text{ sec}} = \frac{30 \text{ rev}}{12 \text{ sec}} \cdot \frac{2\pi}{1 \text{ rev}} = \boxed{5\pi \frac{\text{rad}}{\text{sec}}} \approx \boxed{15.7 \frac{\text{rad}}{\text{sec}}}. \quad \leftarrow \#1$$

Next, the linear velocity of the larger pulley is

$$v_{\text{large}} = r_{\text{large}}\omega_{\text{large}} = 18\text{cm} \cdot 5\pi \frac{1}{\text{sec}} = \boxed{90\pi \frac{\text{cm}}{\text{sec}}} \approx \boxed{282.74 \frac{\text{cm}}{\text{sec}}}. \quad \leftarrow \#2$$

The two pulleys must have the same linear velocity, so

$$v_{\text{small}} = v_{\text{large}} = \boxed{90\pi \frac{\text{cm}}{\text{sec}}} \approx \boxed{282.74 \frac{\text{cm}}{\text{sec}}}. \quad \leftarrow \#2$$

Last, the angular velocity of the smaller pulley is

$$\omega_{\text{small}} = \frac{v_{\text{small}}}{r_{\text{small}}} = \frac{90\pi \frac{\text{cm}}{\text{sec}}}{11 \text{ cm}} = \boxed{\frac{90}{11}\pi \frac{\text{rad}}{\text{sec}}} \approx \boxed{25.7 \frac{\text{rad}}{\text{sec}}}. \quad \leftarrow \#1$$

We have found the angular and linear velocities of each pulley, so it remains to answer questions 3 and 4:

$$3. \text{ This is } s = vt = \left(90\pi \frac{\text{cm}}{\text{sec}}\right) (10 \text{ sec}) = \boxed{900\pi \text{ cm}} \approx \boxed{2827.43 \text{ cm}}.$$

$$4. \text{ This is } \theta = \omega_{\text{small}}t = \left(\frac{90}{11}\pi \frac{1}{\text{sec}}\right) (2 \text{ sec}) = \boxed{\frac{180}{11}\pi \text{ rad}} \approx \boxed{51.4 \text{ rad}}.$$

Chapter 3

Sine, cosine and tangent

3.1 Unit circle definitions

RECALL

One of our major course goals is to convert *rotational measurements* into *distance measurements*. To do this, we define **functions** which take as their input a rotational measurement (i.e. an angle) and have as their output a distance measurement (i.e. an x - or y -coordinate or a length).

Unit circle definitions

Definition 3.1 (Unit circle definition of sine, cosine and tangent) Take a number θ . Starting at the point $(1, 0)$, mark off an arc of length θ on the unit circle (go counterclockwise if $\theta > 0$ and clockwise if $\theta < 0$). In other words, mark off an angle of θ radians.

Call the point on the unit circle where the arc ends (x, y) .

Then define the **sine**, **cosine** and **tangent** of θ to be:

$$\sin \theta = \sin(\theta) = y$$

$$\cos \theta = \cos(\theta) = x$$

$$\tan \theta = \tan(\theta) = \frac{y}{x} = \frac{\sin \theta}{\cos \theta} = \text{slope of the terminal side of } \theta$$

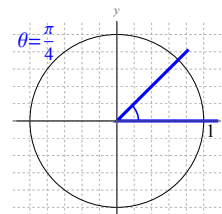
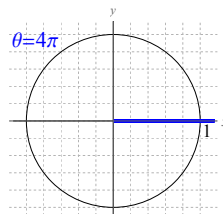
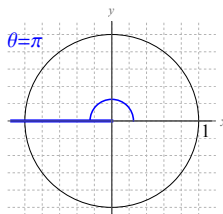
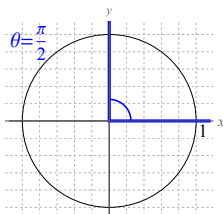

EXAMPLE 1

Compute the following quantities (without a calculator):

a) $\cos \frac{\pi}{2}$

e) $\tan \pi$

b) $\sin 270^\circ$

f) $\cos(-180^\circ)$

c) $\sin 180^\circ$

g) $\tan \frac{3\pi}{2}$

d) $\cos 0$

h) $\sin \frac{-3\pi}{2}$

EXAMPLE 2

Compute the following quantities (without a calculator):

a) $2 \sin 90^\circ$

e) $3 \cos 0 + 2 \tan \pi$

b) $\sin 2 \cdot 90^\circ$

f) $\cos^3 180^\circ$

c) $\tan^2 \pi + \pi$

g) $4 \tan^2 \frac{\pi}{2}$

d) $\cos(\pi + \pi)$

h) $\sin^4 \frac{\pi}{2} \cos 0$

What the trig functions actually mean

These two diagrams explain how the trig functions convert amounts of rotation (the θ) to distance measurements and coordinates (the $\sin \theta$, $\cos \theta$ and $\tan \theta$):

Trig functions as coordinates

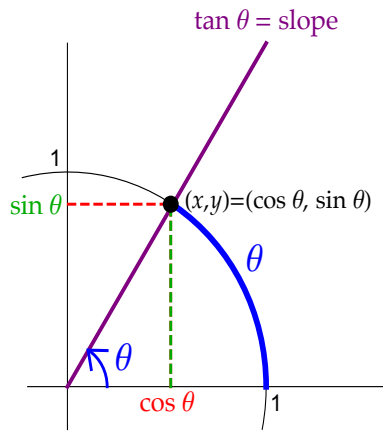

Trig functions as **directed** distances

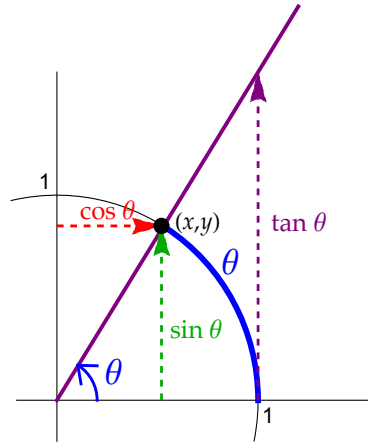

Understanding these pictures is **crucial** to mastering trigonometry. They give us intuition into all kinds of trigonometric problems:

EXAMPLE 3

- a) Estimate the values of $\sin \theta$ and $\cos \theta$ for the angle θ pictured below at left.
- b) Estimate the values of $\cos \alpha$ and $\tan \alpha$ for the angle α pictured below at right.

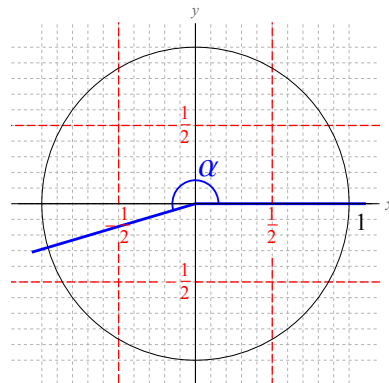
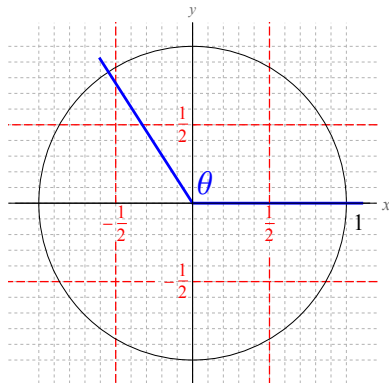

EXAMPLE 4

- a) Estimate $\cos 280^\circ$ by drawing a picture.
- b) Estimate $\sin(-125^\circ)$ by drawing a picture.

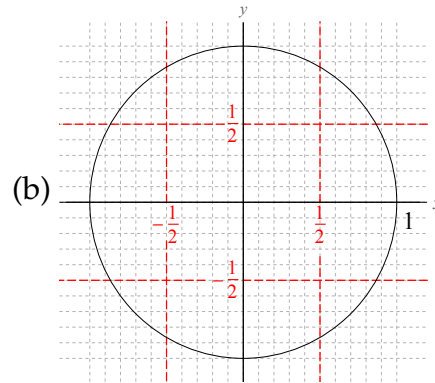
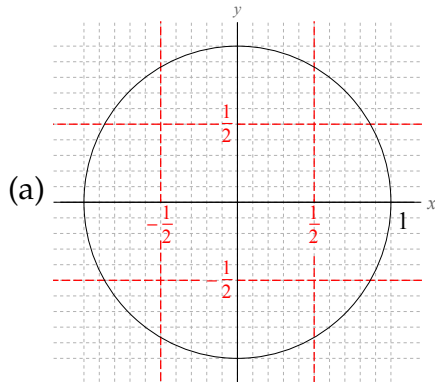

- c) Estimate the degree measure of two different angles θ between 0° and 360° where $\sin \theta = .35$.
- d) Estimate the degree measure of two different angles θ between 0° and 360° where $\cos \theta = -\frac{4}{5}$.

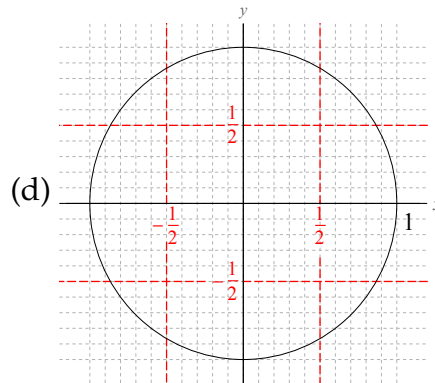
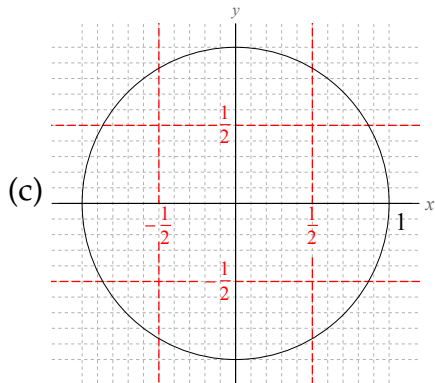

3.1. Unit circle definitions

EXAMPLE 5

On each picture below, give a formula for the distance indicated by the “?” in terms of the angles marked on the picture:

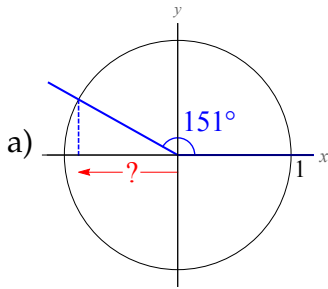

$$? =$$

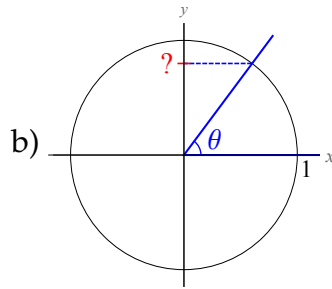

$$? =$$

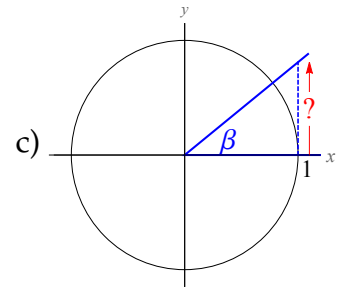

$$? =$$

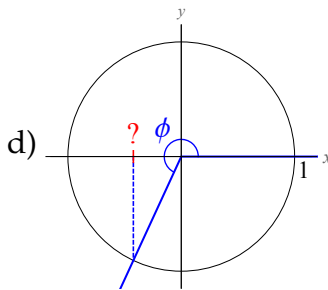

$$? =$$

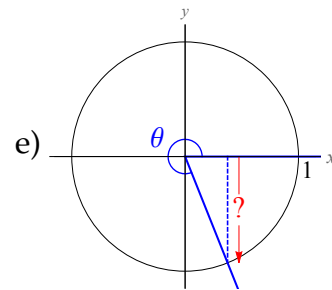

$$? =$$

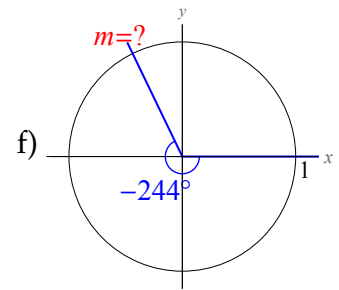

$$? =$$

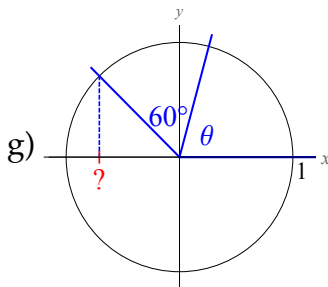

$$? =$$

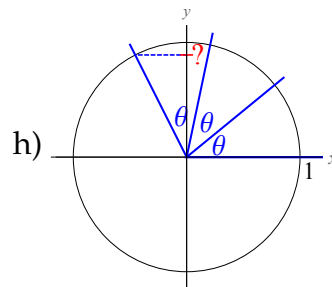

$$? =$$

EXAMPLE 6

For each given quantity, determine which letter A-F best describes that quantity:

- A. between -1 and $-1/2$
 B. between $-1/2$ and 0
 C. exactly zero

- D. between 0 and $1/2$
 E. between $1/2$ and 1
 F. not between -1 and 1

a) $\sin 12^\circ$

e) $\cos(-173^\circ)$

b) $\cos 12^\circ$

f) $\cos 291^\circ$

c) $\sin 193^\circ$

g) $\cos 90^\circ$

d) $\cos(-261^\circ)$

h) $\sin 700^\circ$

QUESTION

Is there a θ where the answer to a question like the previous example would be choice F? For example, is there a θ where $\sin \theta = 1.235$ or $\cos \theta = -4$?

Theorem 3.2 For any number or angle θ ,

$$-1 \leq \sin \theta \leq 1 \quad \text{and} \quad -1 \leq \cos \theta \leq 1.$$

EXAMPLE 7

For each given quantity, determine which letter A-F best describes that quantity (by drawing a picture).

- A. a very negative number
 B. a slightly negative number
 C. zero

- D. a slightly positive number
 E. a very positive number
 F. the quantity doesn't exist

a) $\tan 70^\circ$

c) $\tan 270^\circ$

b) $\tan 170^\circ$

d) $\tan 370^\circ$

QUESTION

Are all the answers A through F possible in the previous question? For example, is there a θ where $\tan \theta = 1.235$ or $\tan \theta = -4$ or $\tan \theta = 2000$?

Theorem 3.3 For any number m , there is an angle θ such that $\tan \theta = m$.

Periodicity

EXAMPLE 8

Consider the angle θ shown below. Sketch $\theta + 360^\circ$ on the right hand picture, and compare the values of the trig functions of θ to the trig functions of $(\theta + 360^\circ)$:

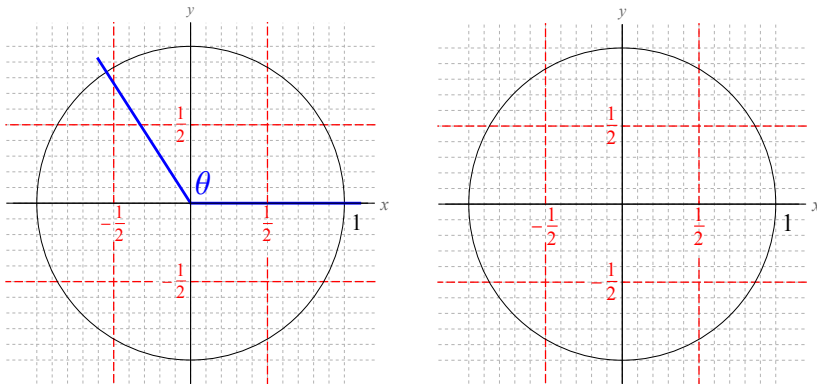

Theorem 3.4 (Periodicity) Coterminal angles have the same trig functions, i.e.

$$\text{if } \alpha \sim \beta, \text{ then } \begin{cases} \sin \alpha = \sin \beta \\ \cos \alpha = \cos \beta \\ \tan \alpha = \tan \beta \end{cases}$$

In particular, this means

$$\sin(\theta \pm 360^\circ) = \sin \theta \quad \cos(\theta \pm 360^\circ) = \cos \theta \quad \tan(\theta \pm 360^\circ) = \tan \theta.$$

and in radians, this is

$$\sin(\theta \pm 2\pi) = \sin \theta \quad \cos(\theta \pm 2\pi) = \cos \theta \quad \tan(\theta \pm 2\pi) = \tan \theta.$$

EXAMPLE 9

If $\cos \theta = \frac{2}{3}$, what is $\cos(\theta - 4\pi)$?

3.2 Angle definitions

Definition 3.5 (Angle definition of sine and cosine) Take an angle θ (in degrees or radians) and draw it in standard position. Choose any point (x, y) on the terminal side of the angle (x and/or y could be positive, negative or zero).

Let r be the distance from (x, y) to the origin, so that $r = \sqrt{x^2 + y^2}$ (r is always positive).

Then define the **sine**, **cosine** and **tangent** of θ to be, respectively,

$$\sin \theta = \frac{y}{r}$$

$$\cos \theta = \frac{x}{r}$$

$$\tan \theta = \frac{y}{x} = \frac{\sin \theta}{\cos \theta} = \text{slope of the terminal side of } \theta$$

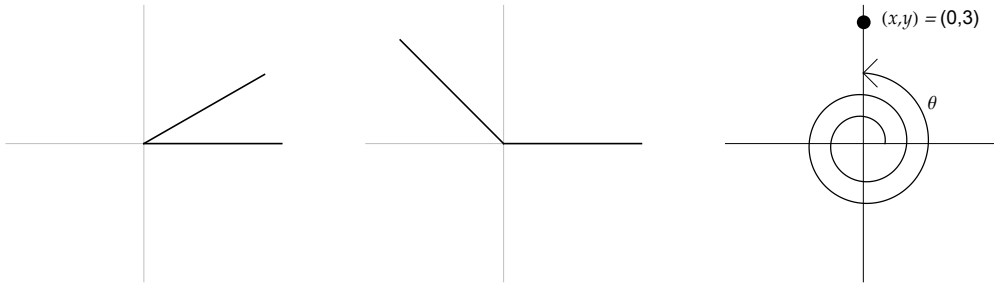

EXAMPLE 10

Suppose the point $(2, -3)$ is on the terminal side of angle θ when drawn in standard position.

- a) Determine the exact values of $\cos \theta$, $\sin \theta$ and $\tan \theta$ (“exact values” means no decimals).

- b) Determine the exact values of $\cos(\theta + 360^\circ)$ and $\tan(\theta - 720^\circ)$.

Signs of the trig functions**QUESTION**

For what kinds of angles θ is $\sin \theta$ positive? (What about $\cos \theta$?)

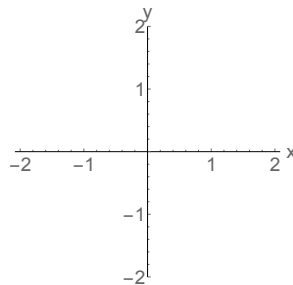

There is a pneumonic device to help you remember this:

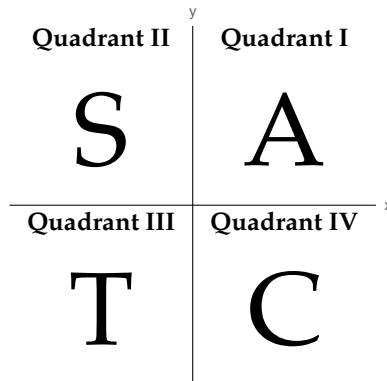

EXAMPLE 11

Determine whether or not the following quantities are positive or negative:

a) $\cos 241^\circ$

b) $\sin 815^\circ$

Solution: $815^\circ \sim 815^\circ - 720^\circ = 95^\circ$, so 815° is in Quadrant II, so $\sin 815^\circ$ is **positive**.

c) $\cos(-23^\circ)$

Solution: -23° is in Quadrant IV, so $\cos(-23^\circ)$ is **positive**.

d) $-3 \cos 110^\circ \sin 205^\circ$

Interpreting the angle definitions

From two pages ago, the angle definitions of the trig functions are:

$$\sin \theta = \frac{y}{r} \quad \cos \theta = \frac{x}{r} \quad \tan \theta = \frac{y}{x} \quad (r = \sqrt{x^2 + y^2})$$

To interpret these definitions appropriately, imagine “blowing up” the unit circle interpretation of the trig functions by a factor of r :

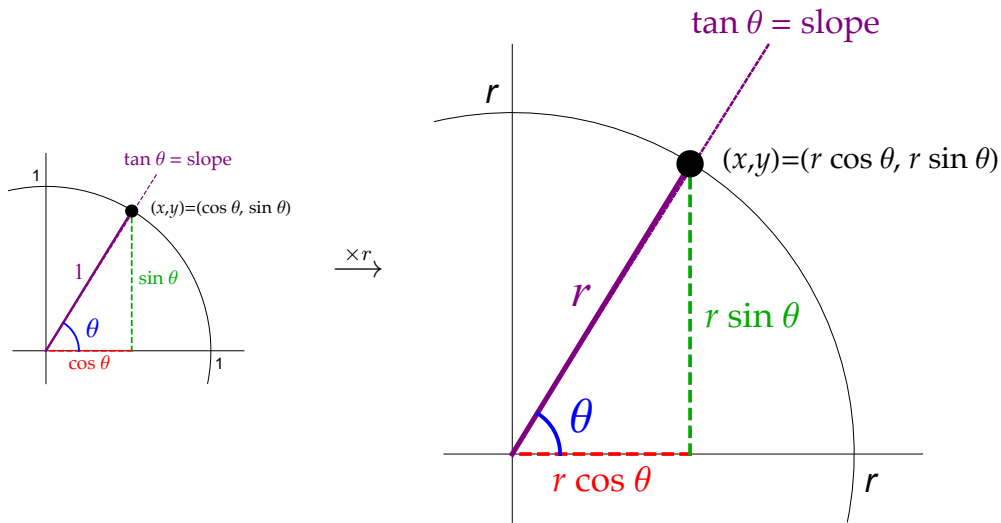

EXAMPLE 12

For each picture below, give a formula for the distance indicated by the “?” in terms of the angles marked on the picture:

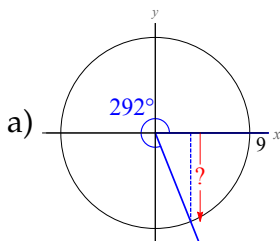

? =

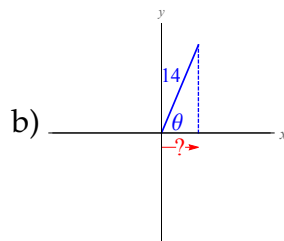

? =

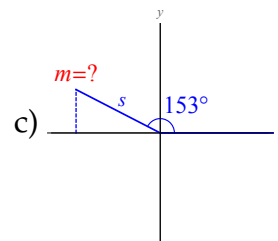

? =

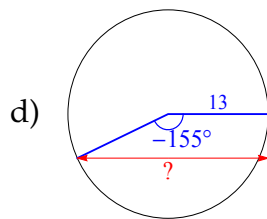

? =

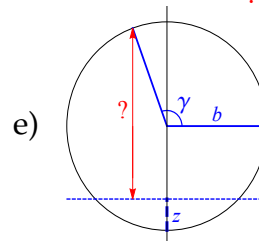

? =

3.3 Computing sines and cosines with a calculator

It turns out that you can determine $\sin \theta$, $\cos \theta$ and $\tan \theta$ algebraically (you learn these formulas in Calculus 2):

Definition 3.6 (Algebra/calculus definition of sine and cosine) *If θ is either a real number or an angle expressed in radians, then*

$$\sin \theta = \theta - \frac{\theta^3}{3 \cdot 2 \cdot 1} + \frac{\theta^5}{5 \cdot 4 \cdot 3 \cdot 2 \cdot 1} - \frac{\theta^7}{7 \cdot 6 \cdot 5 \cdot 4 \cdot 3 \cdot 2 \cdot 1} + \dots$$

and

$$\cos \theta = 1 - \frac{\theta^2}{2 \cdot 1} + \frac{\theta^4}{4 \cdot 3 \cdot 2 \cdot 1} - \frac{\theta^6}{6 \cdot 5 \cdot 4 \cdot 3 \cdot 2 \cdot 1} + \dots$$

A calculator will compute trig functions of an angle or number (make sure the mode is set correctly in degrees or radians) using the **SIN**, **COS** and/or **TAN** buttons; your calculator uses algebraic formulas like those above.

EXAMPLE 13

Use a calculator to compute these quantities:

a) $\sin 28^\circ$

(get .27 if in radian mode)

b) $\cos 66.35^\circ$

c) $\sin 71^\circ$

Solution: $\sin 71^\circ = \boxed{.945519}$.

d) $\cos 25.8^\circ$

Solution: $\cos 25.8^\circ = \boxed{.900319}$.

e) $\tan(15^\circ + 35^\circ)$

f) $\tan 15^\circ + \tan 35^\circ$

g) $\cos^2 65^\circ - 3 \tan 2 \cdot 71^\circ$

h) $4 \sin^3 115^\circ + 2$

IMPORTANT: In (c) above, it is totally correct to write " $\sin 71^\circ = .945519$ ".

But it is totally **NOT** OK to write " $\sin = .945519$ ".

This is because \sin is a function, and functions without inputs don't do anything. In nonsense like " $\sin = .945519$ ", the " \sin " is what I call "*naked*".

NAKED TRIG FUNCTIONS LEAD TO DEDUCTIONS.

Story problems involving rotation and length

EXAMPLE 14 (FROM SECTION 2.1)

If you get on the Ferris wheel of radius 80 ft shown below and go $\frac{3}{5}$ of the way around, how high off the ground are you?

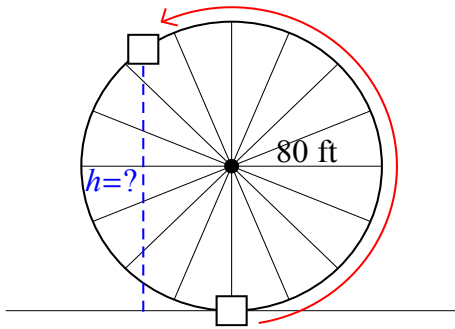

EXAMPLE 15

A bug sits on the right edge of a wheel of radius 5 cm. If the wheel rotates with an angular velocity of 14° per second, how far to the left or right of the center of the wheel is the bug after 23 seconds?

EXAMPLE 16

A teeter-totter is 8 feet long. If someone sits on the left side of the teeter-totter so that the left side tilts 24° downward,

- a) What is the slope of the teeter-totter?
- b) If the middle of the teeter-totter is 2.5 feet off the ground, how high is the right-most point of the teeter-totter?

Applications of sines and cosines to vectors

RECALL

In Chapter 2, we introduced **vectors**, which are mathematical objects with two attributes:

When a vector is drawn in standard position so that it starts at the origin, we named the vector by the coordinates of the point where it ends. This is called the **component form** of the vector.

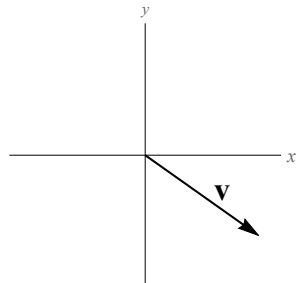

3.3. Computing sines and cosines with a calculator

Earlier, we saw that the magnitude of a vector \mathbf{v} , denoted $|\mathbf{v}|$, is computed from its components using the Pythagorean Theorem:

$$\mathbf{v} = \langle a, b \rangle \Rightarrow |\mathbf{v}| = \sqrt{a^2 + b^2}.$$

Now we can talk about the *direction* of a vector \mathbf{v} :

Definition 3.7 Let $\mathbf{v} = \langle a, b \rangle$ be a vector. The **direction angle** of \mathbf{v} is the angle made by \mathbf{v} (measured from the positive x -axis in the usual way), when \mathbf{v} is drawn in standard position. This angle is denoted $\theta_{\mathbf{v}}$.

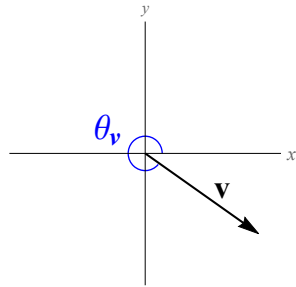

Theorem 3.8 (Component formulas) If vector \mathbf{v} has magnitude $|\mathbf{v}|$ and direction angle $\theta_{\mathbf{v}}$, then the component form of \mathbf{v} is

$$\mathbf{v} = \langle |\mathbf{v}| \cos \theta_{\mathbf{v}}, |\mathbf{v}| \sin \theta_{\mathbf{v}} \rangle.$$

EXAMPLE 17

Suppose that vector \mathbf{w} has magnitude 6 and direction angle 140° . Write \mathbf{w} in component form (i.e. as $\langle a, b \rangle$).

EXAMPLE 18

If $|\mathbf{v}| = 25.3$ and $\theta_{\mathbf{v}} = 292^\circ$, compute the horizontal component of \mathbf{v} .

Navigation problems

EXAMPLE 19

Suppose a plane takes off on a bearing 35° degrees west of north and flies for 100 miles. The plane then turns on a bearing of 70° west of north and flies for another 200 miles. Then, the plane turns on a bearing 30° west of south and flies for 125 miles. At this point, how far from the airport is the plane?

Picture:

Given:

$$|\mathbf{v}| = 100$$

$$\theta_{\mathbf{v}} = 125^\circ$$

$$|\mathbf{w}| = 200$$

$$\theta_{\mathbf{w}} = 160^\circ$$

$$|\mathbf{x}| = 125$$

$$\theta_{\mathbf{x}} = 240^\circ$$

Strategy:

1. Convert all vectors to components
2. Add them to get $\mathbf{v} + \mathbf{w} + \mathbf{x}$
3. Find magnitude of sum

3.4 Basic identities

What is an *identity*?

Periodicity

Theorem 3.9 (Periodicity) *Coterminal angles have the same trig functions:*

$$\sin(\theta \pm 360^\circ) = \sin \theta \quad \cos(\theta \pm 360^\circ) = \cos \theta \quad \tan(\theta \pm 360^\circ) = \tan \theta.$$

In radians, this means

$$\sin(\theta \pm 2\pi) = \sin \theta \quad \cos(\theta \pm 2\pi) = \cos \theta \quad \tan(\theta \pm 2\pi) = \tan \theta.$$

EXAMPLE 20

Suppose $\tan \beta = 3.2$. What is $\tan(\beta - 360^\circ)$?

Solution: $\tan(\beta - 360^\circ) = \tan \beta = \boxed{3.2}$.

The quotient identity

Theorem 3.10 (Quotient Identity) *For any angle or number θ ,*

$$\tan \theta = \frac{\sin \theta}{\cos \theta}.$$

EXAMPLE 21

a) Suppose $\sin \theta = \frac{5}{13}$ and $\cos \theta = \frac{-12}{13}$. Compute $\tan \theta$.

Solution: $\tan \theta = \frac{\sin \theta}{\cos \theta} = \frac{\frac{5}{13}}{\frac{-12}{13}} \stackrel{\text{FLIP DENOM.}}{=} \frac{5}{13} \cdot \frac{13}{-12} = \boxed{-\frac{5}{12}}$.

EXAMPLE 22

Suppose $\sin \theta = \frac{4}{9}$. Determine all possible values of $\cos \theta$. (Let's find exact values here without using a calculator.) But before finding $\cos \theta$, draw a picture to explain this problem.

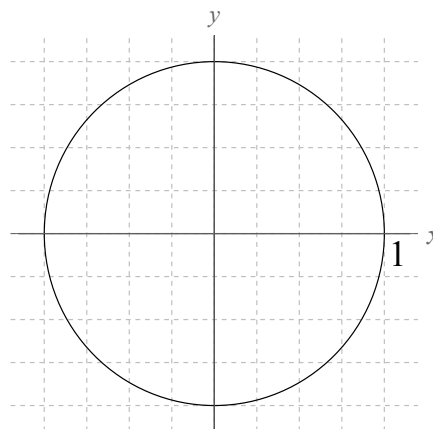

EXAMPLE 23

Suppose $\cos \theta = .35$ and $\sin \theta > 0$. Compute $\tan \theta$, and then draw a picture to explain this problem.

Strategy: First, we'll find $\sin \theta$; then we'll find $\tan \theta$.

Solution: First, we know $\cos^2 \theta + \sin^2 \theta = 1$. That means

$$\begin{aligned} (.35)^2 + \sin^2 \theta &= 1 \\ .1225 + \sin^2 \theta &= 1 \\ \sin^2 \theta &= 1 - .1225 \\ \sin^2 \theta &= .8775 \\ (\sin \theta)^2 &= .8775 \\ \sin \theta &= \pm \sqrt{.8775} \\ \sin \theta &= .93675 \end{aligned}$$

(choose the positive square root since we are given that $\sin \theta > 0$).

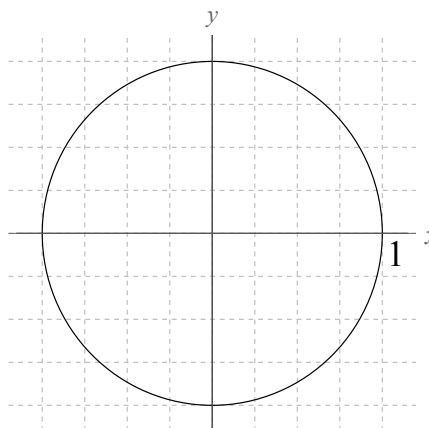

Finally, by the Quotient Identity $\tan \theta = \frac{\sin \theta}{\cos \theta} = \frac{.93675}{.35} = \boxed{2.67652}$.

3.5 Reflection properties

Cofunction identities

Theorem 3.12 (Cofunction identities) For any angle or number θ ,

$$\sin(90^\circ - \theta) = \cos \theta \quad \text{and} \quad \cos(90^\circ - \theta) = \sin \theta.$$

In radians, this is

$$\sin\left(\frac{\pi}{2} - \theta\right) = \cos \theta \quad \text{and} \quad \cos\left(\frac{\pi}{2} - \theta\right) = \sin \theta.$$

This identity explains why we use the word “cosine”:

“**co**sine” is short for “**si**ne of the **co**mplementary angle”.

Why is this identity true?

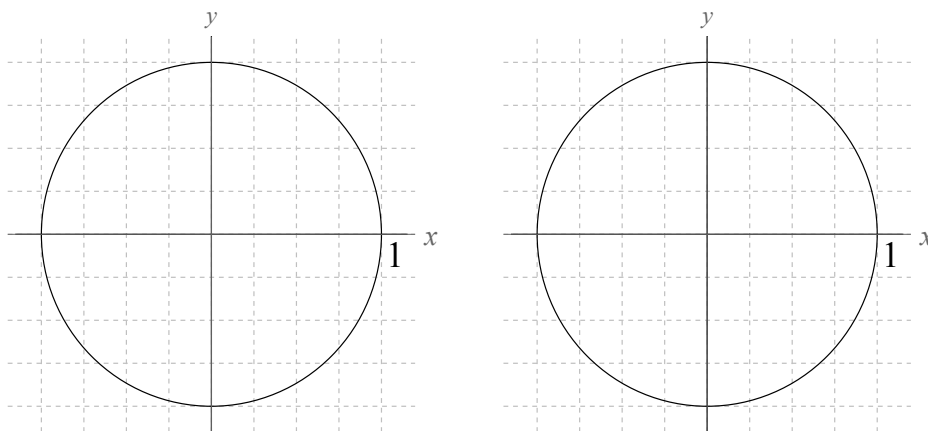
**EXAMPLE 24**

Suppose $\sin \theta = .35$. What is $\cos(90^\circ - \theta)$? What about $\cos(450^\circ - \theta)$?

Odd-even identities

Consider angles θ and $-\theta$. Suppose you computed the sine, cosine and tangent of these angles using the unit circle definition:

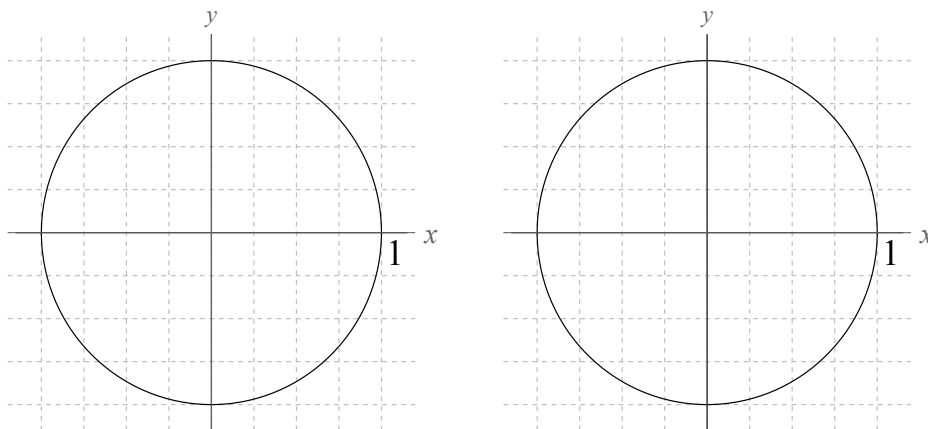

Theorem 3.13 (Odd-even identities) For any angle or number θ ,

$$\cos(-\theta) = \cos \theta \quad \sin(-\theta) = -\sin \theta \quad \tan(-\theta) = -\tan \theta.$$

EXAMPLE 25

- Suppose θ is some angle such that $\cos \theta = \frac{1}{5}$. Find $\cos(-\theta)$.
- Suppose θ is some angle such that $\sin \theta = \frac{-2}{3}$. Find $\sin(-\theta)$.
- Suppose θ is some angle such that $\tan \theta = \frac{1}{4}$. Find $\tan(-\theta)$.

Other reflections

EXAMPLE 25

Suppose $\sin \theta = \frac{2}{9}$. Evaluate each expression:

a) $\sin(180^\circ - \theta)$

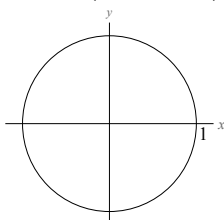

b) $\sin(\theta + 180^\circ)$

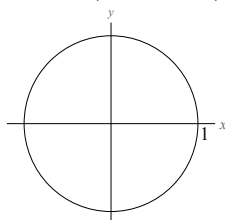

c) $\sin(-\theta)$

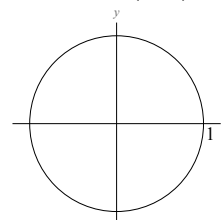

EXAMPLE 26

Suppose $\tan \theta = 4.1$. Evaluate each expression:

a) $\tan(\pi - \theta)$

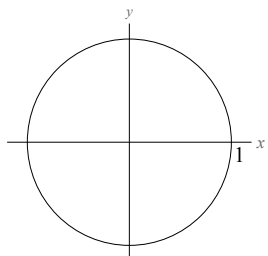

b) $\tan(\theta + \pi)$

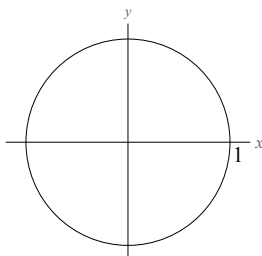

c) $\tan(4\pi - \theta)$

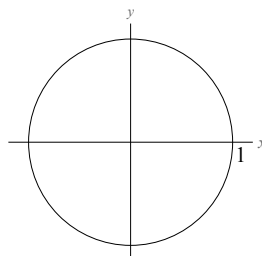

d) $\tan(3\pi - \theta)$

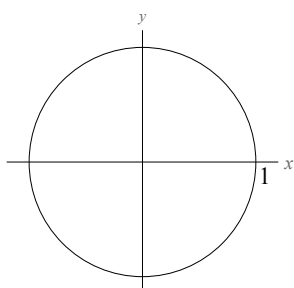

e) $\tan\left(\frac{\pi}{2} - \theta\right)$

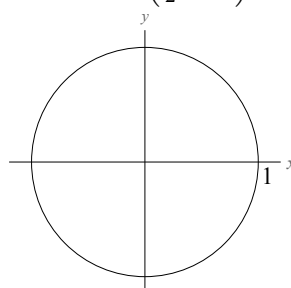

Trig functions and reference angles

Recall that a reference angle of θ is an angle $\hat{\theta}$ in Quadrant I which is symmetric with θ . We learned in Chapter 2 that if (x, y) is on the terminal side of $\hat{\theta}$, then $(\pm x, \pm y)$ is on the terminal side of θ . Therefore, since the trig functions are computed from such a point, we know:

Theorem 3.14 *If $\hat{\theta}$ is the reference angle of θ , then*

$$\sin \theta = \pm \sin \hat{\theta} \text{ and } \cos \theta = \pm \cos \hat{\theta}.$$

So to find a trig function of **any** angle θ , we can find the trig function of its reference angle $\hat{\theta}$ and then slap a + or - sign on the answer to get the trig function of θ .

3.6 Sines, cosines and tangents of special angles

A “special angle” is any multiple of 30° or any multiple of 45° , i.e. angles like

$$0^\circ, 30^\circ, 60^\circ, 90^\circ, 120^\circ, 150^\circ, -30^\circ, -60^\circ, -90^\circ, -120^\circ, -150^\circ, \dots$$

$$45^\circ, 90^\circ, 135^\circ, 180^\circ, 225^\circ, -45^\circ, -90^\circ, -135^\circ, -180^\circ, -225^\circ, \dots$$

In radians, these special angles are any multiple of $\frac{\pi}{6}$, any multiple of $\frac{\pi}{4}$, any multiple of $\frac{\pi}{3}$, any multiple of $\frac{\pi}{2}$ or any multiple of π :

$$\frac{\pi}{6}, \frac{5\pi}{6}, \frac{-\pi}{6}, \frac{-5\pi}{6}, \frac{7\pi}{6}, \frac{-7\pi}{6}, \frac{\pi}{3}, \frac{-\pi}{3}, \frac{3\pi}{4}, \frac{-5\pi}{4}, \frac{3\pi}{2}, \frac{-5\pi}{2}, 0, \pi, -2\pi, 3\pi, \dots$$

These are the angles you get when you divide a right angle into halves or thirds, and are the most commonly used angles in math courses and in real-world situations.

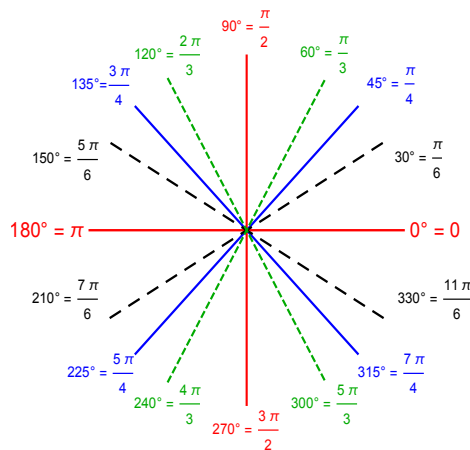

The goal of this section is to learn how to compute the exact values of the sine, cosine and/or tangent of any special angle **quickly** and **without using a calculator**.

We'll start by learning the sine, cosine and tangent of special angles in Quadrant I.

Special angles in Quadrant I

I'm going to derive the sine, cosine and tangent of these angles below; **you should memorize (or internalize) these answers:**

$$0^\circ = 0$$

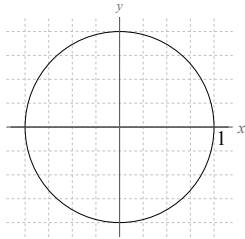

$$\Rightarrow \begin{cases} \sin 0^\circ = y = \boxed{0} \\ \cos 0^\circ = x = \boxed{1} \\ \tan 0^\circ = \text{slope at } 0^\circ = \boxed{0} \\ \text{(slope of horizontal line is 0)} \end{cases}$$

$$90^\circ = \frac{\pi}{2}$$

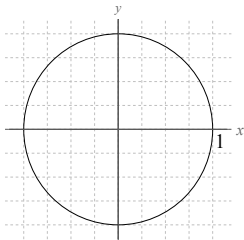

$$\Rightarrow \begin{cases} \sin 90^\circ = y = \boxed{1} \\ \cos 90^\circ = x = \boxed{0} \\ \tan 90^\circ = \text{slope at } 90^\circ = \boxed{\text{DNE}} \\ \text{(slope of vertical line is undefined)} \end{cases}$$

$$45^\circ = \frac{\pi}{4}$$

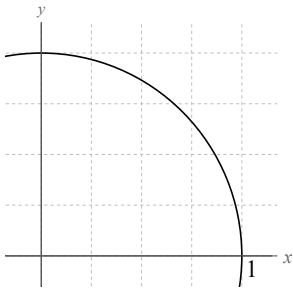

$$\Rightarrow \begin{cases} \sin 45^\circ = y = \\ \cos 45^\circ = x = \\ \tan 45^\circ = \text{slope at } 45^\circ = \end{cases}$$

$$60^\circ = \frac{\pi}{3}$$

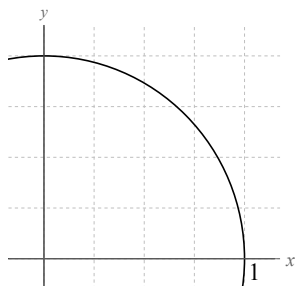

$$\Rightarrow \begin{cases} \sin 60^\circ = y = \\ \cos 60^\circ = x = \\ \tan 60^\circ = \frac{\sin 60^\circ}{\cos 60^\circ} = \end{cases}$$

3.6. Sines, cosines and tangents of special angles

$$30^\circ = \frac{\pi}{6}$$

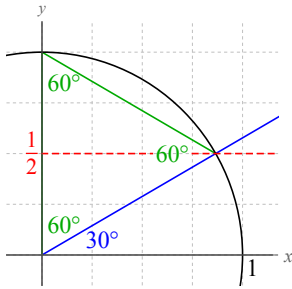

$$\Rightarrow \begin{cases} \sin 30^\circ = y = \frac{1}{2} \\ \cos 30^\circ = x = \frac{\sqrt{3}}{2} \\ \tan 30^\circ = \frac{\sin 30^\circ}{\cos 30^\circ} = \frac{\frac{1}{2}}{\frac{\sqrt{3}}{2}} = \frac{1}{\sqrt{3}} \end{cases}$$

To summarize, we have learned the following:

Theorem 3.15 (Sines, cosines and tangents of special angles)				
θ in degrees	θ in radians	$\sin \theta$	$\cos \theta$	$\tan \theta$
0°	0	0	1	0
30°	$\frac{\pi}{6}$	$\frac{1}{2}$	$\frac{\sqrt{3}}{2}$	$\frac{1}{\sqrt{3}}$
45°	$\frac{\pi}{4}$	$\frac{\sqrt{2}}{2}$	$\frac{\sqrt{2}}{2}$	1
60°	$\frac{\pi}{3}$	$\frac{\sqrt{3}}{2}$	$\frac{1}{2}$	$\sqrt{3}$
90°	$\frac{\pi}{2}$	1	0	DNE

How do you remember these?

Either remember the triangles on the previous page, or use this **finger counting trick**:

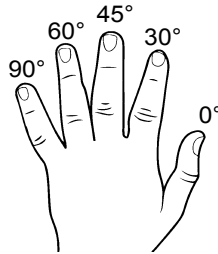

To compute trig functions of special angles in Quadrant I:

1. Label the fingers on your left hand as above.
2. Use your right hand to grab the finger corresponding to the angle you want.
3. Count fingers:
 - a) For **cosine**, count the fingers to the **left** of the finger you grabbed (towards 90°). Take the square root of that, put it over 2:

$$\cos \theta = \frac{\sqrt{\# \text{ fingers to the left}}}{2}$$

- b) For **sine**, count the fingers to the **right** of the finger you grabbed (towards 0°). Like cosine, take the square root of that, put it over 2:

$$\sin \theta = \frac{\sqrt{\# \text{ fingers to the right}}}{2}$$

- c) For tangent, count both the fingers to the left and the right, and make this fraction with square roots:

$$\tan \theta = \frac{\sqrt{\# \text{ fingers to the right}}}{\sqrt{\# \text{ fingers to the left}}}$$

- d) Never count the finger that you grabbed.

TWO QUICK EXAMPLES

a) $\cos \frac{\pi}{3}$

b) $\sin 30^\circ$

3.6. Sines, cosines and tangents of special angles

EXAMPLE 27

Try to do these without looking back at the previous page, and without writing any scratch work or tables:

a) $\cos 30^\circ$

f) $\sin \frac{\pi}{3}$

b) $\tan 45^\circ$

g) $\cos \frac{\pi}{4}$

c) $\cos \frac{\pi}{2}$

h) $\cos 0$

d) $\sin 45^\circ$

i) $\sin 90^\circ$

e) $\tan 60^\circ$

j) $\tan \frac{\pi}{6}$

EXAMPLE 28

Compute each quantity:

a) $3 \cos(30^\circ + 30^\circ)$

b) $\sin \frac{\pi}{4} + \tan \frac{\pi}{2}$

c) $20 \cos^2 \frac{\pi}{3}$

d) $\tan 30^\circ \sin 30^\circ$

e) $\tan 45^\circ + \cos 0^\circ$

Trig functions of arbitrary special angles

Now, we turn to computing sines, cosines and/or tangents of special angles in any quadrant. Here's how we do this:

- If the angle θ is quadrantal (i.e. a multiple of 90° or $\frac{\pi}{2}$), we find the point on the unit circle at θ . The x -coordinate of this point is $\cos \theta$, the y -coordinate of this point is $\sin \theta$, and the slope of the line from the origin to this point is $\tan \theta$.
- If the angle θ is not quadrantal, we
 1. use the finger counting trick to determine $\sin \theta$ and/or $\cos \theta$ for angles in the first quadrant;
 2. memorize the tangents of 30° , 45° and 60° ;
 3. and use symmetry / reference angles (together with the finger counting trick) for other angles. The important ingredients of this method are below:

Theorem 3.16 *If θ is in radians, expressed as a fraction $\theta = \frac{a\pi}{b}$ where $\frac{a}{b}$ is in lowest terms and $b = 2, 3, 4,$ or 6 , then the reference angle of θ is $\hat{\theta} = \frac{\pi}{b}$.*

Theorem 3.17 *If $\hat{\theta}$ is the reference angle of θ , we know*

$$\sin \theta = \pm \sin \hat{\theta} \quad \cos \theta = \pm \cos \hat{\theta} \quad \tan \theta = \pm \tan \hat{\theta}.$$

“All Scholars Take Calculus”

Quadrant II		Quadrant I
S		A
Quadrant III		Quadrant IV
T		C

3.6. Sines, cosines and tangents of special angles

	EXAMPLE A	EXAMPLE B	EXAMPLE C
STEPS	$\sin 240^\circ$	$\tan \frac{-7\pi}{4}$	$\sin 900^\circ$
<p>1. Is θ quadrantal?</p> <p>(If necessary, convert (θ to degrees, and add or subtract 360° to figure this out.)</p>			
<p>2. If θ is quadrantal, find point on unit circle at angle θ.</p> <p>(This point must be either $(0, \pm 1)$ or $(\pm 1, 0)$.)</p> <p>Then read off answer: $\cos \theta = x$; $\sin \theta = y$; $\tan \theta = \text{slope}$.</p>			
<p>3. If θ is not quadrantal, determine two items:</p> <p>First, the quadrant θ lies in. (If necessary, convert θ to degrees, and add or subtract 360° to figure this out.) Use the ASTC rules to determine the sign of your final answer.</p> <p>Second, the reference angle of θ. It is: 30°, if $\theta = \frac{N\pi}{6}$ or if θ is "shallow"; 45°, if $\theta = \frac{N\pi}{4}$ or if θ is "diagonal"; 60°, if $\theta = \frac{N\pi}{3}$ or if θ is "steep".</p> <p>Take sin, cos or tan of the reference angle, and use the sign from earlier to get the final answer.</p>			

3.6. Sines, cosines and tangents of special angles

Problem	Is θ quadrantal?	If θ is quadrantal:			If θ is not quadrantal:			
		Find point on unit circle at θ	Write answer	Find quadrant	Sign of answer	Reference angle $\hat{\theta}$	$\sin/\cos/\tan$ of ref. angle	Write answer
$\sin \frac{-11\pi}{6}$								
$\tan \frac{4\pi}{3}$								
$\sin 300^\circ$								
$\cos \frac{5\pi}{4}$								
$\cos 720^\circ$								

EXAMPLE 29

Compute each quantity:

a) $\tan \frac{5\pi}{6}$

b) $\sin -210^\circ$

c) $\cos 810^\circ$

d) $\sin \left(\frac{\pi}{6} + \frac{5\pi}{6} \right)$

e) $3 \tan^2 \frac{2\pi}{3}$

f) $\cos \pi \sin \frac{3\pi}{4}$

$$\text{g) } \tan \frac{-11\pi}{4} + 3 \sin \frac{-\pi}{2}$$

$$\text{h) } \cos 135^\circ + \sin 300^\circ$$

3.7 Arcsine, arccosine and arctangent

We have learned that the trig functions convert a rotational measurement (i.e. an angle) to a distance/length measurement:

$$\theta \xrightarrow{\sin} \sin \theta = y \text{ on the unit circle}$$

$$\theta \xrightarrow{\cos} \cos \theta = x \text{ on the unit circle}$$

$$\theta \xrightarrow{\tan} \tan \theta = \frac{y}{x} = \text{slope at angle } \theta$$

MOTIVATING QUESTION

How do we go backwards? If we know what the x -coordinate, or y -coordinate, or slope of an angle θ , can we figure out what θ is? If so, how?

$$\theta \xleftarrow{?} \sin \theta = y$$

$$\theta \xleftarrow{?} \cos \theta = x$$

$$\theta \xleftarrow{?} \tan \theta = \text{slope}$$

Long story short:

EXAMPLE 30

Find an angle θ between 0° and 90° such that $\sin \theta = \frac{1}{2}$.

Solution: From special angles, we know $\theta = \boxed{}$ works.

EXAMPLE 30 (VERSION 2)

Find all angles between 0° and 360° such that $\sin \theta = \frac{1}{2}$.

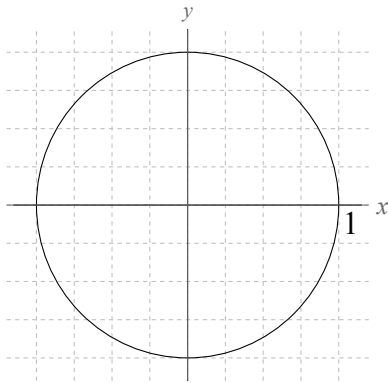

EXAMPLE 31

Find an angle θ between 0° and 180° such that $\cos \theta = \frac{\sqrt{2}}{2}$.

Solution: From special angles, we know $\theta = \boxed{}$ works.

EXAMPLE 31 (VERSION 2)

Find all angles between 0° and 360° such that $\cos \theta = \frac{\sqrt{2}}{2}$.

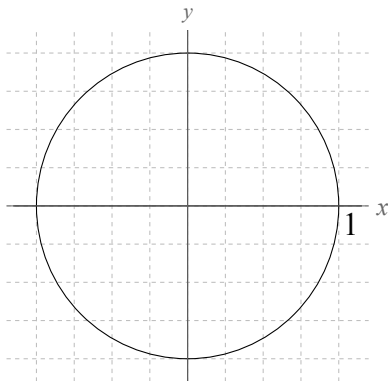

Arcsine

Suppose you are trying to find θ if $\sin \theta = q$. This means you are looking for a point on the unit circle whose _____ equals q .

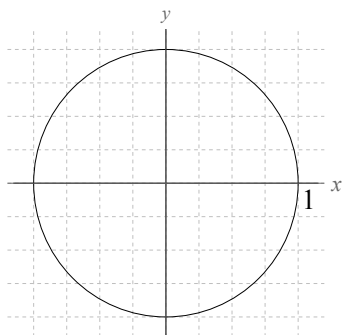

So in general, the equation $\sin \theta = q$ has two different solutions. That means we **cannot use a function** to get from $q = \sin \theta$ back to θ (because the function would have to have two outputs).

BUT: If we specify how to consistently choose one of the two angles that works, we do get a function which produces **a** (not **the**) θ from $\sin \theta$.

Enrichment: This is kind of like how if you are solving $x^2 = q$ for x , you get

$$x = \pm\sqrt{q},$$

so you can't get from q back to x with a function (because you'd have to have two outputs for your x).

But if you always choose the positive x that works, then that x is $x = \sqrt{q}$, which gives one of the x s as a function of q .

More on this in MATH 130, when you talk about one-to-one functions and inverses.

Definition 3.18 Suppose $-1 \leq q \leq 1$. The **arcsine** of q , denoted $\arcsin q$, is the angle θ in Quadrant I or IV (i.e. $-90^\circ \leq \theta \leq 90^\circ$) whose sine is q , i.e.

$$\theta = \arcsin q \quad \text{means} \quad \begin{cases} \sin \theta = q \\ \text{and} \\ -90^\circ \leq \theta \leq 90^\circ. \end{cases}$$

If $q < -1$ or $q > 1$, then $\arcsin q$ is undefined.

\arcsin is also called “inverse sine” and is also denoted “ \sin^{-1} ”.

Theorem 3.19 (The equation $\sin \theta = q$) Let q be a number.

- If $q < -1$ or $q > 1$, then the equation $\sin \theta = q$ has no solution.
- If $q = -1$, the equation $\sin \theta = q$ has one solution between 0° and 360° : $\theta = 270^\circ$.
- If $q = 1$, the equation $\sin \theta = q$ has one solution between 0° and 360° : $\theta = 90^\circ$.
- If $-1 < q < 1$, the equation $\sin \theta = q$ has two solutions between 0° and 360° .

The first solution is $\arcsin q$, which you get by typing $\boxed{\text{SIN}^{-1}} q$ on a calculator.

The other solution is $180^\circ - \arcsin q$.

EXAMPLE 32

Find all angles between 0° and 360° that solve each equation:

a) $\sin \theta = .307$

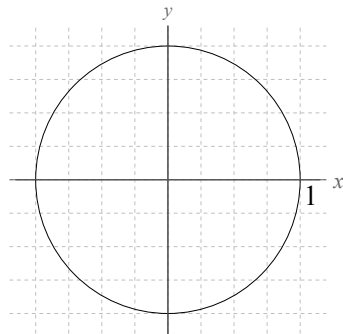

b) $\sin \theta = 2$

c) $\sin \theta = -\frac{8}{19}$

Arccosine

Now suppose you are trying to solve $\cos \theta = q$. This means you are looking for a point on the unit circle whose _____ equals q .

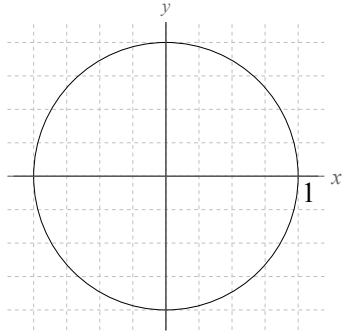

There are two of these angles, but if you require that the angle is in Quadrant I or II, you only get one angle. Therefore, we define

Definition 3.20 Suppose $-1 \leq q \leq 1$. The **arccosine** of q , denoted $\arccos q$, is the angle θ in Quadrant I or II (i.e. $0^\circ \leq \theta \leq 180^\circ$) whose cosine is q , i.e.

$$\theta = \arccos q \quad \text{means} \quad \begin{cases} \cos \theta = q \\ \text{and} \\ 0^\circ \leq \theta \leq 180^\circ. \end{cases}$$

If $q < -1$ or $q > 1$, then $\arccos q$ is undefined.

\arccos is also called “inverse cosine” and is also denoted “ \cos^{-1} ”.

Theorem 3.21 (The equation $\cos \theta = q$) Let q be a number.

- If $q < -1$ or $q > 1$, then the equation $\cos \theta = q$ has no solution.
- If $q = -1$, the equation $\cos \theta = q$ has one solution between 0° and 360° : $\theta = 0^\circ$.
- If $q = 1$, the equation $\cos \theta = q$ has one solution between 0° and 360° : $\theta = 180^\circ$.
- If $-1 < q < 1$, the equation $\cos \theta = q$ has two solutions between 0° and 360° .

The first solution is $\arccos q$, which you get by typing $\boxed{\text{COS}^{-1}}$ q on a calculator.

The other solution is $360^\circ - \arccos q$.

EXAMPLE 33

Determine all angles between 0° and 360° such that $\cos \theta = -.17$.

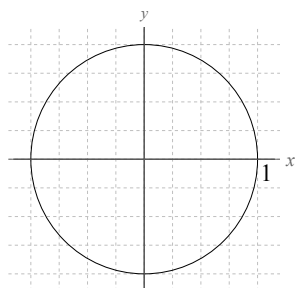
**Arctangent**

Now, suppose you are trying to solve $\tan \theta = q$. This means you are looking for an angle whose _____ equals q .

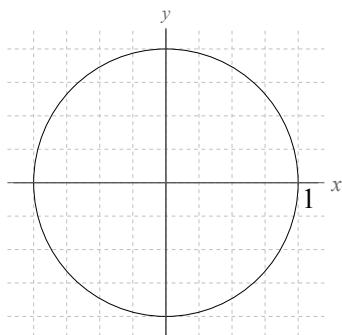

There are two of these angles (which must be opposite one another), but if you require that the angle is in Quadrant I or IV, you only get one angle. Therefore, we define:

Definition 3.22 Let q be any number. The **arctangent** of q , denoted $\arctan q$, is the angle θ in Quadrant I or IV (i.e. $-90^\circ \leq \theta \leq 90^\circ$) whose tangent is q , i.e.

$$\theta = \arctan q \text{ means } \begin{cases} \tan \theta = q \\ \text{and} \\ -90^\circ \leq \theta \leq 90^\circ. \end{cases}$$

\arctan is also called “inverse tangent” and is also denoted “ \tan^{-1} ”.

Theorem 3.23 (The equation $\tan \theta = q$) Let q be a number.

- The equation $\tan \theta = q$ always has two solutions between 0° and 360° .
The first solution is $\arctan q$, which you get by typing $\boxed{\text{TAN}^{-1}} q$ on a calculator.
The other solution is $180^\circ + \arctan q$.

EXAMPLE 34

Find all angles between 0° and 360° that solve each equation:

a) $\tan \theta = \frac{13}{24}$

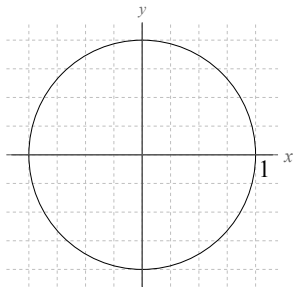

b) $\tan \theta = -2.12$

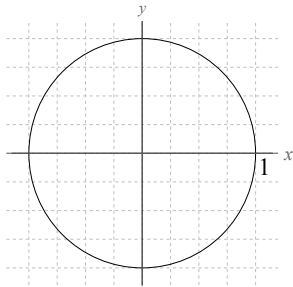

Summary of arcsin, arccos and arctan

$\theta \begin{matrix} \xrightarrow{\sin} \\ \xleftarrow{\arcsin} \end{matrix} \sin \theta = y$ (and $180^\circ - \arcsin y$)	$\theta \begin{matrix} \xrightarrow{\cos} \\ \xleftarrow{\arccos} \end{matrix} \cos \theta = x$ (and $360^\circ - \arccos x$)	$\theta \begin{matrix} \xrightarrow{\tan} \\ \xleftarrow{\arctan} \end{matrix} \tan \theta = \text{slope}$ (and $180^\circ + \arctan m$)
--	--	---

Computing direction angles of vectors

RECALL

The two important attributes of a vector are its _____ (a.k.a. its size) and its _____ .

Earlier, we saw how to use the Pythagorean Theorem to compute the magnitude of a vector, and we saw how to write a vector in component form, given its magnitude and direction angle. Now, we can derive a formula for the direction angle θ_v of a vector \mathbf{v} in terms of its components:

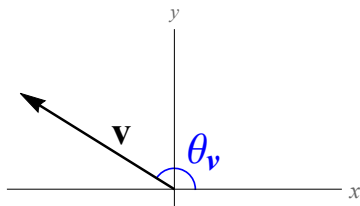

Theorem 3.24 (Direction angle formula) *The direction angle θ_v of vector $\mathbf{v} = \langle a, b \rangle$ is*

$$\theta_v = \arctan \frac{b}{a},$$

with the caveat that you may have to add/subtract 180° to get the angle in the correct quadrant.

EXAMPLE 35

- a) Compute the direction angle of $\langle 8, 5 \rangle$. Explain (using a picture) what this computation means.

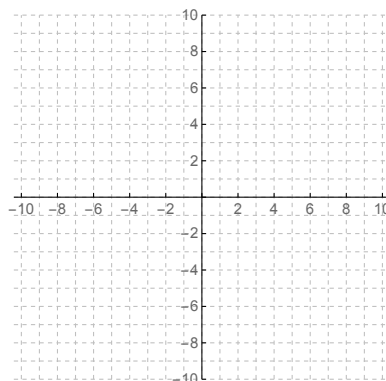

b) Compute the direction angle of $\langle -3, 5 \rangle$.

c) Compute the direction angle of $\mathbf{w} = \langle -4, 0 \rangle$.

Solution: $\theta_{\mathbf{w}} = \arctan \frac{b}{a} = \arctan \frac{0}{-4} = \arctan 0 = 0^\circ$.

But this points the wrong way (0° is to the right, but $\langle -4, 0 \rangle$ is to the left), so we need to add 180° to fix this.

Therefore $\theta_{\mathbf{w}} = 0^\circ + 180^\circ = \boxed{180^\circ}$.

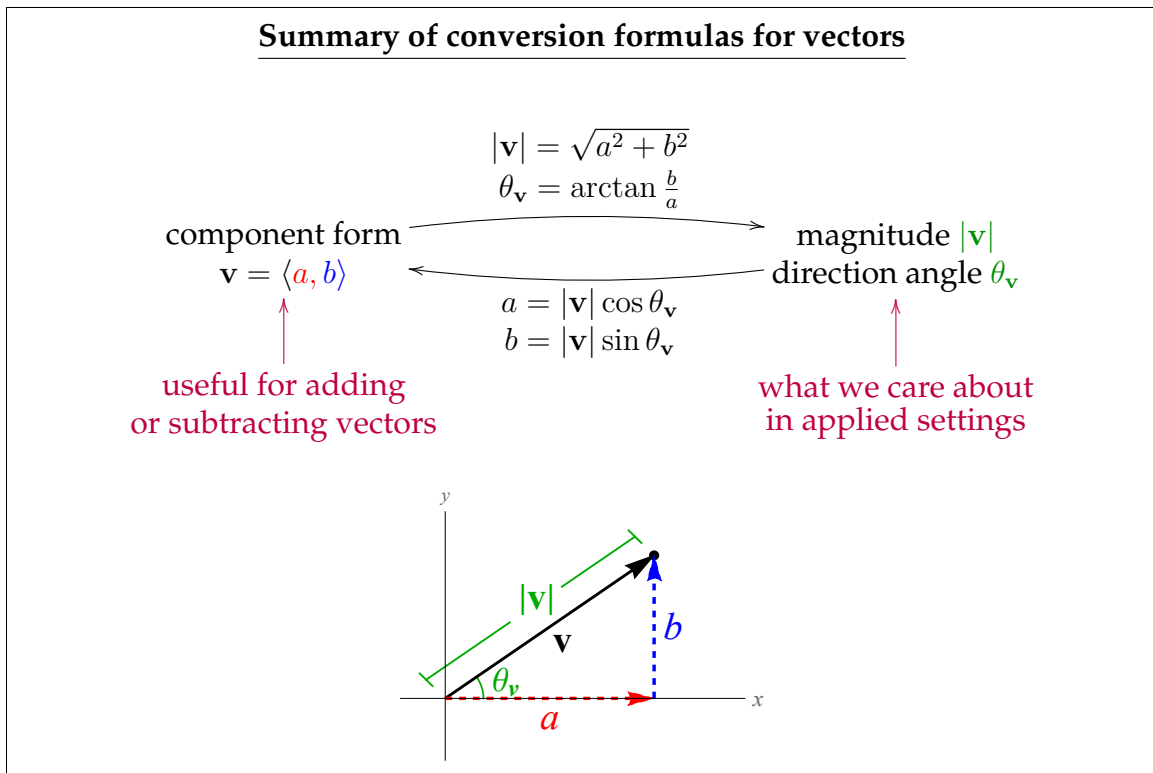

EXAMPLE 36

Two people push on a large box. One person applies a force of 70 newtons and another person applies a force of 85 newtons. If the angle between these two forces is 25° , in what direction does the box move?

Chapter 4

Triangle trigonometry

In the previous chapter, we learned how the three functions \sin , \cos and \tan can be used to convert measurements of rotation into measurements of length.

Now, we will study how the same functions can be used to determine lengths by means of auxiliary measurements. Our focus will be on **solving triangles**, which means determining any missing side lengths and any missing angle measures in a triangle.

Example:

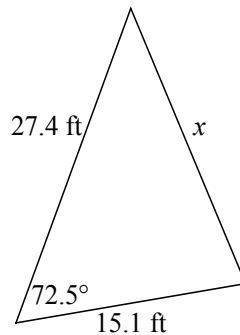

Notation

We label the three sides of a triangle with lowercase English letters, and the three angles with the same three capital English letters.

Important convention: In a triangle, the side length labelled with a lowercase English letter should always be opposite the angle with the corresponding capital letter:

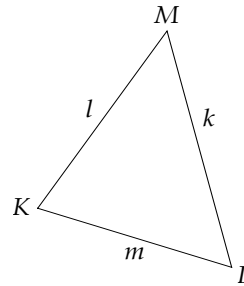
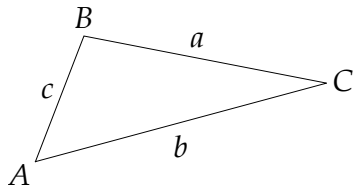

Always keep in mind

Whenever you know two angles of a triangle, you can figure the third, because the sum of the three angles in a triangle is 180° .

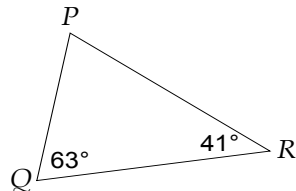

General strategy

To decide how to proceed when solving a triangle, we read off any given information around the triangle, recording known sides as S and known angles as A.

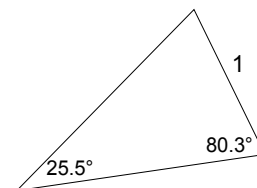
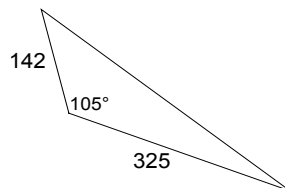
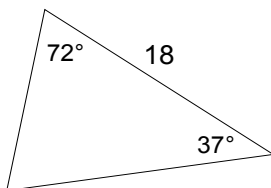

Depending on what things you are given (AAS vs. SAS vs. SSS vs. SSA, etc.), you start solving a triangle with different procedures.

4.1 Law of Sines

We are going to derive a formula that relates the angles of any triangle to its side lengths. Let's start with $\triangle ABC$ and draw in a perpendicular line from C to the opposite side as shown here:

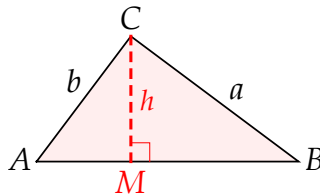

Now, we will figure h in two different ways, using rotational trigonometry from the last chapter. First, put the point A at the origin and think of a circle of radius b :

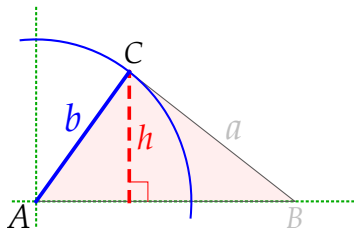

Second, flip the triangle over, put B at the origin, and think of a circle of radius a :

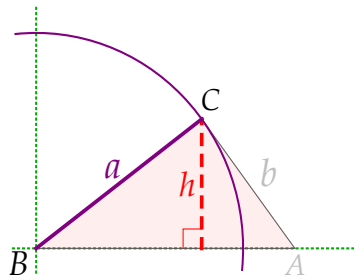

We have found that

$$h = b \sin A \quad \text{and} \quad h = a \sin B$$

There's nothing special about using A and B on the previous page; we could have just as easily used A and C (or B and C). So we can conclude the following important fact, which holds for any triangle:

Theorem 4.1 (Law of Sines) *In any triangle with vertices labelled A , B and C and respective sides labelled a , b and c ,*

$$\frac{\sin A}{a} = \frac{\sin B}{b} = \frac{\sin C}{c}.$$

Law of Sines Situation # 1: you know two angles and a side (ASA/AAS/SAA)

In this situation, you know two angles and the side length between the two known angles.

EXAMPLE 1

Solve triangle ABC , if $\angle A = 41^\circ$, $\angle B = 66^\circ$ and $c = 15.3$.

(Here is a box for you to record your final answers)

$\angle A = 41^\circ$	$\angle B = 66^\circ$	$\angle C =$
$a =$	$b =$	$c = 15.3$

Solution:

EXAMPLE 2

Solve triangle ABC if $\angle A = 71.3^\circ$, $\angle B = 58.8^\circ$ and $a = 2.75$.

$\angle A = 71.3^\circ$	$\angle B = 58.8^\circ$	$\angle C =$
$a = 2.75$	$b =$	$c =$

Solution:

EXAMPLE 3

Solve triangle JKL , if $\angle K = 25^\circ$, $\angle L = 104^\circ$ and $j = 250$.

Solution: First, draw a picture (it is not important that the picture shows the angles or lengths accurately):

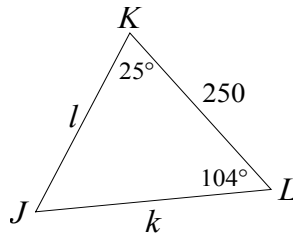

Second, find the third angle: $\angle J = 180^\circ - 25^\circ - 104^\circ = 51^\circ$.

Third, find side k using the Law of Sines (you could do l first):

$$\begin{aligned}\frac{\sin K}{k} &= \frac{\sin J}{j} \\ \frac{\sin 25^\circ}{k} &= \frac{\sin 51^\circ}{250} \\ \frac{.422618}{k} &= \frac{.777146}{250} \quad (\text{cross-multiply to get the next line}) \\ .777146 k &= 105.655 \\ k &= \frac{105.655}{.777146} = 135.95.\end{aligned}$$

Last, find side l , again using the Law of Sines:

$$\begin{aligned}\frac{\sin L}{l} &= \frac{\sin J}{j} \\ \frac{\sin 104^\circ}{l} &= \frac{\sin 51^\circ}{250} \\ \frac{.970296}{l} &= \frac{.777146}{250} \quad (\text{cross-multiply to get the next line}) \\ .777146 l &= 242.574 \\ l &= \frac{242.574}{.777146} = 312.13.\end{aligned}$$

WARNING: Do not use the Pythagorean Theorem. This is not a right triangle.

$\angle J = 51^\circ$	$\angle K = 25^\circ$	$\angle L = 104^\circ$
$j = 250$	$k = 135.95$	$l = 312.13$

EXAMPLE 4

Solve right triangle ABC , if $b = 200$ and $\angle A = 40^\circ$.

$\angle A = 40^\circ$	$\angle B =$	$\angle C =$
$a =$	$b = 200$	$c =$

Solution:

EXAMPLE 5

Solve right triangle ABC , if $a = 14$ and $\angle A = 27^\circ$.

Solution: First, since this is a right triangle, $\angle C = 90^\circ$.
Now, we can draw a picture:

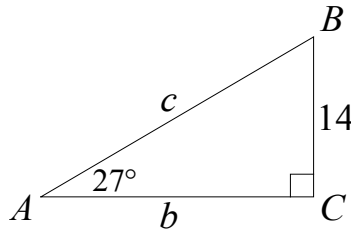

Second, $\angle B = 180^\circ - 90^\circ - 27^\circ = 63^\circ$.

Third, use the Law of Sines to find b (you could do c first):

$$\begin{aligned}\frac{\sin B}{b} &= \frac{\sin A}{a} \\ \frac{\sin 63^\circ}{b} &= \frac{\sin 27^\circ}{14} \\ \frac{.891007}{b} &= \frac{.45399}{14} \\ .45399b &= 12.4741 \\ b &= \frac{12.4741}{.45399} = 27.477.\end{aligned}$$

Last, use the Law of Sines to find c ... or, since this is a right \triangle , use the Pythagorean Theorem:

$$\begin{aligned}\frac{\sin C}{c} &= \frac{\sin A}{a} \\ \frac{\sin 90^\circ}{c} &= \frac{\sin 27^\circ}{14} & c^2 &= a^2 + b^2 \\ \frac{1}{c} &= \frac{.45399}{14} & c^2 &= 14^2 + 27.477^2 \\ .45399c &= 14 & c^2 &= 950.958 \\ c &= \frac{14}{.45399} = 30.838 & c &= \sqrt{950.958} = 30.838\end{aligned}$$

$\angle A = 27^\circ$	$\angle B = 63^\circ$	$\angle C = 90^\circ$
$a = 14$	$b = 27.477$	$c = 30.838$

Story problems involving the Law of Sines

In this situation, draw a picture and fill in the angles and/or side lengths that you know. Then proceed as on the previous pages.

VOCABULARY

An **angle of elevation** is an angle measured upward **from the horizontal**; an **angle of depression** is an angle measured downward **from the horizontal**.

EXAMPLE 6

A plane is flying at an altitude of 12,500 feet. The pilot notices that her angle of depression to a radar tower is 25° . How far is the plane from the radar tower?

EXAMPLE 7

A person walks 100 feet away from the base of a building, turns around and notices that the angle of elevation from their eyes to the top of the building is 72° . If the person's eyes are 6 feet above the ground, how tall is the building?

Law of Sines Situation # 2: SSA

In this situation, you know two side lengths and an angle which is not between the two known side lengths. **This situation is hard** and is called the **ambiguous case** of the Law of Sines.

WARMUP

How do you solve the equation $\sin \theta = q$?

Theorem 4.2 (Solving $\sin \theta = q$) *Let q be a constant.*

1. *If $q = 1$, then the equation $\sin \theta = q$ has one solution between 0° and 360° : $q = 90^\circ$.*
2. *If $q = -1$, then the equation $\sin \theta = q$ has one solution between 0° and 360° : $q = 270^\circ$.*
3. *If $-1 < q < 1$, then the equation $\sin \theta = q$ has two solutions between 0° and 360° : $\arcsin q$ and $180^\circ - \arcsin q$.*
4. *If $q < -1$ or $q > 1$, then the equation $\sin \theta = q$ has no solution.*

Recall that $\arcsin q$ is computed on a calculator with the $\boxed{\text{SIN}^{-1}}$ button.

EXAMPLES

- a) Find all θ between 0° and 360° such that $\sin \theta = .735$.

- b) Find all θ between 0° and 360° such that $\sin \theta = -.45$.
Solution: From a calculator, $\arcsin -.45 = -26.74^\circ$.
 Adding 360° to make this between 0° and 360° gives $-26.74^\circ + 360^\circ = 333.26^\circ$.
 The other solution is 180° minus the original answer,
 which is $180^\circ - (-26.74^\circ) = 206.74^\circ$.

- c) Find all θ between 0° and 360° such that $\sin \theta = 1$.

- d) Find all θ between 0° and 360° such that $\sin \theta = 1.578$.

EXAMPLE 8

Solve triangle ABC , if $\angle B = 55^\circ$, $b = 13.5$ and $a = 25.6$.

$\angle A =$	$\angle B = 55^\circ$	$\angle C =$
$a = 25.6$	$b = 13.5$	$c =$

Solution:

What went wrong here (geometrically)?

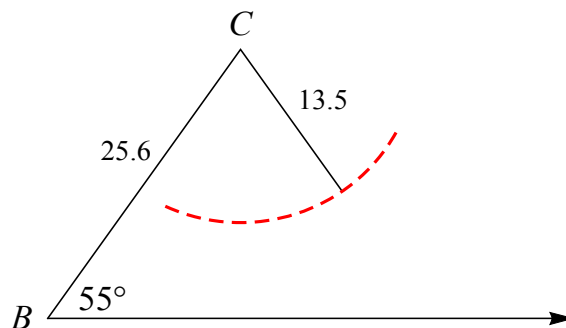

EXAMPLE 9

Solve triangle ABC , if $\angle B = 57^\circ$, $a = 27$ and $b = 23$.

$\angle A =$	$\angle B = 57^\circ$	$\angle C =$
$a = 27$	$b = 23$	$c =$

Solution:

What happened here (geometrically)?

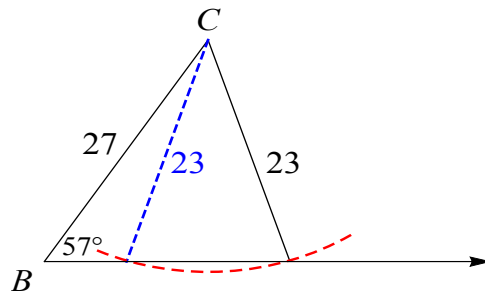

EXAMPLE 10

Solve triangle ABC , if $\angle A = 53.13^\circ$, $c = 20$ and $a = 16$.

Solution: First, draw a picture:

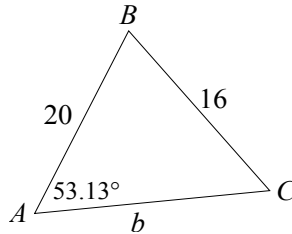

Next, find $\angle C$ using the Law of Sines:

$$\begin{aligned}\frac{\sin C}{20} &= \frac{\sin 53.13^\circ}{16} \\ \frac{\sin C}{20} &= \frac{.8}{16} \\ 16 \sin C &= (.8)20 = 16 \\ \sin C &= 1 \\ C &= \end{aligned}$$

Notice that this time, you only get one value of C !

So there is only one triangle, which after some more work, ends up being

$\angle A = 53.13^\circ$	$\angle B = 36.87^\circ$	$\angle C = 90^\circ$
$a = 16$	$b = 12$	$c = 20$

What happened here (geometrically)?

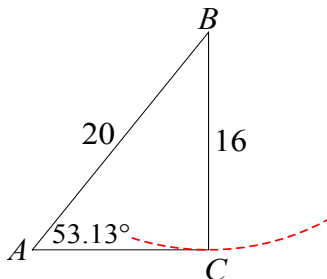

EXAMPLE 11

Solve triangle ABC , if $\angle A = 50^\circ$, $c = 15$ and $a = 20$.

Solution: First, draw a picture:

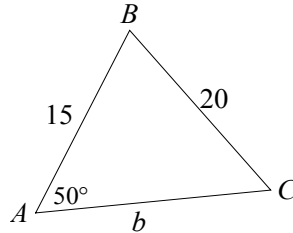

Next, find $\angle C$ using the Law of Sines:

$$\begin{aligned}\frac{\sin C}{15} &= \frac{\sin 50^\circ}{20} \\ \frac{\sin C}{15} &= \frac{.766}{20} \\ 20 \sin C &= (.766)15 = 11.325 \\ \sin C &= .5745 \\ C &= \arcsin .5745 \\ C &= 35.1^\circ \text{ and } C' = 180^\circ - 35.1^\circ = 144.9^\circ\end{aligned}$$

The situation where $C = 35.1^\circ$ works out to the following triangle:

$\angle A = 50^\circ$	$\angle B = 94.9^\circ$	$\angle C = 35.1^\circ$
$a = 20$	$b = 26.01$	$c = 15$

But the situation where $C' = 144.9^\circ$ is impossible, because in this case

$$B' = 180^\circ - A - C' = 180^\circ - 50^\circ - 144.9^\circ = -14.9^\circ.$$

Since $\angle B'$ can't be negative, that means there is only one triangle.

The geometric picture:

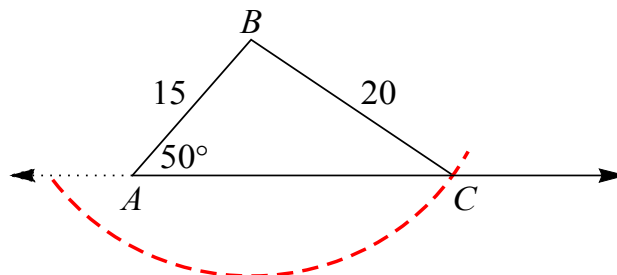

4.2 Law of Cosines

MOTIVATION

Suppose you know side lengths a and b and angle C of triangle ABC . Notice that the Law of Sines doesn't work here:

$$\frac{\sin A}{a} = \frac{\sin B}{b} = \frac{\sin C}{c}$$

So to solve arbitrary triangles, we need another law in addition to the Law of Sines. Here is that law:

Theorem 4.3 (Law of Cosines) *In any triangle with vertices labelled A , B and C and respective sides labelled a , b and c ,*

$$\begin{aligned}c^2 &= a^2 + b^2 - 2ab \cos C \\b^2 &= a^2 + c^2 - 2ac \cos B \\a^2 &= b^2 + c^2 - 2bc \cos A\end{aligned}$$

SOME INTUITION AS TO WHERE THIS COMES FROM

Way back in Chapter 2, we learned that for triangle ABC ,

$$c^2 = a^2 + b^2 \iff \angle C \text{ is a right angle}$$

$$c^2 < a^2 + b^2 \iff \angle C \text{ is } \underline{\hspace{2cm}}$$

$$c^2 > a^2 + b^2 \iff \angle C \text{ is } \underline{\hspace{2cm}}$$

Notice that in all three situations,

$$c^2 = a^2 + b^2 - (\text{something positive}) \cos C.$$

It turns out, after some work, that the something positive is $2ab$.

In other words, we think of the $-2ab \cos C$ term in the Law of Cosines as a “correction term” that fixes the Pythagorean Theorem when the triangle isn't a right triangle.

Law of Cosines Situation # 1: SSS

In this situation, you know all three side lengths of the triangle.

EXAMPLE 16

Solve triangle ABC , if $a = 14$, $b = 22$ and $c = 27$.

$\angle A =$	$\angle B =$	$\angle C =$
$a = 14$	$b = 22$	$c = 27$

Note: With the Law of Cosines, there is never a situation where you can get two triangles. But you might get no possible triangle:

EXAMPLE 17

Solve triangle ABC , if $a = 6.3$, $b = 18.5$ and $c = 25.3$.

$\angle A =$	$\angle B =$	$\angle C =$
$a = 6.3$	$b = 18.5$	$c = 25.3$

Solution:

$$\begin{aligned}
 a^2 &= b^2 + c^2 - 2bc \cos A \\
 6.3^2 &= 18.5^2 + 25.3^2 - 2(18.5)(25.3) \cos A \\
 39.69 &= 342.25 + 640.09 - 936.1 \cos A \\
 39.69 &= 982.34 - 936.1 \cos A \\
 -942.65 &= -936.1 \cos A \\
 1.006 &= \cos A
 \end{aligned}$$

What went wrong here, geometrically?

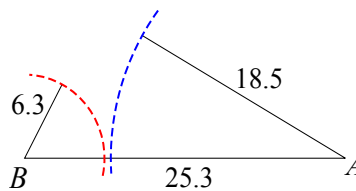

Theorem 4.4 (Triangle Inequality) If a , b and c are the three side lengths of a triangle, then

$$c \leq a + b \quad b \leq a + c \quad a \leq b + c.$$

Put another way, any side length of a triangle is less than or equal to the sum of the other two side lengths.

Law of Cosines Situation # 2: SAS

In this situation, you know two side lengths and the measure of the angle between those two sides.

EXAMPLE 18

A surveyor wants to find the distance between two points A and B on the opposite side of a lake. She goes to a third point on the side of the lake, and figures that her distance to A is 340 meters, and her distance to B is 385 meters. She also notices that the angle between her line of sight to A and her line of sight to B is 163.5° . What is the distance between A and B ?

EXAMPLE 19

Solve right triangle ABC , if $a = 28.5$ and $b = 22.3$.

$\angle A =$	$\angle B =$	$\angle C =$
$a = 28.5$	$b = 22.3$	$c =$

Solution:

Summary of procedure to solve triangles

Known information in triangle	Procedure for solving the triangle
SSS	Find one angle using the Law of Cosines. Then find a second angle using the Law of Cosines. Last, find the third angle (the angles add to 180°).
SAS	Find the third side length using the Law of Cosines. Then find a second angle using the Law of Cosines. Last, find the third angle (the angles add to 180°).
ASA / AAS / SAA	Find the third angle (the angles add to 180°). Then use the Law of Sines to find the remaining sides.
SSA / ASS	Find a second angle using the Law of Sines. WARNING: ambiguous case (there may be zero, one or two triangles possible) For each second angle you find, compute the third angle (the angles add to 180°). <i>If the third angle is negative, throw out that triangle, leaving you with only one triangle.</i> Last, for each second angle, find the remaining side using either the Law of Sines or the Law of Cosines.
AAA	This is not a doable problem. The triangle could be any size.

4.3 SOHCAHTOA

Consider this generic right triangle:

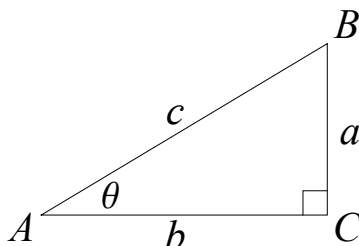

Question 1: In terms of θ , what is $\angle B$?

Question 2: Based on the answer to question 1, what relationships hold between the cosines/sines of angles A and B ?

$$\cos A = \cos \theta =$$

$$\sin A = \sin \theta =$$

Now, from the Law of Sines, we see

$$\frac{\sin A}{a} = \frac{\sin C}{c} \quad \text{and} \quad \frac{\sin B}{b} = \frac{\sin C}{c}$$

On the previous page, we showed:

Theorem 4.5 (SOHCAHTOA) Let θ be an angle between 0° and 90° . Put θ in a **right** triangle:

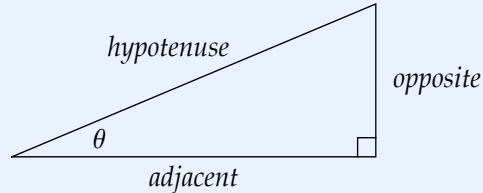

Then:

$$\sin \theta = \frac{\text{opposite}}{\text{hypotenuse}} \quad \cos \theta = \frac{\text{adjacent}}{\text{hypotenuse}} \quad \tan \theta = \frac{\text{opposite}}{\text{adjacent}}$$

WARNING: These ideas only work for angles between 0° and 90° , so they aren't that useful in the grand scheme of things.

To help remember which fraction goes with which trig function, use the mnemonic device **SOHCAHTOA**:

SOH CAH TOA

One area where these can be helpful is to help you quickly solve **right** triangles, without having to use the Laws of Sines or Cosines:

EXAMPLE 20

a) Suppose ABC is a right triangle. If $a = 9$ and $c = 14$, what is $\angle A$?

b) Suppose PQR is a right triangle. If $\angle P = 19.5^\circ$ and $q = 25$, what is p ?

EXAMPLE 21

Suppose ABC is a right triangle with sides of lengths a , b and c (where angle C is the right angle). If $a = 6$ and $b = 8$, find the sine and cosine of angle A , and find the sine and cosine of angle B .

EXAMPLE 22

Find the exact values of $\sin \theta$, $\cos \theta$ and $\tan \theta$:

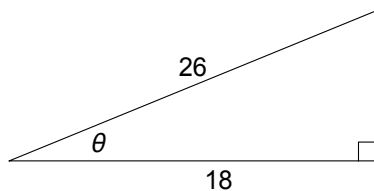

$$\sin \theta =$$

$$\cos \theta =$$

$$\tan \theta =$$

4.4 Interpreting dot products

RECALL

When we introduced vectors in Chapter 2, I told you about an operation called *dot product*:

$$\langle a, b \rangle \cdot \langle c, d \rangle = ac + bd$$

IMPORTANT: the dot product of two vectors is a **scalar**.

EXAMPLE: $\langle 2, 5 \rangle \cdot \langle 4, 8 \rangle = 2(4) + 5(8) = 8 + 40 = \boxed{48}$.

QUESTION

Why do we care about dot product?

Let $\mathbf{v} = \langle a, b \rangle$. Then

$$\mathbf{v} \cdot \mathbf{v} =$$

Theorem 4.6 (Magnitude formula with dot products) *Let \mathbf{v} be any vector. Then*

$$|\mathbf{v}| = \sqrt{\mathbf{v} \cdot \mathbf{v}} \quad \text{and} \quad \mathbf{v} \cdot \mathbf{v} = |\mathbf{v}|^2.$$

More generally, the last formula says “*anything · itself = |that thing|²*”.

Now, let’s introduce addition into the picture:

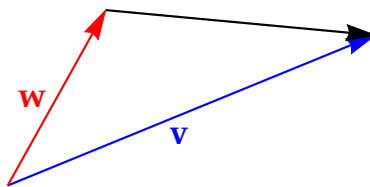

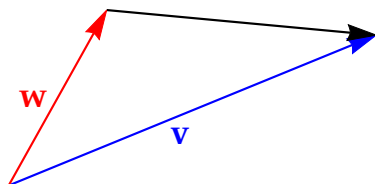

We are going to compute $|\mathbf{v} - \mathbf{w}|^2$ two different ways, and something interesting will happen:

Method 1: From the theorem on the previous page applied to $\mathbf{v} - \mathbf{w}$,

$$\begin{aligned} |\mathbf{v} - \mathbf{w}|^2 &= (\mathbf{v} - \mathbf{w}) \cdot (\mathbf{v} - \mathbf{w}) \\ &= \mathbf{v} \cdot \mathbf{v} - \mathbf{v} \cdot \mathbf{w} - \mathbf{w} \cdot \mathbf{v} + \mathbf{w} \cdot \mathbf{w} \\ &= |\mathbf{v}|^2 - \mathbf{v} \cdot \mathbf{w} - \mathbf{v} \cdot \mathbf{w} + |\mathbf{w}|^2 \\ &= |\mathbf{v}|^2 - 2\mathbf{v} \cdot \mathbf{w} + |\mathbf{w}|^2 \end{aligned}$$

Method 2: From the Law of Cosines,

$$\begin{aligned} c^2 &= a^2 + b^2 - 2ab \cos C \\ |\mathbf{v} - \mathbf{w}|^2 &= |\mathbf{v}|^2 + |\mathbf{w}|^2 - 2|\mathbf{v}||\mathbf{w}|\cos \theta \end{aligned}$$

On the previous page, we showed:

Theorem 4.7 (Angle formula with dot products) Let \mathbf{v} and \mathbf{w} be two vectors and let θ be the angle between them. Then

$$\mathbf{v} \cdot \mathbf{w} = |\mathbf{v}| |\mathbf{w}| \cos \theta.$$

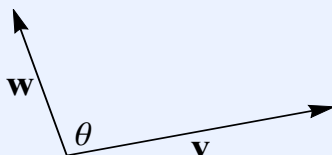

EXAMPLE 23

Compute the angle between the vectors $\mathbf{v} = \langle 2, 7 \rangle$ and $\mathbf{w} = \langle -3, 5 \rangle$. Also, draw a picture to illustrate what you have computed.

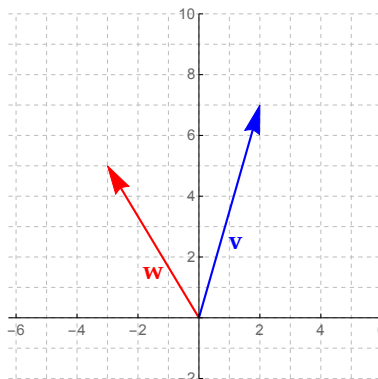

Orthogonality

A major use of dot product is that it can quickly tell you whether the angle between two vectors is acute, right or obtuse:

$$\mathbf{v} \cdot \mathbf{w} = |\mathbf{v}| |\mathbf{w}| \cos \theta$$

Theorem 4.8 Let \mathbf{v} and \mathbf{w} be vectors and let θ be the angle between them. Then:

$$\mathbf{v} \cdot \mathbf{w} > 0 \iff \theta \text{ is acute}$$

$$\mathbf{v} \cdot \mathbf{w} < 0 \iff \theta \text{ is obtuse}$$

$$\mathbf{v} \cdot \mathbf{w} = 0 \iff \theta = 90^\circ, \text{ i.e. } \mathbf{v} \perp \mathbf{w}.$$

In the last situation, we say \mathbf{v} and \mathbf{w} are **orthogonal** (a.k.a. **perpendicular**).

EXAMPLE 24

Let $\mathbf{u} = \langle -4, 14 \rangle$, let $\mathbf{v} = \langle 5, -3 \rangle$ and let $\mathbf{w} = \langle 7, 2 \rangle$. For each pair of vectors, determine if the angle between them is acute, obtuse or right. Then, state which two of \mathbf{u} , \mathbf{v} and/or \mathbf{w} are orthogonal.

Solution: Compute dot products:

$$\mathbf{u} \cdot \mathbf{v} = \quad \Rightarrow \text{angle between } \mathbf{u} \text{ and } \mathbf{v} \text{ is}$$

$$\mathbf{u} \cdot \mathbf{w} = \quad \Rightarrow \text{angle between } \mathbf{u} \text{ and } \mathbf{w} \text{ is}$$

$$\mathbf{v} \cdot \mathbf{w} = 5(7) + (-3)2 = 35 - 6 = 29 > 0 \quad \Rightarrow \text{angle between } \mathbf{v} \text{ and } \mathbf{w} \text{ is}$$

EXAMPLE 25

Let $\mathbf{v} = \langle -3, 8 \rangle$, and let $\mathbf{w} = \langle 16, y \rangle$. If $\mathbf{v} \perp \mathbf{w}$, then find y .

4.5 Area formulas for triangles

Theorem 4.9 (Traditional area formula) *If a triangle has base b and height h , then the area of the triangle is*

$$A = \frac{1}{2}bh.$$

EXAMPLE 26

Compute the area of this triangle:

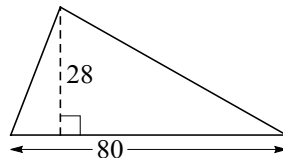

The drawback of the traditional formula is that the h is often unknown. Usually what you know about a triangle is its side lengths and angle measures, which don't directly tell you what h is. Here's a better version of the same formula for the area of a triangle, involving only side lengths and angle measures:

Theorem 4.10 (SAS area formula) *If a triangle has two sides a and b , with angle C between sides a and b , then the area of the triangle is*

$$A = \frac{1}{2}ab \sin C.$$

EXAMPLE 27

Compute the exact area (no decimals) of this triangle:

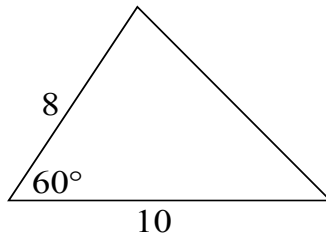

EXAMPLE 28

Compute (a decimal approximation of) the area of this triangle:

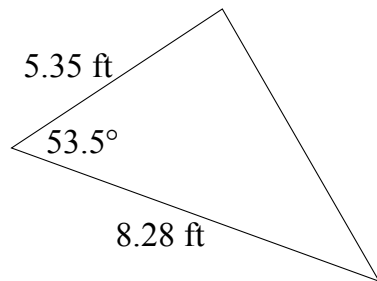

Solution:

$$\begin{aligned} A &= \frac{1}{2}ab \sin C \\ &= \frac{1}{2}(5.35)(8.28) \sin 53.5^\circ \\ &= \boxed{17.805 \text{ sq ft}} \end{aligned}$$

EXAMPLE 29

Compute (a decimal approximation of) the area of triangle ABC , if $a = 25.7$, $b = 18.3$, $\angle A = 102^\circ$ and $\angle B = 55^\circ$.

The drawback of the SAS area formula is that you have to know an angle measure. Often all you know are the lengths of the sides of a triangle. In this case, you can use this formula:

Theorem 4.11 (Heron's formula) Suppose that a triangle has side lengths a , b and c . Define the **semiperimeter** of the triangle to be half of its perimeter, i.e.

$$s = \frac{a + b + c}{2}.$$

Then the area of the triangle is

$$A = \sqrt{s(s-a)(s-b)(s-c)}.$$

WHY IS HERON'S FORMULA TRUE?

First, from rearranging the Law of Cosines, we get

$$\cos C = \frac{a^2 + b^2 - c^2}{2ab}.$$

Second, from the Pythagorean Identity $\cos^2 C + \sin^2 C = 1$, we get

$$\sin C = \sqrt{1 - \cos^2 C}.$$

Take the area formula $Area = \frac{1}{2}ab \sin C$, plug in the formula above for $\sin C$ to get

$$Area = \frac{1}{2}ab\sqrt{1 - \cos^2 C}.$$

Then replace $\cos C$ with the top formula above to get

$$Area = \frac{1}{2}ab\sqrt{1 - \left(\frac{a^2 + b^2 - c^2}{2ab}\right)^2}.$$

Do two pages of algebra on the right-hand side; eventually this simplifies to Heron's formula.

EXAMPLE 30

Compute the area of the following triangle:

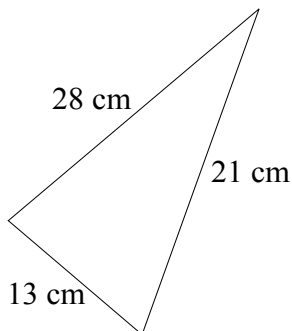

EXAMPLE 29

Compute the area of triangle PQR if $p = 9$, $q = 10$ and $r = 17$.

Solution: First, find the semiperimeter s :

$$s = \frac{p + q + r}{2} = \frac{9 + 10 + 17}{2} = \frac{36}{2} = 18.$$

Next, use Heron's formula to find the area:

$$\begin{aligned} A &= \sqrt{s(s-p)(s-q)(s-r)} \\ &= \sqrt{18(18-9)(18-10)(18-17)} \\ &= \sqrt{18(9)(8)(1)} \\ &= \sqrt{1296} \\ &= \boxed{36}. \end{aligned}$$

EXAMPLE 31

A wealthy rancher owns a triangular plot of land in Wyoming. He measures the lengths of the sides of his property as 19.5 mi, 22.0 mi and 25.7 mi. How many square miles of land does he own?

Solution: First, find the semiperimeter s :

$$s = \frac{p + q + r}{2} = \frac{19.5 + 22.0 + 25.7}{2} = \frac{67.2}{2} = 33.6.$$

Next, use Heron's formula to find the area:

$$\begin{aligned} A &= \sqrt{s(s-p)(s-q)(s-r)} \\ &= \sqrt{33.6(33.6-19.5)(33.6-22.0)(33.6-25.7)} \\ &= \sqrt{33.6(14.1)(11.6)(7.9)} \\ &= \sqrt{43415.37} \\ &= \boxed{208.36 \text{ sq mi}}. \end{aligned}$$

Chapter 5

Oscillations and trig graphs

5.1 Review: what is a graph?

The **graph** of a function f is a picture of the points (x, y) in the xy -plane for which $y = f(x)$.

MOTIVATING EXAMPLE

Sketch the graph of $y = x^2$ (also known as $f(x) = x^2$)

x	$y = f(x) = x^2$
-2	
-1	
0	
1	
2	
3	

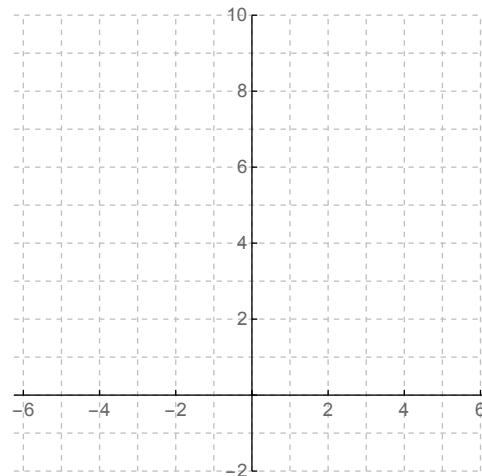

A crude picture of the graph of $y = x^2$:

A crude picture like this one is usually enough in the context of application problems, because the crude picture contains all the “essential” properties of the graph:

- it is a curve that is symmetric about the y -axis,
- it turns at $(0, 0)$,
- it is a parabola,
- etc.

OUR GOAL

We want to quickly sketch crude graphs of (relatively simple) functions involving sine and cosine (and to a lesser extent, tangent). We want to be able to do this without using a calculator, and in general, more quickly than we could if we used a calculator.

If the function isn’t “relatively simple”, then it isn’t terribly useful to learn how to graph it, given that calculators and computers draw accurate graphs of complicated functions.

5.2 Graphs of $\sin x$ and $\cos x$

Let's start with the graph of $y = \sin x$.

NOTE: in the context of graphing, x is **always assumed to be in radians**.

x	$y = \sin x$
0	
$\frac{\pi}{6}$	
$\frac{\pi}{4}$	
$\frac{\pi}{3}$	
$\frac{\pi}{2}$	
π	
$\frac{3\pi}{2}$	
2π	

Plot these points and connect them with a curve:

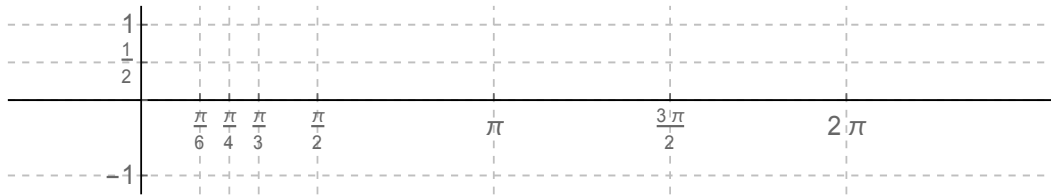

This is the graph of $y = \sin x$ for x between 0 and 2π . What happens for other x ?

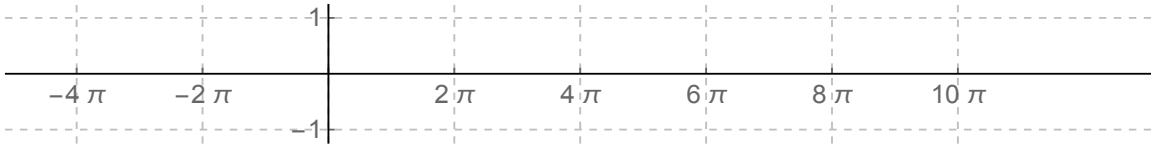

Definition 5.1 The **period** of a function is the distance in the x -direction it takes for the graph of the function to start repeating itself. Algebraically, the period is the smallest positive number T such that $f(x + T) = f(x)$ for all x .

EXAMPLES

- The period of $y = \sin x$ is 2π .
- The period of $y = \cos x$ is 2π (because $\cos(x + 2\pi) = \cos x$).
- There is no period of $y = x^2$ (because the graph doesn't repeat itself).

To summarize, here is a picture of the graph of $y = \sin x$:

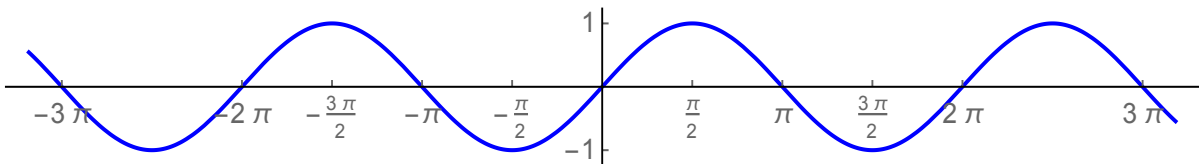

The crude picture you need to be able to draw is this:

This crude picture shows the following important information about $y = \sin x$:

- the graph goes through $(0, 0)$;
- one complete period of the graph is 2π ;
- the graph goes as far up as 1 and as far down as -1 ;
- the general shape of the graph is a wave;
- the graph is *smooth* (no sharp corners);
- from the point $(0, 0)$, the graph heads upward as you move to the right.

5.2. Graphs of $\sin x$ and $\cos x$

Now let's do $y = \cos x$. As with $\sin x$, the graph has period 2π so we only need to know what the shape looks like from $x = 0$ to $x = 2\pi$:

x	$y = \cos x$
0	
$\frac{\pi}{6}$	
$\frac{\pi}{4}$	
$\frac{\pi}{3}$	
$\frac{\pi}{2}$	
π	-1
$\frac{3\pi}{2}$	0
2π	1

Here is the graph of $y = \cos x$ for x between 0 and 2π :

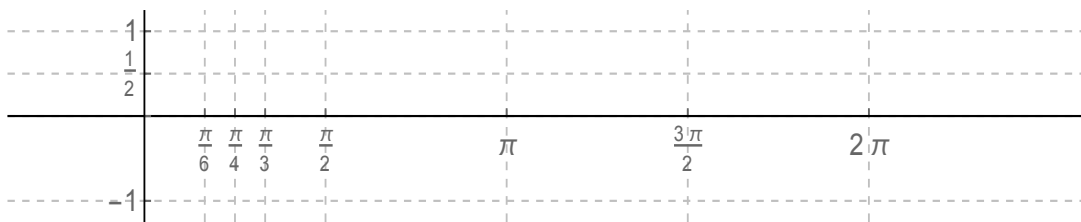

and here is the entire graph of $y = \cos x$:

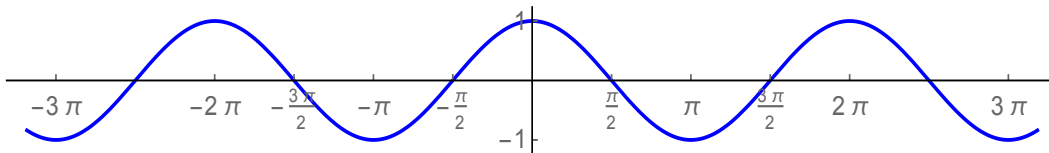

The crude picture you need to be able to draw is this:

This crude picture shows the following important information about $y = \cos x$:

- the graph goes through $(0, 1)$;
- one complete period of the graph is 2π ;
- the graph goes as far up as 1 and as far down as -1 ;
- the general shape of the graph is a wave;
- the graph is smooth;
- from the point $(0, 1)$, the graph heads downward as you move to the right.

5.3 Transformations on sine and cosine

IDEA

Start with a function that has some formula. A **transformation** of that function refers to a function whose formula comes from the first function by including some extra constant(s) somewhere.

EXAMPLES

- Transformations of the function $y = x^2$ include

$$y = x^2 + 2 \quad y = \frac{-1}{4}x^2 \quad y = (x - 2)^2 \quad y = (3x)^2 - 1 \quad \text{etc.}$$

- Transformations of the function $y = \sin x$ include

$$y = 2 \sin x \quad y = \sin(x + 3) \quad y = \sin 6x - 5 \quad y = \frac{2}{3} \sin 2x - 1 \quad \text{etc.}$$

- Transformations of the function $y = \cos x$ include

$$y = \frac{3}{4} \cos x \quad y = -\cos(x - \pi) \quad y = \cos 7x - 3 \quad y = -8 \cos 4x \quad \text{etc.}$$

Definition 5.2 Any function which is a transformation of $y = \sin x$ or $y = \cos x$ is called a **sinusoidal function** (its graph is called a **sinusoidal graph**).

This section is about how to (quickly and crudely) graph sinusoidal functions.

Sinusoidal graphs are important because they model *oscillations* (quantities that go back and forth or up and down with regularity over time). Real-world oscillations include ocean waves, light and sound waves, harmonics, alternating currents, pulses, radiation, etc.

We also want to be able to go from a picture of a graph to a formula for a function that has that graph, so that we can appropriately model oscillating behavior.

How to graph $y = \sin x + D$ and $y = \cos x + D$

MOTIVATING EXAMPLE

Graph $y = \sin x + 3$.

x	$\sin x$	point on $y = \sin x$	$\sin x + 3$	point on $y = \sin x + 3$
0	0	$(0, 0)$		
$\frac{\pi}{6}$	$\frac{1}{2} = .5$	$(\frac{\pi}{6}, .5)$		
$\frac{\pi}{4}$	$\frac{\sqrt{2}}{2} \approx .707$	$(\frac{\pi}{4}, .707)$		
$\frac{\pi}{2}$	1	$(\frac{\pi}{2}, 1)$		
π	0	$(\pi, 0)$		
$\frac{3\pi}{2}$	-1	$(\frac{3\pi}{2}, -1)$		
2π	0	$(2\pi, 0)$		

5.3. Transformations on sine and cosine

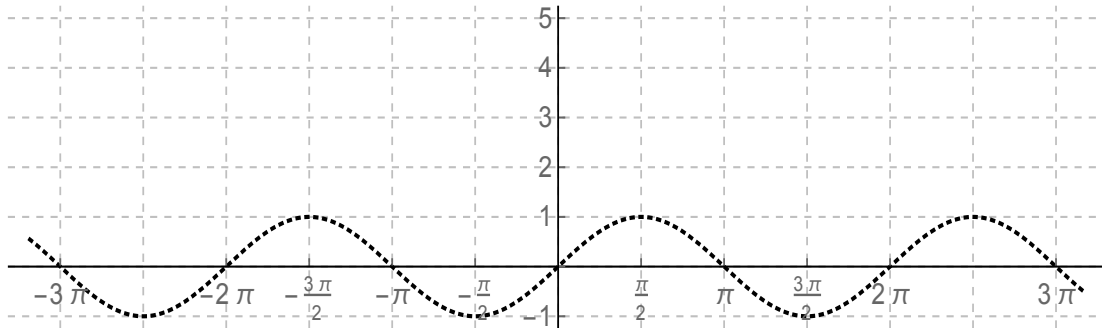

Theorem 5.3 (Vertical shift) The graph of $y = \sin x + D$ is the graph of $y = \sin x$, shifted upward/downward by D units:

- The graph is shifted up if $D > 0$.
- The graph is shifted down if $D < 0$.

Similarly, the graph of $y = \cos x + D$ is the graph of $y = \cos x$, shifted vertically by D units (up if $D > 0$ and down if $D < 0$).

EXAMPLE 1

a) Graph $y = \sin x - 2$.

b) Graph $f(x) = \cos x + 1$.

c) What equation has the graph given below?

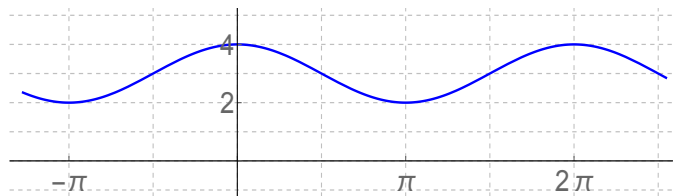

d) What equation has the graph given below?

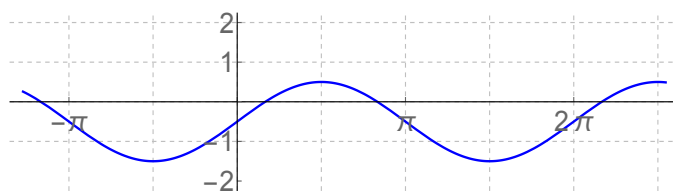

How to graph $y = A \sin x$ and $y = A \cos x$

MOTIVATING EXAMPLE

Graph $y = 3 \sin x$.

x	point on $\sin x$	$y = \sin x$	$3 \sin x$	point on $y = 3 \sin x$
0	0	$(0, 0)$		
$\frac{\pi}{6}$	$\frac{1}{2} = .5$	$(\frac{\pi}{6}, .5)$		
$\frac{\pi}{4}$	$\frac{\sqrt{2}}{2} \approx .707$	$(\frac{\pi}{4}, .707)$		
$\frac{\pi}{2}$	1	$(\frac{\pi}{2}, 1)$		
π	0	$(\pi, 0)$		
$\frac{3\pi}{2}$	-1	$(\frac{3\pi}{2}, -1)$		
2π	0	$(2\pi, 0)$		

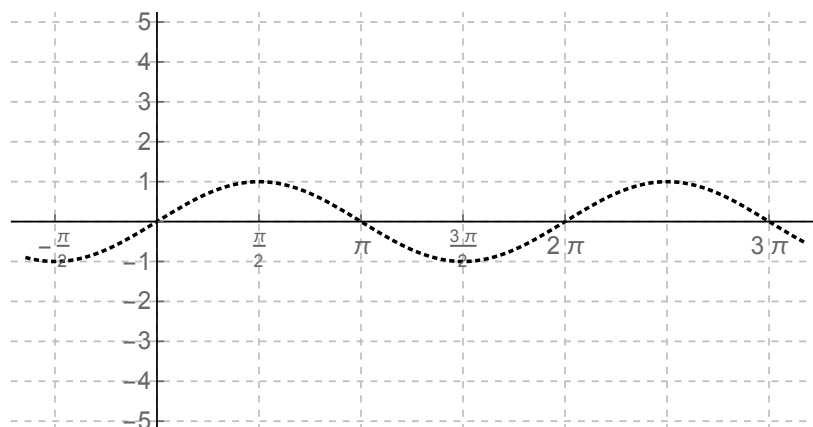

Theorem 5.4 (Vertical stretch) The graph of $y = A \sin x$ is the graph of $y = \sin x$, stretched upward/downward by a factor of A .

- If $|A| > 1$, the graph is stretched vertically.
- If $|A| < 1$, the graph is compressed vertically.
- If $A < 0$, the graph is flipped upside down.

$|A|$ is called the **amplitude** of $y = A \sin x$.

Similarly, the graph of $y = A \cos x$ is the graph of $y = \cos x$, stretched/compressed vertically in the same way. $|A|$ is called the **amplitude** of $y = A \cos x$.

EXAMPLE 2

a) Graph $y = -4 \sin x$.

b) Graph $f(x) = 5 \cos x$.

c) Graph $y = \frac{1}{2} \cos x$.

d) What equation has the graph given below at left?

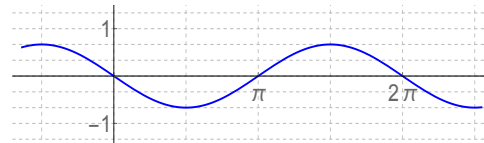
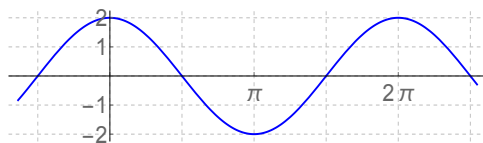

e) What equation has the graph given above at right?

How to graph $y = \sin(x - C)$ and $y = \cos(x - C)$

Theorem 5.5 (Horizontal shift) The graph of $y = \sin(x - C)$ is the graph of $y = \sin x$, *shifted leftward/rightward* by C units.

- The graph is *shifted rightward* if $C > 0$.
- The graph is *shifted leftward* if $C < 0$.

Similarly, the graph of $y = \cos(x - C)$ is the graph of $y = \cos x$, *shifted leftward/rightward* by C units in the same way (right if $C > 0$ and left if $C < 0$).

EXAMPLE 3

a) Graph $y = \sin(x - \frac{\pi}{2})$.

b) Graph $y = \cos(x + 2)$.

c) Graph $f(x) = \sin(x + \frac{3\pi}{4})$.

d) Write an equation with \sin in it that has the graph given below.

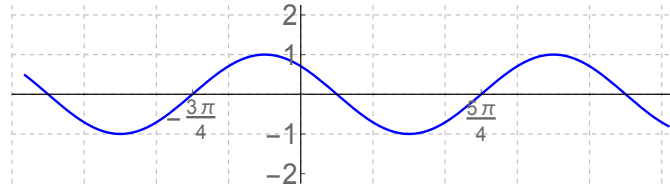

e) Write an equation with \cos in it that has the graph given above.

f) What identity can you conclude from your answers to (d) and (e)?

Graphing $y = \sin Bx$ and $y = \cos Bx$

Theorem 5.6 (Horizontal stretch) The graph of $y = \sin Bx$ is the graph of $y = \sin x$, stretched/compressed horizontally so that its period is $\frac{2\pi}{B}$.

Similarly, the graph of $y = \cos Bx$ is the graph of $y = \cos x$, stretched/compressed horizontally so that its period is $\frac{2\pi}{B}$.

EXAMPLE 4

a) Graph $f(x) = \sin 4x$.

b) Graph $f(x) = \cos \pi x$.

c) Graph $y = \sin \frac{x}{6}$.

d) Write an equation that has the graph given below.

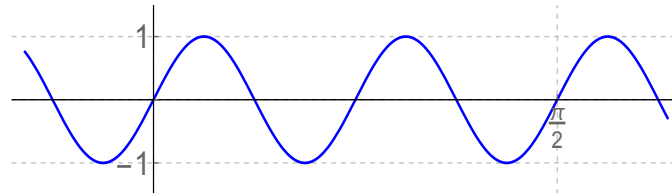

e) Write an equation that has the graph given below.

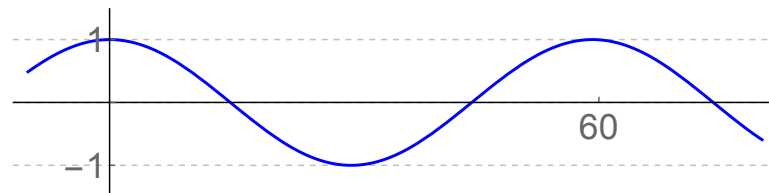

Putting all this together

What if you have a function with more than one kind of transformation?

Procedure to draw a sinusoidal graph

1. Write the function in the standard form:

$$y = A \sin(B(x - C)) + D \quad \text{or} \quad y = A \cos(B(x - C)) + D$$

Once in this form:

- A is the vertical stretch (a.k.a. the amplitude),
 - B is the horizontal stretch,
 - C is the horizontal shift, and
 - D is the vertical shift.
2. Draw dashed “crosshairs” at the point (C, D) . (This accounts for the horizontal and vertical shift.)
 3. From the vertical crosshair, go **up and down A units** and mark the y -coordinates of those heights. (This tells you how far up and down the graph should go.)

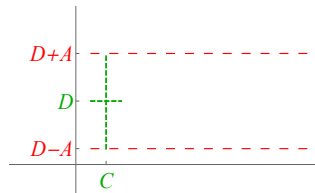

4. Starting in the appropriate place, **draw one period** of the graph.
5. Then, **mark where the period finished**. This should be at $x = C + \frac{2\pi}{B}$, since the period is $T = \frac{2\pi}{B}$.

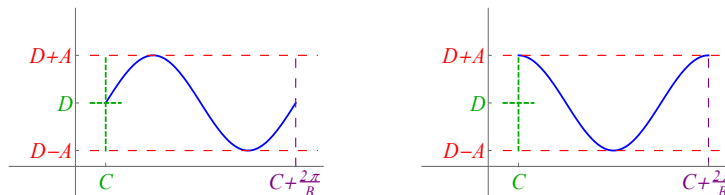

6. If your picture is too messy, erase any crosshairs and the horizontal and/or vertical lines you drew (but not the numbers you marked on the x - and y -axes).

5.3. Transformations on sine and cosine

If you carry out these steps, you'll get a graph like one of these:

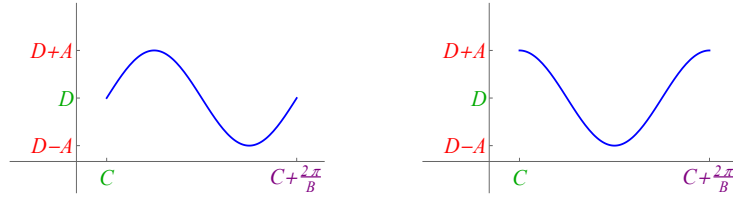

The rest of the graph just repeats itself periodically, but you generally don't have to draw that.

EXAMPLE 5

Sketch a graph of each function:

a) $y = 4 \cos 2x$

b) $f(x) = \sin\left(x - \frac{\pi}{2}\right) - 3$

Solution: This graph has a horizontal shift of $\frac{\pi}{2}$ units to the right, and a vertical shift of 3 units down. The amplitude is 1 and the period is 2π (no stretching in either direction). So the graph looks like this:

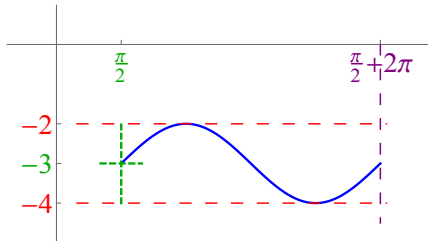

c) $y = -\cos\frac{x}{4} + 5$

EXAMPLE 6

For each graph, write an equation that has that graph:

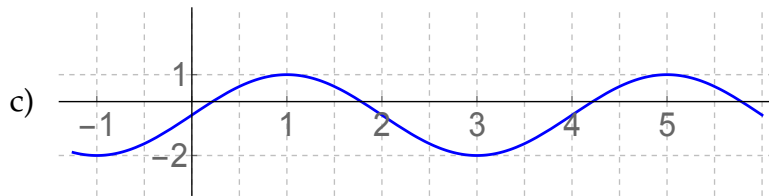
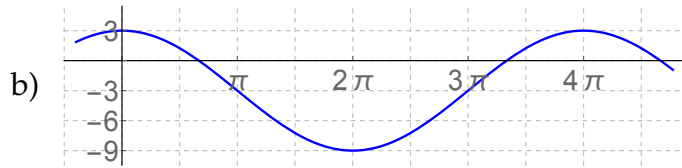
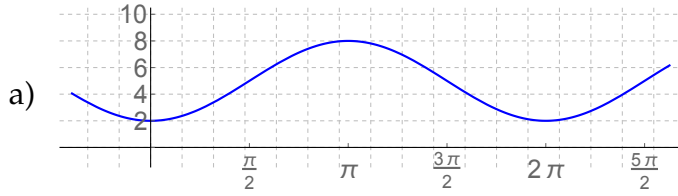

EXAMPLE 7

For each sinusoidal function graphed below, compute the (exact) value of y when $x = 20$.

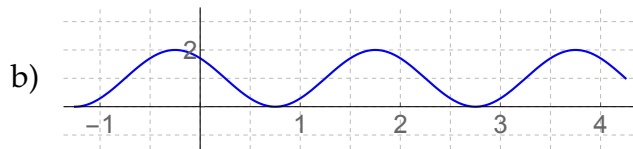
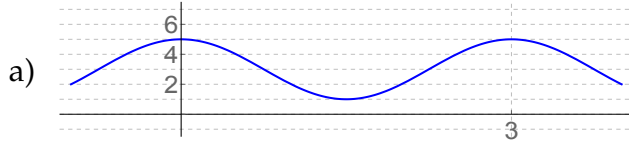

EXAMPLE 8 (FROM CHAPTER 2)

From the graph below, write an equation which gives the water depth in terms of the position, and use your equation to predict the water depth at position 300:

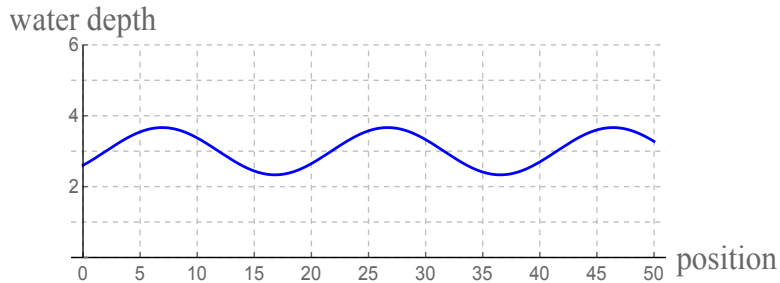

EXAMPLE 9

The graph below describes the amount of current flowing through a circuit at time t . Write an equation giving the current in the circuit as a function of the time, and use your equation to determine the current at time 8.25.

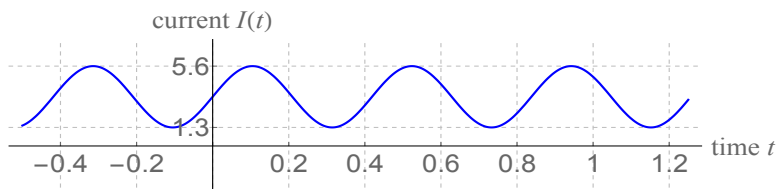
5.4 The graph of $y = \tan x$

We can write $y = \tan x = \frac{\sin x}{\cos x}$. This means:

- when $\sin x = 0$, $\tan x$

The values of x where this happens are

- when $\cos x = 0$, $\tan x$

The values of x where this happens are

5.4. The graph of $y = \tan x$

We can fill in the rest of the graph of $y = \tan x$ by making a table of values:

x	$y = \tan x$
0	0
$\frac{\pi}{6}$	$\frac{1}{\sqrt{3}} \approx .577$
$\frac{\pi}{4}$	1
$\frac{\pi}{3}$	$\sqrt{3} \approx 1.73$
$\frac{2\pi}{3}$	$-\sqrt{3} \approx -1.73$
$\frac{3\pi}{4}$	-1
$\frac{5\pi}{6}$	$-\frac{1}{\sqrt{3}} \approx -.577$

Putting this together, we get the graph of $y = \tan x$ shown below:

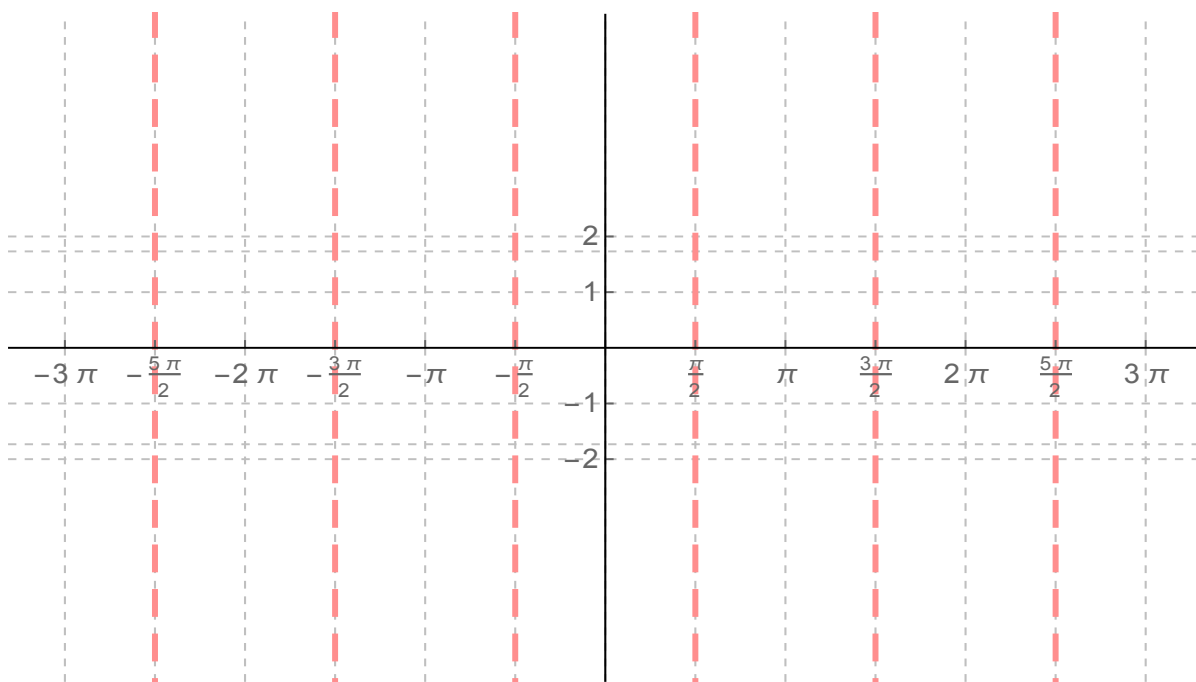

Chapter 6

Secant, cosecant and cotangent

6.1 Definitions

So far in this course, we have extensively studied three trigonometric functions: cosine, sine and tangent.

There are three other trig functions, which are the reciprocals of the functions we have already defined:

Definition 6.1 *Let θ be a number or an angle. Define the **secant, cosecant and cotangent** of θ to be, respectively,*

$$\sec \theta = \frac{1}{\cos \theta} \quad \csc \theta = \frac{1}{\sin \theta} \quad \cot \theta = \frac{1}{\tan \theta}$$

REMARK

You can solve any trig problem with only sine, cosine and tangent.

Examples:

- solving triangles needs only the Law of Sines and the Law of Cosines;
- the SAS area formula uses only sine;
- vector conversion formulas use sin, cos and arctan;
- etc.

These three new trig functions are here mainly to streamline computations in future settings (especially calculus applications).

The most important thing to know about \sec , \csc and \cot is that they are reciprocals of the trig functions we have already studied:

Theorem 6.2 (Reciprocal identities)

$$\begin{array}{ll} \sec \theta = \frac{1}{\cos \theta} & \cos \theta = \frac{1}{\sec \theta} \\ \csc \theta = \frac{1}{\sin \theta} & \sin \theta = \frac{1}{\csc \theta} \\ \cot \theta = \frac{1}{\tan \theta} & \tan \theta = \frac{1}{\cot \theta} \end{array}$$

EXAMPLE 1

1. Suppose $\tan \theta = 3$. What is $\cot \theta$?
2. Suppose $\sin \theta = \frac{1}{4}$. What trig function of θ must equal 4?
3. Suppose $\sec \theta = 2.587$. Compute $\cos \theta$.

Solution: $\cos \theta = \frac{1}{\sec \theta} = \frac{1}{2.587} = \boxed{.3865}$.

4. Suppose $\cot \theta = \frac{4}{7}$. Compute $\tan \theta$.

Solution: $\tan \theta = \frac{1}{\cot \theta} = \frac{1}{\frac{4}{7}} = \boxed{\frac{7}{4}}$.

5. Suppose $\csc \theta = 5.35$ and $\cos \theta < 0$. Compute $\cos \theta$.

Evaluating trig functions on a calculator

Your calculator (probably) has $\boxed{\text{COS}}$, $\boxed{\text{SIN}}$ and $\boxed{\text{TAN}}$ buttons, but probably does not have $\boxed{\text{SEC}}$, $\boxed{\text{CSC}}$ or $\boxed{\text{COT}}$ buttons. To evaluate secants, cosecants and/or cotangents, we use the reciprocal identities given on the previous page:

EXAMPLE 2

Evaluate (a decimal approximation of) each quantity using a calculator:

a) $\csc 117^\circ$

b) $\tan 219^\circ$

Solution: From a calculator, $\tan 219^\circ = \boxed{.8098}$.

c) $\cot 76.5^\circ$

Solution: From a calculator, $\tan 76.5^\circ = 4.1653$.

$$\text{Therefore } \cot 76.5^\circ = \frac{1}{\tan 76.5^\circ} = \frac{1}{4.1653} = \boxed{.24}.$$

d) $\sec 283^\circ$

Solution: From a calculator, $\cos 283^\circ = .224951$.

$$\text{Therefore } \sec 283^\circ = \frac{1}{\cos 283^\circ} = \frac{1}{.224951} = \boxed{4.44541}.$$

e) $\csc(44^\circ + 87^\circ)$

f) $\sec^2(-73.5^\circ)$

g) $\cot 118^\circ - 2 \sin 36^\circ$

Unit circle definitions

Theorem 6.3 (Unit circle definition of the trig functions) If (x, y) is the point on the unit circle at angle θ , then:

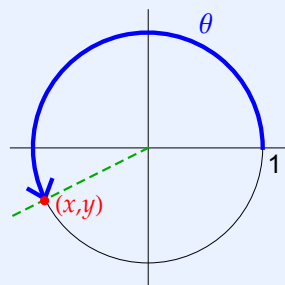

$$\begin{aligned} \sin \theta &= \sin(\theta) = y & \csc \theta &= \csc(\theta) = \frac{1}{y} \\ \cos \theta &= \cos(\theta) = x & \sec \theta &= \sec(\theta) = \frac{1}{x} \\ \tan \theta &= \tan(\theta) = & \cot \theta &= \cot(\theta) = \end{aligned}$$

Angle definitions

Theorem 6.4 (Angle definition of the trig functions) If (x, y) any point on the terminal side of angle θ when drawn in standard position, and if $r = \sqrt{x^2 + y^2}$, then:

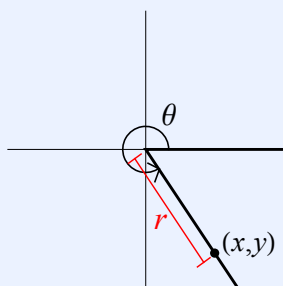

$$\begin{aligned} \sin \theta &= \sin(\theta) = \frac{y}{r} & \csc \theta &= \csc(\theta) = \\ \cos \theta &= \cos(\theta) = \frac{x}{r} & \sec \theta &= \sec(\theta) = \\ \tan \theta &= \tan(\theta) = & \cot \theta &= \cot(\theta) = \end{aligned}$$

EXAMPLE 3

Suppose that the point $(-2, 7)$ is on the terminal side of an angle θ when drawn in standard position. Determine the values of all six trig functions of θ .

Theorem 6.5 (Quotient Identities)

$$\tan \theta = \frac{\sin \theta}{\cos \theta} \qquad \cot \theta = \frac{\cos \theta}{\sin \theta}$$

EXAMPLE 4

a) Suppose $\cot \theta = \frac{1}{3}$ and $\cos \theta = -\frac{1}{\sqrt{10}}$. Compute $\sin \theta$.

b) Suppose $\sin \theta = a$ and $\cos \theta = b$. Compute $\cot \theta$, in terms of a and/or b .

SOHCAHTOA definitions

Theorem 6.6 (Right triangle definition of the trig functions) Let $0 \leq \theta \leq 90^\circ$. Then, thinking of θ as an angle in a right triangle like this,

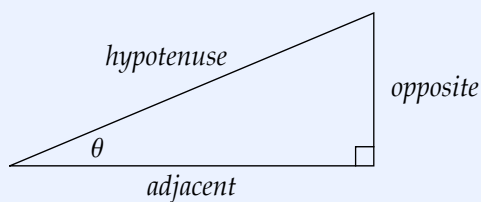

we have:

$$\text{SOH CAH TOA: } \sin \theta = \frac{\text{opp}}{\text{hyp}} \qquad \cos \theta = \frac{\text{adj}}{\text{hyp}} \qquad \tan \theta = \frac{\text{opp}}{\text{adj}}$$

$$\text{Reciprocals: } \csc \theta = \frac{\text{hyp}}{\text{opp}} \qquad \sec \theta = \frac{\text{hyp}}{\text{adj}} \qquad \cot \theta = \frac{\text{adj}}{\text{opp}}$$

EXAMPLE 5

Compute the values of all six trig functions of θ :

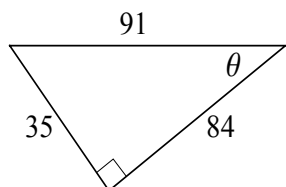

Solving diagrams with trig expressions

GOAL

Given a picture, we want to write an equation which gives some quantity (like a length, an angle, area, volume, or something else) in terms of other given information in the picture.

Often, the given information in the picture is either changing as time passes, or consists of unknown quantities you have to somehow solve for. That means you have to write equations/formulas for variables *in terms of other variables*.

In calculus, writing formulas with division in them is often bad (it makes the calculus harder), so we want to write formulas that do not contain division, whenever possible.

EXAMPLE 6

In each picture, write a formula for the quantity marked with a “?” in terms of the other numbers and/or variables in the problem. **Your formula should not contain division by anything other than a constant.**

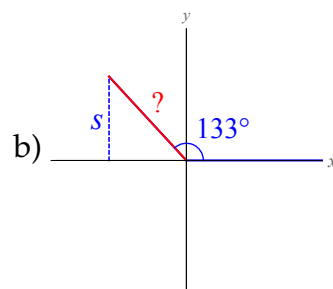
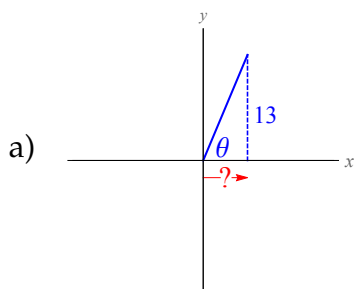

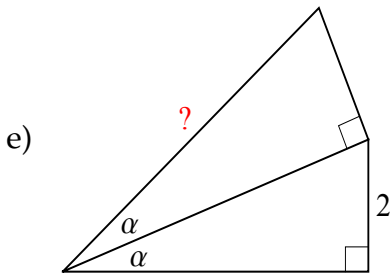
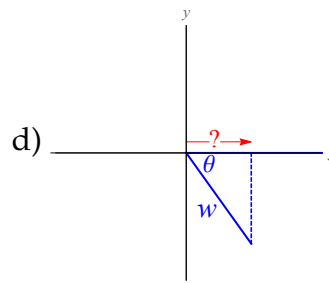
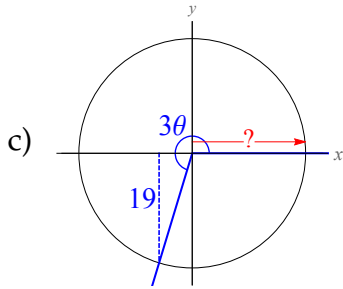

EXAMPLE 7

- a) Let x be the distance from A to B . Write an equation for x in terms of θ . Your equation should not contain division in it.

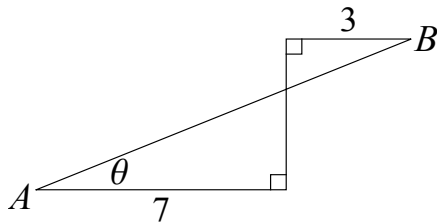

- b) Write an equation for the area of this triangle, in terms of ϕ (as usual, no division is allowed in your formula):

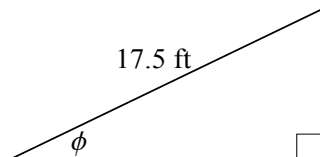

- c) A 12 foot ladder leans up against a house. Write a formula for the distance from the bottom of the ladder to the house, in terms of the angle the ladder makes with the ground (no division allowed).

6.2 More on secant, cosecant and cotangent

Solving for angles, if given the value of a trig function

RECALL

Earlier in the course, we saw that to solve an equation like

$$\sin \theta = .386$$

you compute the _____ of .386 by executing $\boxed{\text{SIN}^{-1}}$.386 on a calculator to obtain one answer

$$\theta = \arcsin .386 = \boxed{22.7^\circ}.$$

This isn't the only answer between 0° and 360° !

Another answer is

$$180^\circ - \arcsin .386 = 180^\circ - 22.7^\circ = \boxed{157.3^\circ}.$$

QUESTION

Your calculator has $\boxed{\text{COS}^{-1}}$, $\boxed{\text{SIN}^{-1}}$ and $\boxed{\text{TAN}^{-1}}$ buttons, but it likely doesn't have $\boxed{\text{SEC}^{-1}}$, $\boxed{\text{CSC}^{-1}}$ and $\boxed{\text{COT}^{-1}}$ buttons.

How then, do you solve equations like

$$\sec \theta = 2.3 \quad \cot \theta = .678 \quad \csc \theta = 5 \quad \text{etc.}?$$

Theorem 6.7 Let q be a number.

Equation	Solutions
$\sin \theta = q$	$\theta = \arcsin q, \theta = 180^\circ - \arcsin q$
$\cos \theta = q$	$\theta = \arccos q, \theta = 360^\circ - \arccos q$
$\tan \theta = q$	$\theta = \arctan q, \theta = \arctan q \pm 180^\circ$
$\csc \theta = q \xrightarrow{\text{reciprocal}} \sin \theta = \frac{1}{q}$	$\theta = \arcsin \frac{1}{q}, \theta = 180^\circ - \arcsin \frac{1}{q}$
$\sec \theta = q \xrightarrow{\text{reciprocal}} \cos \theta = \frac{1}{q}$	$\theta = \arccos \frac{1}{q}, \theta = 360^\circ - \arccos \frac{1}{q}$
$\cot \theta = q \xrightarrow{\text{reciprocal}} \tan \theta = \frac{1}{q}$	$\theta = \arctan \frac{1}{q}, \theta = \arctan \frac{1}{q} \pm 180^\circ$

EXAMPLE 8

For each equation, find an angle between 0° and 90° that solves the given equation. Then find all angles between 0° and 360° that solve the equation.

a) $\sec \theta = 2.3$

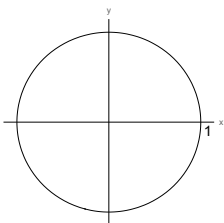

Angle between 0° and 90° :

All angles between 0° and 360° :

b) $\cot \theta = .678$

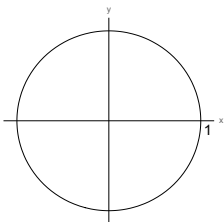

Angle between 0° and 90° :

All angles between 0° and 360° :

c) $\csc \theta = 5$

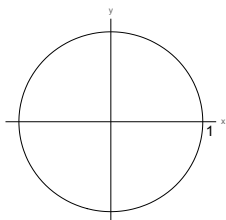
Angle between 0° and 90° :All angles between 0° and 360° :

Signs of the trig functions

Earlier in the course, we learned the pneumonic device

“All Scholars Take Calculus”

which governs the signs of the trig functions. Since a quantity always has the same sign as its reciprocal, we can extend this rule to all six trig functions:

<p>Quadrant II</p> <p>$\sin \theta, \csc \theta > 0$; other trig functions < 0</p> <p>S</p>	<p>Quadrant I</p> <p>A</p> <p>All trig functions > 0</p>
<p>Quadrant III</p> <p>$\tan \theta, \cot \theta > 0$; other trig functions < 0</p> <p>T</p>	<p>Quadrant IV</p> <p>C</p> <p>$\cos \theta, \sec \theta > 0$; other trig functions < 0</p>

EXAMPLE 9

Determine (without a calculator) whether the following quantities are positive or negative:

a) $\csc 322^\circ$

c) $\tan 204^\circ$

b) $\cot 115^\circ$

d) $\tan 515^\circ$

EXAMPLE 10

Determine which quadrant θ lies in, from the given information:

a) $\sin \theta < 0$ and $\cot \theta > 0$

b) $\cos \theta > 0$ and $\csc \theta < 0$

c) $\cot \theta > 0$ and $\cos \theta > 0$

Solution: Since $\cot \theta < 0$, θ is in Quadrant II or IV.

Since $\cos \theta > 0$, θ is in Quadrant I or IV.

Therefore θ is in Quadrant IV.

d) $\cos \theta = -.35$ and $\tan \theta < 0$

Solution: Since $\cos \theta < 0$, θ is in Quadrant II or III.

Since $\tan \theta < 0$, θ is in Quadrant II or IV.

Therefore θ is in Quadrant II.

e) $\csc \theta = -4$ and $\cot \theta < 0$

Solution: Since $\csc \theta < 0$, θ is in Quadrant III or IV.

Since $\cot \theta < 0$, θ is in Quadrant II or IV.

Therefore θ is in Quadrant IV.

f) $\theta = 258704335^\circ$ (using a calculator)

g) $\theta = 243$ radians (using a calculator)

6.3 Trig functions of special angles

In Chapter 3, we discussed how to evaluate the sine, cosine and tangent of any special angle, using reference angles and the ASTC rules. The same methods can be used to compute any trig function of any special angle, except that to get \sec , \csc or \cot , you first compute \cos , \sin or \tan and then take the reciprocal (i.e. flip over the fraction).

Procedure to compute trig functions of special angles

1. Determine whether or not the angle θ is quadrantal (i.e. whether or not θ is a multiple of 90° , or a multiple of $\frac{\pi}{2}$ or π).
2. **If θ is quadrantal**, determine the point on the unit circle at angle θ . This point will be $(\pm 1, 0)$ or $(0, \pm 1)$. Then:

$$\begin{aligned} \cos \theta = x &\longrightarrow \text{flip over } \cos \theta \text{ to get } \sec \theta \\ \sin \theta = y &\longrightarrow \text{flip over } \sin \theta \text{ to get } \csc \theta \\ \tan \theta = \text{slope} &\longrightarrow \text{flip over } \cot \theta \text{ to get } \cot \theta \end{aligned}$$

3. **If θ is not quadrantal**,
 - a) Determine the reference angle $\hat{\theta}$ of θ . The ref. angle will be 30° , 45° or 60° .
 - b) Compute $\sin \hat{\theta}$ or $\cos \hat{\theta}$ with the finger-counting trick, or compute $\tan \hat{\theta}$ by remembering the slopes of these angles.
 - c) If asked to compute $\sec \theta$, $\csc \theta$ or $\cot \theta$, flip over the trig function you found in the previous step as needed.
 - d) Determine the quadrant θ is in; this will tell you the sign of your final answer based on the "All Scholars Take Calculus" rules.
 - e) Your final answer is the $+/-$ sign from step (d) together with the number from steps (b) and (c).

EXAMPLE 11

Compute each quantity:

a) $\sec \frac{11\pi}{6}$

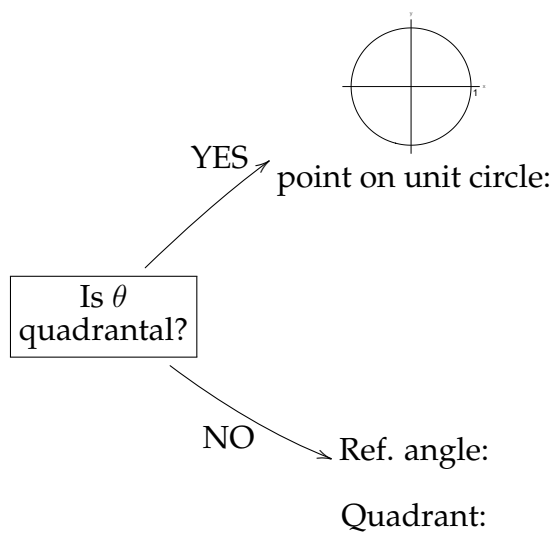

b) $\cot \frac{15\pi}{4}$

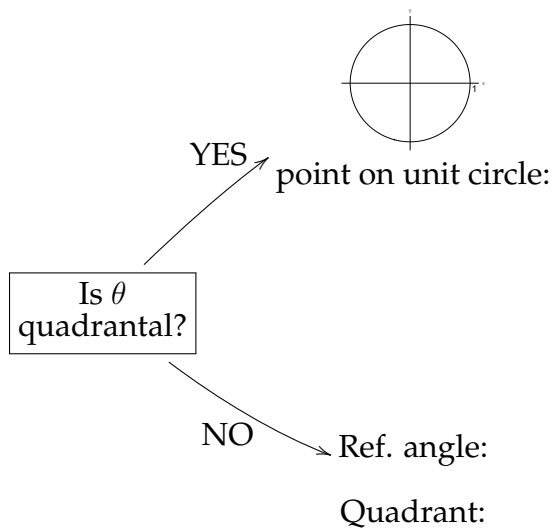

c) $\csc \frac{-5\pi}{6}$

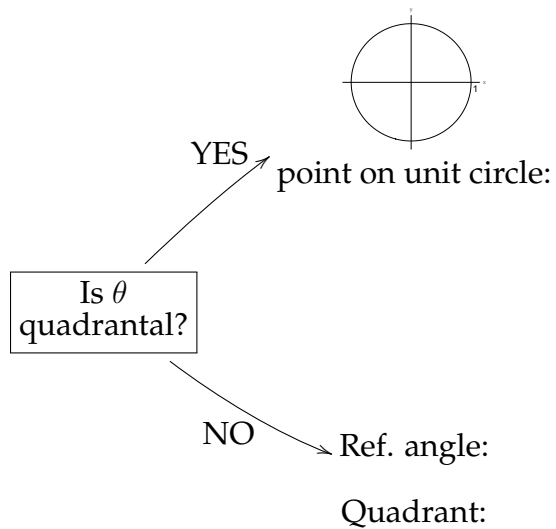

d) $\cot \frac{-3\pi}{2}$

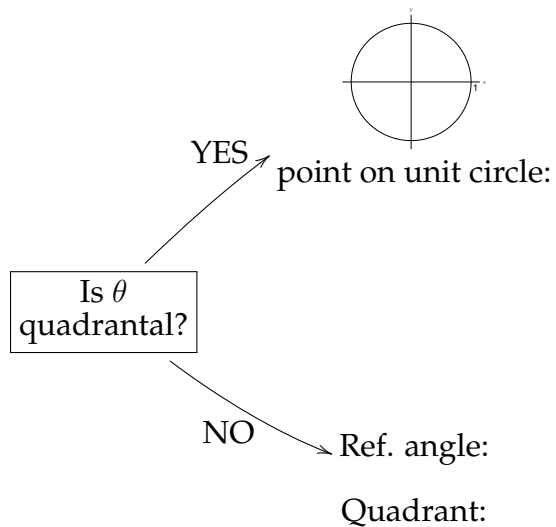

Examples from the first quadrant**EXAMPLE 12**

Compute each quantity:

a) $\sec 60^\circ$

b) $\csc \frac{\pi}{4}$

c) $\tan 0$

d) $\cot \frac{\pi}{3}$

e) $\sin 30^\circ$

f) $\tan 90^\circ$

g) $\cot 45^\circ$

h) $\csc 30^\circ$

i) $\csc 90^\circ$

j) $\sec 0^\circ$

k) $\sec \frac{\pi}{6}$

Theorem 6.8 (Values of the trig functions in Quadrant I)

θ (degrees)	θ (radians)	$\sin \theta$	$\cos \theta$	$\tan \theta$	$\cot \theta$	$\sec \theta$	$\csc \theta$
0°	0	0	1	0	DNE	1	DNE
30°	$\frac{\pi}{6}$	$\frac{1}{2}$	$\frac{\sqrt{3}}{2}$	$\frac{1}{\sqrt{3}}$	$\sqrt{3}$	$\frac{2}{\sqrt{3}}$	2
45°	$\frac{\pi}{4}$	$\frac{\sqrt{2}}{2}$	$\frac{\sqrt{2}}{2}$	1	1	$\frac{2}{\sqrt{2}}$	$\frac{2}{\sqrt{2}}$
60°	$\frac{\pi}{3}$	$\frac{\sqrt{3}}{2}$	$\frac{1}{2}$	$\sqrt{3}$	$\frac{1}{\sqrt{3}}$	2	$\frac{2}{\sqrt{3}}$
90°	$\frac{\pi}{2}$	1	0	DNE	0	DNE	1

EXAMPLE 13

Compute each quantity:

a) $\sec(-120^\circ)$

b) $\csc\left(\frac{-9\pi}{4}\right)$

c) $\cot\left(-\frac{2\pi}{3}\right)$

d) $\cot\frac{19\pi}{6}$

e) $\sec 180^\circ$

f) $\tan 495^\circ$

g) $\cos \frac{11\pi}{6}$

h) $\sin 120^\circ$

i) $\sec 225^\circ$

j) $\cot 270^\circ$

k) $\tan \frac{\pi}{3}$

l) $\csc(-150^\circ)$

m) $\tan \frac{7\pi}{2}$

n) $\cot \frac{5\pi}{6}$

o) $\csc 0$

p) $\sin \frac{11\pi}{4}$

q) $\sec(-855^\circ)$

r) $\tan 540^\circ$

Examples with more complicated expressions**EXAMPLE 14**

Compute the following:

a) $\cos 2 \cdot 90^\circ$

b) $2 \cos 90^\circ$

c) $2 \sec 2 \cdot \frac{\pi}{3}$

d) $\sin \frac{3\pi}{4} + \cos \frac{3\pi}{2}$

e) $\cot \frac{-2\pi}{3} \csc \frac{7\pi}{6}$

f) $\tan \frac{3\pi}{4} - 2 \tan \frac{5\pi}{4}$

g) $\cot \left(\frac{7\pi}{6} + \frac{\pi}{6} \right)$

h) $\cot \frac{7\pi}{6} + \frac{\pi}{6}$

i) $\sin^2 135^\circ$

j) $\csc^2 \frac{3\pi}{2}$

k) $\sec^4 240^\circ$

l) $3 \cot^4(-315^\circ)$

6.4 Pythagorean identities

Theorem 6.9 (Pythagorean identities)

$$\cos^2 \theta + \sin^2 \theta = 1 \qquad \sec^2 \theta = 1 + \tan^2 \theta \qquad \csc^2 \theta = 1 + \cot^2 \theta$$

PROOFS (of the Pythagorean identities) We already learned $\cos^2 \theta + \sin^2 \theta = 1$.

$$\cos^2 \theta + \sin^2 \theta = 1$$

$$\cos^2 \theta + \sin^2 \theta = 1$$

The purpose of these identities is that if you know the **value of any one of the six trig functions**, and you know the **sign of a different trig function**, you can compute the values of any of the other trig functions by following the arrows in this diagram (and maybe using the quotient identities as shortcuts).

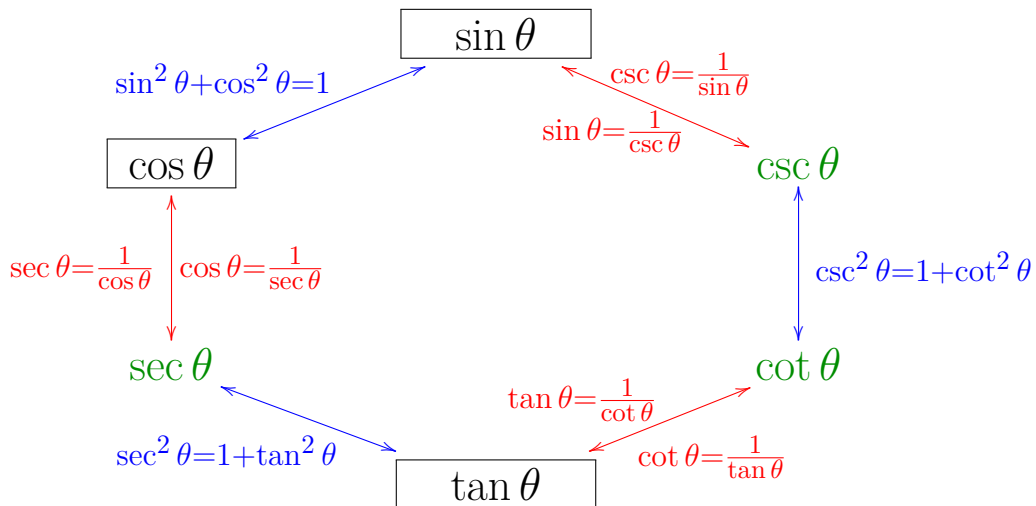

EXAMPLE 15

Find all possible values of $\tan \theta$, if $\sec \theta = -3$.

EXAMPLE 16

Find the values of all six trig functions of θ , from the given information:

a) $\sin \theta = \frac{2}{3}$ and $\cot \theta < 0$

$$\sin \theta = \frac{2}{3}$$

$$\cos \theta =$$

$$\tan \theta =$$

$$\csc \theta =$$

$$\sec \theta =$$

$$\cot \theta =$$

b) $\cot \theta = 4$ and $\csc \theta > 0$

First, since $\cot \theta > 0$ and $\csc \theta > 0$, θ is in Quadrant I, so all six trig functions are positive.

Second, $\tan \theta = \frac{1}{\cot \theta} = \frac{1}{4}$. From here, there are two ways to proceed:

Solution # 1: Use identity $\cot^2 \theta + 1 = \csc^2 \theta$:

$$\begin{aligned} 4^2 + 1 &= \csc^2 \theta \\ 17 &= \csc^2 \theta \\ \pm\sqrt{17} &= \csc \theta \\ \sqrt{17} &= \csc \theta \text{ (since we are in Quadrant I).} \end{aligned}$$

Thus $\sin \theta = \frac{1}{\csc \theta} = \frac{1}{\sqrt{17}}$. Now, use a quotient identity:

$$\begin{aligned} \tan \theta &= \frac{\sin \theta}{\cos \theta} \\ \frac{1}{4} &= \frac{1/\sqrt{17}}{\cos \theta} \\ \cos \theta &= \frac{4}{\sqrt{17}} \end{aligned}$$

Last, $\sec \theta = \frac{1}{\cos \theta} = \frac{\sqrt{17}}{4}$. Therefore:

$\sin \theta = \frac{1}{\sqrt{17}}$	$\cos \theta = \frac{4}{\sqrt{17}}$	$\tan \theta = \frac{1}{4}$
$\csc \theta = \sqrt{17}$	$\sec \theta = \frac{\sqrt{17}}{4}$	$\cot \theta = 4$

You can also do this problem by sketching the following triangle:

Odd-even identities

Theorem 6.10 (Odd-even identities)

$$\begin{aligned} \sin(-\theta) &= -\sin \theta & \cos(-\theta) &= \cos \theta & \tan(-\theta) &= -\tan \theta \\ \csc(-\theta) &= -\csc \theta & \sec(-\theta) &= \sec \theta & \cot(-\theta) &= -\cot \theta \end{aligned}$$

PROOF We already know $\sin(-\theta) = -\sin \theta$, $\cos(-\theta) = \cos \theta$ and $\tan(-\theta) = -\tan \theta$.

$$\text{So } \csc(-\theta) = \frac{1}{\sin(-\theta)} = \frac{1}{-\sin \theta} = -\frac{1}{\sin \theta} = -\csc \theta.$$

$$\text{Also, } \sec(-\theta) = \frac{1}{\cos(-\theta)} = \frac{1}{\cos \theta} = \sec \theta.$$

$$\text{Last, } \cot(-\theta) = \frac{1}{\tan(-\theta)} = \frac{1}{-\tan \theta} = -\frac{1}{\tan \theta} = -\cot \theta. \quad \square$$

EXAMPLE 17

a) Suppose $\tan \theta = 3.25$. Compute $\tan(-\theta)$.

b) Suppose $\sec \theta = -1.3$. Compute $\sec(-\theta)$.

c) Suppose $\cot \theta = -\frac{3}{8}$. Compute $\cot(-\theta)$.

Solution: Since $\cot(-\theta) = -\cot \theta$, we see that $\cot(-\theta) = -\left(-\frac{3}{8}\right) = \boxed{\frac{3}{8}}$.

d) Suppose $\sin \theta = \frac{2}{3}$. Compute $\csc(-\theta)$.

Simplifying quantities involving identities and symmetry**EXAMPLE 18**

Compute each quantity (without using a calculator):

a) $\sin^2 70^\circ + \cos^2 70^\circ$

b) $\sin 40^\circ + \sin(-40^\circ)$

c) $\sin 80^\circ - \cos 10^\circ$

d) $\cot 133^\circ \tan 133^\circ$

e) $3 \cos^2 \frac{7\pi}{19} + 3 \sin^2 \frac{7\pi}{19}$

f) $\tan^2 808^\circ - \sec^2 808^\circ$

g) $\tan \frac{6\pi}{5} - \tan \frac{\pi}{5}$

6.5 Graphs of cosecant, secant and cotangent

The graph of $y = \csc x$

The function $y = \csc x$ can also be written $y = \frac{1}{\sin x}$. Therefore the graph of $y = \csc x$ should be related to the graph of $y = \sin x$. But how, exactly?

Let's try a table of values for $y = \csc x$:

x	$\sin x$	point on $y = \sin x$	$\csc x = \frac{1}{\sin x}$	point on $y = \csc x$
0	0	(0, 0)		
$\frac{\pi}{6}$	$\frac{1}{2} = .5$	$(\frac{\pi}{6}, .5)$	$\frac{1}{\frac{1}{2}} = 2$	$(\frac{\pi}{6}, 2)$
$\frac{\pi}{4}$	$\frac{\sqrt{2}}{2} \approx .707$	$(\frac{\pi}{4}, .707)$	$\frac{1}{\frac{\sqrt{2}}{2}} = \sqrt{2} \approx 1.414$	$(\frac{\pi}{4}, 1.414)$
$\frac{\pi}{2}$	1	$(\frac{\pi}{2}, 1)$	$\frac{1}{1} = 1$	$(\frac{\pi}{2}, 1)$
$\frac{3\pi}{4}$	$\frac{\sqrt{2}}{2} \approx .707$	$(\frac{3\pi}{4}, .707)$	$\frac{1}{\frac{\sqrt{2}}{2}} = \sqrt{2} \approx 1.414$	$(\frac{3\pi}{4}, 1.414)$
$\frac{5\pi}{6}$	$\frac{1}{2} = .5$	$(\frac{5\pi}{6}, .5)$	$\frac{1}{\frac{1}{2}} = 2$	$(\frac{5\pi}{6}, 2)$
π	0	$(\pi, 0)$	DNE	DNE
$\frac{7\pi}{6}$	$\frac{-1}{2} = -.5$	$(\frac{7\pi}{6}, -.5)$	$\frac{1}{\frac{-1}{2}} = -2$	$(\frac{7\pi}{6}, -2)$
$\frac{3\pi}{2}$	-1	$(\frac{3\pi}{2}, -1)$	$\frac{1}{-1} = -1$	$(\frac{3\pi}{2}, -1)$
$\frac{11\pi}{6}$	$\frac{-1}{2} = -.5$	$(\frac{11\pi}{6}, -.5)$	$\frac{1}{\frac{-1}{2}} = -2$	$(\frac{11\pi}{6}, -2)$
2π	0	$(2\pi, 0)$	DNE	DNE

OBSERVATIONS

6.5. Graphs of cosecant, secant and cotangent

Based on the observations on the previous page, we can sketch the graph of $y = \csc x$:

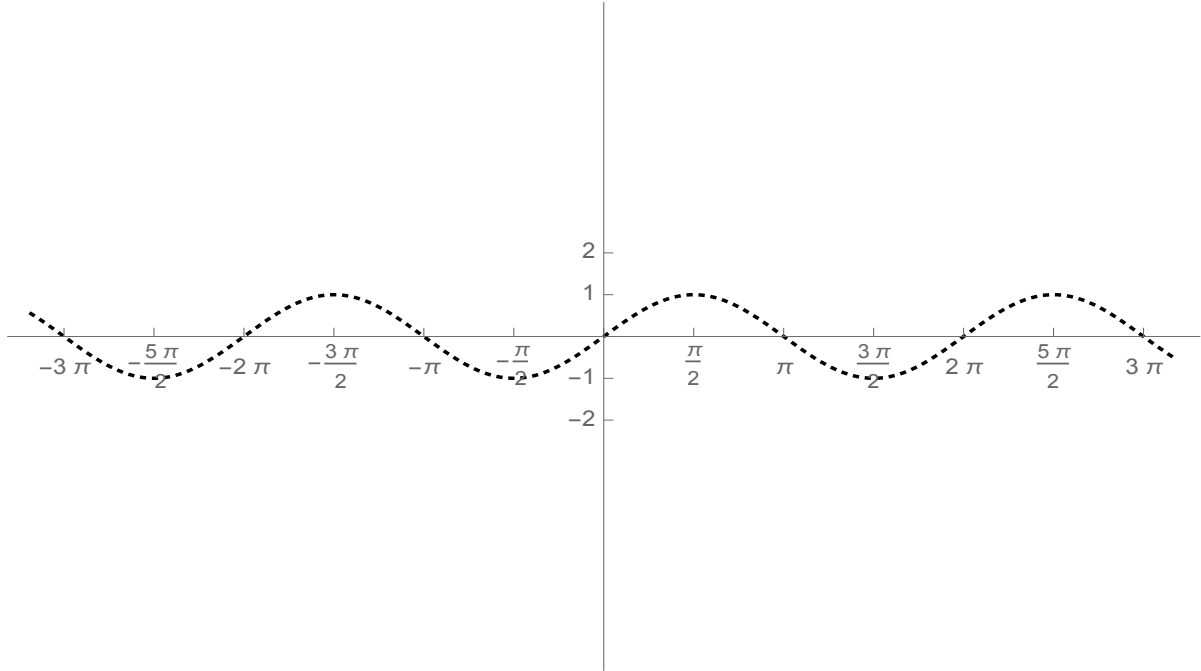

The graph of $y = \sec x$

The graph of $y = \sec x$ is related to the graph of $y = \cos x$ in the same way that the graph of $y = \csc x$ is related to $y = \sin x$:

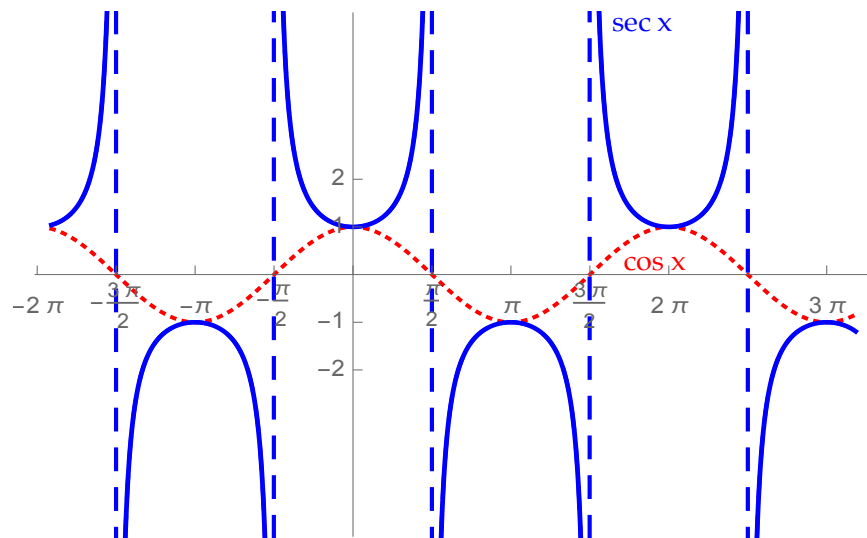

The graph of $y = \cot x$

We will determine the graph of $y = \cot x$ in a similar way as how we graphed $y = \tan x$. First, we can write $y = \cot x = \frac{\cos x}{\sin x}$. This means:

- when $\sin x = 0$, $\cot x$

The values of x where this happens are $x = 0, \pi, 2\pi, 3\pi, \dots, -\pi, -2\pi, -3\pi, \dots$

- when $\cos x = 0$, $\cot x$

The values of x where this happens are $x = \frac{\pi}{2}, \frac{3\pi}{2}, \frac{5\pi}{2}, \dots, -\frac{\pi}{2}, -\frac{3\pi}{2}, \dots$

Putting this together with a table of values similar to the one we did for $y = \tan x$, we get this graph of $y = \cot x$:

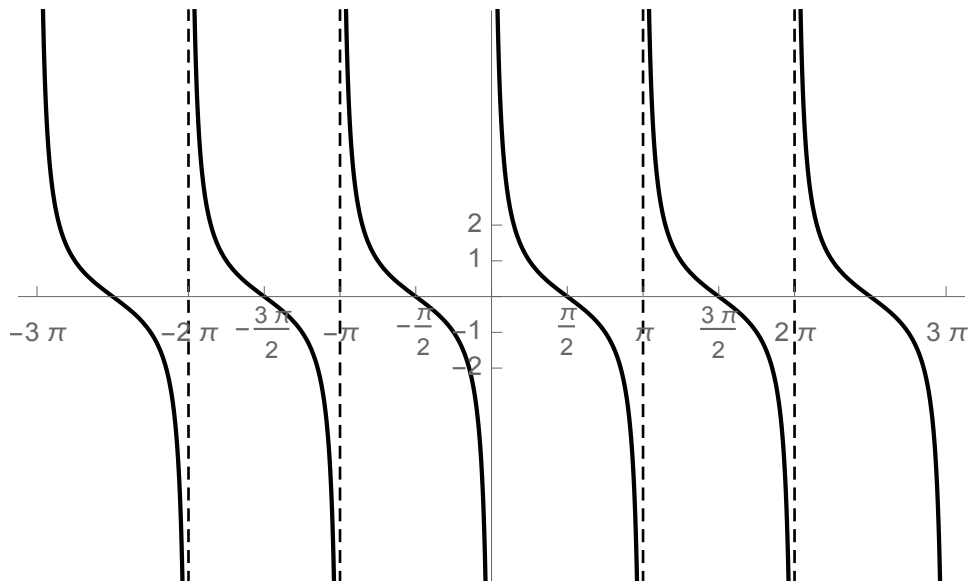

6.5. Graphs of cosecant, secant and cotangent

Summary

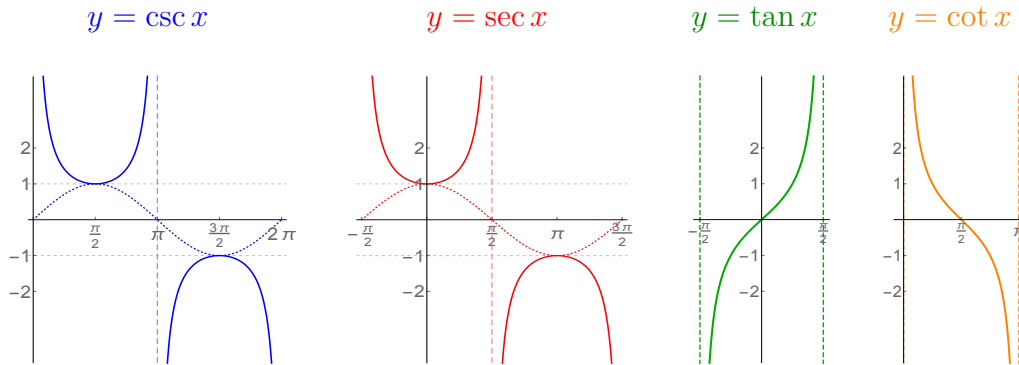

For each of these functions, there are dashed vertical lines called **asymptotes** which the graph does not cross (the graph appears to “merge” into the asymptote but never actually touches it). Here are the essential properties of these functions, which are reflected in the crude graphs drawn above:

FUNCTION	LOCATIONS OF ASYMPTOTES	PLACES WHERE GRAPH CROSSES x -AXIS	PERIOD	PIECES OF THE GRAPH ROUGHLY LOOK LIKE
$y = \csc x$	$x = 0, \pi, 2\pi, \dots$ $x = -\pi, -2\pi, -3\pi, \dots$ (where $\sin x = 0$)	None	2π	parabolas
$y = \sec x$	$x = \frac{\pi}{2}, \frac{3\pi}{2}, \frac{5\pi}{2}, \dots$ $x = -\frac{\pi}{2}, -\frac{3\pi}{2}, -\frac{5\pi}{2}, \dots$ (where $\cos x = 0$)	None	2π	parabolas
$y = \tan x$	$x = \frac{\pi}{2}, \frac{3\pi}{2}, \frac{5\pi}{2}, \dots$ $x = -\frac{\pi}{2}, -\frac{3\pi}{2}, -\frac{5\pi}{2}, \dots$ (where $\cos x = 0$)	$x = 0, \pi, 2\pi, \dots$ $x = -\pi, -2\pi, -3\pi, \dots$ (where $\sin x = 0$)	π	cubics going up from left to right
$y = \cot x$	$x = 0, \pi, 2\pi, \dots$ $x = -\pi, -2\pi, -3\pi, \dots$ (where $\sin x = 0$)	$x = \frac{\pi}{2}, \frac{3\pi}{2}, \frac{5\pi}{2}, \dots$ $x = -\frac{\pi}{2}, -\frac{3\pi}{2}, -\frac{5\pi}{2}, \dots$ (where $\cos x = 0$)	π	cubics going down from left to right

Chapter 7

Trigonometric algebra

7.1 Elementary trig identities

Theorem 7.1 (Reciprocal identities)

$$\begin{aligned} \csc \theta &= \frac{1}{\sin \theta} & \sec \theta &= \frac{1}{\cos \theta} & \cot \theta &= \frac{1}{\tan \theta} \\ \sin \theta &= \frac{1}{\csc \theta} & \cos \theta &= \frac{1}{\sec \theta} & \tan \theta &= \frac{1}{\cot \theta} \end{aligned}$$

Theorem 7.2 (Quotient identities)

$$\tan \theta = \frac{\sin \theta}{\cos \theta} \quad \cot \theta = \frac{\cos \theta}{\sin \theta}$$

Theorem 7.3 (Pythagorean identities)

$$\sin^2 \theta + \cos^2 \theta = 1 \quad \sec^2 \theta = 1 + \tan^2 \theta \quad \csc^2 \theta = 1 + \cot^2 \theta$$

Theorem 7.4 (Odd-even identities)

$$\begin{aligned} \sin(-\theta) &= -\sin \theta & \cos(-\theta) &= \cos \theta & \tan(-\theta) &= -\tan \theta \\ \csc(-\theta) &= -\csc \theta & \sec(-\theta) &= \sec \theta & \cot(-\theta) &= -\cot \theta \end{aligned}$$

It is good to know these identities is that they allow you to simplify more complicated trig expressions that may arise in a problem.

EXAMPLE 1

Write an equation for the “?” in terms of θ , and simplify your answer:

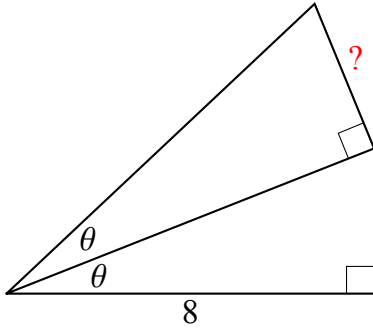
**Alternate forms of the Pythagorean identities**

Consider the statement “ $3 + 5 = 8$ ”. There are several ways to restate this fact, all of which are equivalent:

There are also some incorrect ways to restate this:

Each of the Pythagorean identities can be rewritten in similar ways:

$$\sin^2 \theta + \cos^2 \theta = 1 \quad \sec^2 \theta = 1 + \tan^2 \theta \quad \csc^2 \theta = 1 + \cot^2 \theta$$

EXAMPLE 2

If the following expressions can be simplified, simplify them. If they cannot be simplified, do nothing.

$\tan^2 \theta + 1$

$\csc^2 \theta + \sin^2 \theta$

$\tan^2 \theta - 1$

$\cot^2 \theta + 1$

$1 - \sec^2 \theta$

$1 - \sin^2 \theta$

$\sin^2 \theta + \cos^2 \theta$

$\csc^2 \theta - 1$

$\sec^2 \theta - \tan^2 \theta$

$\csc^2 \theta - \sec^2 \theta$

$1 + \csc^2 \theta$

$1 - \cos^2 \theta$

$1 + \cos^2 \theta$

$\sec^2 \theta - 1$

$1 + \tan^2 \theta$

$\cot^2 \theta - 1$

$1 - \csc^2 \theta$

$1 + \cot^2 \theta$

Simplifying trig expressions**Procedure to simplify a trig expression**

1. Use odd-even identities to remove any $-$ signs from inside the trig functions.
2. If possible, simplify (part of) the expression using a Pythagorean identity.
3. Write whatever is left in terms of sines and cosines, using the quotient and reciprocal identities.
4. Simplify using algebra.

EXAMPLE 3

Simplify each expression as much as possible, and write your answer so that no quotients appear in the final answer.

a) $\tan \theta \cos \theta$

b) $\csc \theta \cos \theta \tan \theta$

c) $\frac{\tan(-\theta)}{\sec \theta}$

d) $\frac{1 - \sin^2(-\theta)}{1 + \cot^2(-\theta)}$

Verifying identities

Suppose you are given a weird looking equation (or “identity”) involving trig functions. To verify that the identity is true, work out both sides in terms of sines and cosines, using algebra to simplify when possible, and check that both sides work out to the same thing. Until you know the sides are equal, don’t claim they are equal by writing a “=”.

EXAMPLE 4

Verify that each equation is an identity:

a) $\frac{\tan \theta}{\sec \theta} = \sin \theta$

b) $\sin^2 x(1 + \cot^2 x) = 1$

c) $\frac{\csc \theta \sec \theta}{\cot \theta} = \tan^2 \theta + 1$

7.2 Sum and difference identities

We have seen several times in this course that if α and β are two angles, then in general,

$$\sin(\alpha + \beta) \neq \sin \alpha + \sin \beta$$

(and similarly for cosine, tangent, secant, etc.)

QUESTION

Can you figure $\sin(\alpha + \beta)$ from $\sin \alpha$ and $\sin \beta$?

ANSWER

1. **DO NOT DISTRIBUTE:** $\sin(\alpha + \beta) \neq \sin \alpha + \sin \beta$, etc.
2. It is doable to evaluate expressions like $\sin(\alpha + \beta)$, but
3. to evaluate expressions like $\sin(\alpha + \beta)$, you have to use identities you should look up. **These identities will be given to you on any quiz or exam. They do not need to be memorized.**

Theorem 7.5 (Sum Identities)

$$\sin(\alpha + \beta) = \sin \alpha \cos \beta + \cos \alpha \sin \beta$$

$$\cos(\alpha + \beta) = \cos \alpha \cos \beta - \sin \alpha \sin \beta$$

$$\tan(\alpha + \beta) = \frac{\tan \alpha + \tan \beta}{1 - \tan \alpha \tan \beta}$$

Theorem 7.6 (Difference Identities)

$$\sin(\alpha - \beta) = \sin \alpha \cos \beta - \cos \alpha \sin \beta$$

$$\cos(\alpha - \beta) = \cos \alpha \cos \beta + \sin \alpha \sin \beta$$

$$\tan(\alpha - \beta) = \frac{\tan \alpha - \tan \beta}{1 + \tan \alpha \tan \beta}$$

The next few pages give some examples of how we apply these identities.

EXAMPLE 5

- a) Find $\sin(\alpha + \beta)$ if α is in Quadrant II, β is in Quadrant I, $\sin \alpha = \frac{3}{5}$ and $\sin \beta = \frac{2}{3}$.

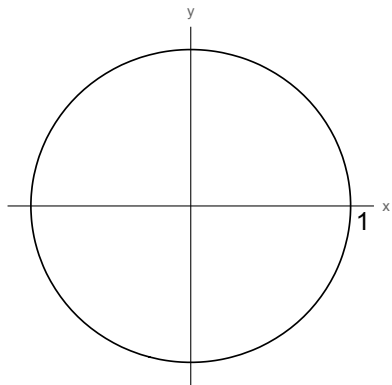

- b) Compute $\tan(\alpha - \beta)$ if $\tan \alpha = 2$, $\tan \beta = 3$, $\sin \alpha < 0$ and $\cos \beta > 0$.

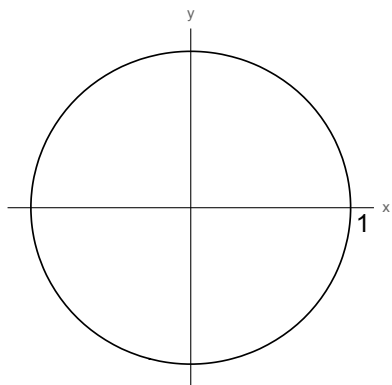

c) Compute the exact value of $\sin 165^\circ$.

d) Compute the exact value of $\cos 15^\circ$.

Solution: Think of 15° as $60^\circ - 45^\circ$. Then

$$\begin{aligned}\cos 15^\circ &= \cos(60^\circ - 45^\circ) \\ &= \cos 60^\circ \cos 45^\circ + \sin 60^\circ \sin 45^\circ \quad (\text{by the difference identity}) \\ &= \frac{1}{2} \cdot \frac{\sqrt{2}}{2} + \frac{\sqrt{3}}{2} \cdot \frac{\sqrt{2}}{2} \\ &= \frac{\sqrt{2}}{4} + \frac{\sqrt{6}}{4} \\ &= \boxed{\frac{\sqrt{2} + \sqrt{6}}{4}}.\end{aligned}$$

e) Find the exact value of $\sin(\alpha + 60^\circ)$, if $\sin \alpha = \frac{4}{9}$ and $\cos \alpha > 0$.

Solution:

$$\begin{aligned}\sin(\alpha + 60^\circ) &= \sin \alpha \cos 60^\circ + \cos \alpha \sin 60^\circ \quad (\text{by the addition identity}) \\ &= \frac{4}{9} \cdot \frac{1}{2} + (\cos \alpha) \frac{\sqrt{3}}{2} \\ &= \frac{4}{9} \cdot \frac{1}{2} + \frac{\sqrt{65}}{9} \cdot \frac{\sqrt{3}}{2} \\ &= \frac{4}{18} + \frac{\sqrt{195}}{18} \\ &= \boxed{\frac{4 + \sqrt{195}}{18}}.\end{aligned}$$

7.3 More identities

Earlier we learned that trig functions do not respect multiplication and division, i.e.

$$\sin 2\theta \neq 2 \sin \theta \qquad \cos \frac{\theta}{2} \neq \frac{\cos \theta}{2}$$

QUESTION

How can you simplify/rewrite expressions like $\sin 2\theta$ or $\cos \frac{\theta}{2}$?

ANSWER

1. **DO NOT PULL THE CONSTANT OUT:** $\sin 2\theta \neq 2 \sin \theta$, etc.
2. It is doable to evaluate expressions like $\sin 2\theta$, but
3. to evaluate expressions like $\sin 2\theta$, you have to use identities you should look up. **These identities will be given to you on any quiz or exam. They do not need to be memorized.**

Theorem 7.7 (Double-angle Identities)

$$\begin{aligned}\sin 2\theta &= 2 \sin \theta \cos \theta \\ \cos 2\theta &= 2 \cos^2 \theta - 1 = 1 - 2 \sin^2 \theta = \cos^2 \theta - \sin^2 \theta \\ \tan 2\theta &= \frac{2 \tan \theta}{1 - \tan^2 \theta}\end{aligned}$$

Theorem 7.8 (Half-angle Identities)

$$\begin{aligned}\sin \frac{\theta}{2} &= \pm \sqrt{\frac{1 - \cos \theta}{2}} \\ \cos \frac{\theta}{2} &= \pm \sqrt{\frac{1 + \cos \theta}{2}} \\ \tan \frac{\theta}{2} &= \frac{1 - \cos \theta}{\sin \theta}\end{aligned}$$

EXAMPLE 6

a) Compute $\sin 2\theta$, if $\sin \theta = \frac{3}{4}$ and $\cos \theta < 0$.

b) Compute the exact value of $\sin 22.5^\circ$.

Solution:

$$\sin 22.5^\circ = \sin \frac{45^\circ}{2} = \sqrt{\frac{1 - \cos 45^\circ}{2}} = \sqrt{\frac{1 - \frac{\sqrt{2}}{2}}{2}}.$$

c) Express $\cos 3\theta$ in terms of trig functions of angle θ .

Last, here are some more identities that allow you to convert between sums of trig expressions and products of trig expressions. They are occasionally used in acoustics and the study of waves (light waves, sound waves, radio waves, etc.), but if you ever needed one of these identities, you'd just look it up (in fact, your professor doesn't even know these off the top of his head... that said, he is aware of their existence and you should be too).

Theorem 7.9 (Sum-to-Product Identities)

$$\begin{aligned}\sin \alpha + \sin \beta &= 2 \sin \frac{\alpha + \beta}{2} \cos \frac{\alpha - \beta}{2} \\ \sin \alpha - \sin \beta &= 2 \cos \frac{\alpha + \beta}{2} \sin \frac{\alpha - \beta}{2} \\ \cos \alpha + \cos \beta &= 2 \cos \frac{\alpha + \beta}{2} \cos \frac{\alpha - \beta}{2} \\ \cos \alpha - \cos \beta &= -2 \sin \frac{\alpha + \beta}{2} \sin \frac{\alpha - \beta}{2}\end{aligned}$$

Theorem 7.10 (Product-to-Sum Identities)

$$\begin{aligned}\sin \alpha \sin \beta &= \frac{1}{2} [\cos(\alpha - \beta) - \cos(\alpha + \beta)] \\ \cos \alpha \cos \beta &= \frac{1}{2} [\cos(\alpha - \beta) + \cos(\alpha + \beta)] \\ \sin \alpha \cos \beta &= \frac{1}{2} [\sin(\alpha - \beta) + \sin(\alpha + \beta)]\end{aligned}$$

Chapter 8

Homework exercises

Here are a couple of codes that I use to label homework exercises throughout these notes:

NC: you should be able to do this problem **without** a calculator.

OPT: this exercise is essentially a repeat of a previous exercise, so you can skip it if you haven't had difficulty with the previous question(s)

8.1 Chapter 1 Homework

§1.1: What is allowed? What isn't allowed?

In Exercises 1-8, perform the indicated operation, and simplify if possible.

1. $1 \div \frac{a}{b}$

5. $\frac{\pi}{6} \cdot \frac{180}{\pi}$

2. $1 \div \left(-\frac{2}{7}\right)$

6. $\frac{\pi}{3} + \pi$

3. $\frac{1}{\frac{9}{c}}$

7. $\frac{\frac{2}{7}}{\frac{5}{3}}$

4. $20 \cdot \frac{\pi}{180}$

8. $\frac{\frac{x}{6}}{\frac{x}{2}}$

In Exercises 9-20, classify each statement as TRUE or FALSE (remember that in math, for a statement to be true means that it must be true no matter what you plug in for the variables):

- | | | |
|--|--|---------------------------|
| 9. $(x - 2)^2 = x^2 - 2^2$ | 13. $(4x)^2 = 4x^2$ | 17. $5 + x^2 = 5 + (x^2)$ |
| 10. $3^2x^2 = (3x)^2$ | 14. $\sqrt{\frac{5}{3}} = \frac{\sqrt{5}}{\sqrt{3}}$ | 18. $6^2 = 12$ |
| 11. $3 + \frac{8}{5} = \frac{11}{5}$ | 15. $\sqrt{6x} = \sqrt{6}\sqrt{x}$ | 19. $x^2 = (\sqrt{x})^4$ |
| 12. $\sqrt{x-1} = \sqrt{x} - \sqrt{1}$ | 16. $\frac{\frac{3}{7}}{2} = \frac{\frac{3}{2}}{7}$ | 20. $(x^4)^3 = x^{12}$ |

Answers

IMPORTANT: I did the answers to all my homework problems by hand; so it is possible that they contain errors. Extra credit can be earned by bringing mistakes to my attention.

- | | | |
|--|---|-----------|
| 1. $1 \div \frac{a}{b} = \boxed{\frac{b}{a}}$ | 6. $\frac{\pi}{3} + \pi = \boxed{\frac{4\pi}{3}}$ | 12. FALSE |
| 2. $1 \div \left(-\frac{2}{7}\right) = \boxed{-\frac{7}{2}}$ | 7. $\frac{\frac{2}{7}}{\frac{5}{3}} = \boxed{\frac{6}{35}}$ | 13. FALSE |
| 3. $\frac{1}{\frac{9}{c}} = \boxed{\frac{c}{9}}$ | 8. $\frac{\frac{x}{6}}{\frac{x}{2}} = \boxed{\frac{1}{3}}$ | 14. TRUE |
| 4. $20 \cdot \frac{\pi}{180} = \boxed{\frac{\pi}{9}}$ | 9. FALSE | 15. TRUE |
| 5. $\frac{\pi}{6} \cdot \frac{180}{\pi} = \boxed{30}$ | 10. TRUE | 16. TRUE |
| | 11. FALSE | 17. TRUE |
| | | 18. FALSE |
| | | 19. TRUE |
| | | 20. TRUE |

§1.2: Solving basic equations

1. Solve each equation for x :

a) $\frac{3}{8}x = 54$

b) $5x - 3 = 4(x + 1)$

c) $7x - 5 = 3x + 17$

d) $x + .63 = 3(x - .35) + .1$

2. Solve each equation for \sqrt{x} :

a) $5\sqrt{x} + 2 = 37$

b) $7(\sqrt{x} - 5) = 11(3 - 2\sqrt{x})$

3. Solve each equation for "cos x ":

a) $18^2 = 5^2 + 17^2 - 2(5)(17) \cos x$

b) $35^2 = 18^2 + 15^2 - 2(18)(15) \cos x$

4. Solve each equation for x :

a) $x^2 = 64$

c) $x^2 + (.3)^2 = 1$

b) $x^2 + 5x = 36$

d) $(8.25)^2 + (7.5)^2 = x^2$

5. Solve each equation for x :

a) $\frac{x}{5} = \frac{7}{11}$

c) $\frac{x}{9} = \frac{4}{x}$

b) $\frac{x}{2x-3} = \frac{19}{24}$

d) $\frac{3}{x+2} = \frac{8}{7}$

6. Solve each equation for "sin x ":

a) $\frac{\sin x}{8.3} = \frac{.745}{19}$

b) $\frac{22}{\sin x} = \frac{45}{.873}$

c) $\frac{.458}{18.6} = \frac{\sin x}{25.3}$

Answers

1. a) $x = 144$ b) $x = 7$ c) $x = \frac{11}{2} = 5.5$ d) $x = .79$
2. a) $\sqrt{x} = 7$ b) $\sqrt{x} = \frac{68}{29}$
3. a) $\cos x = \frac{-1}{17} = -.0588235$ b) $\cos x = \frac{-169}{135} = -1.25185$
4. a) $x = \pm 8$ c) $x = \pm .953939$
 b) $x = -9, x = 4$ d) $x = \pm 11.1496$
5. a) $x = \frac{35}{11} = 3.18182$ c) $x = \pm 6$
 b) $x = \frac{57}{14} = 4.07143$ d) $x = \frac{5}{8} = .675$
6. a) $\sin x = .325447$ b) $\sin x = .4268$ c) $\sin x = .622978$

§1.3: Functions

1. **NC** Determine which one or ones of the following graphs represent functions:

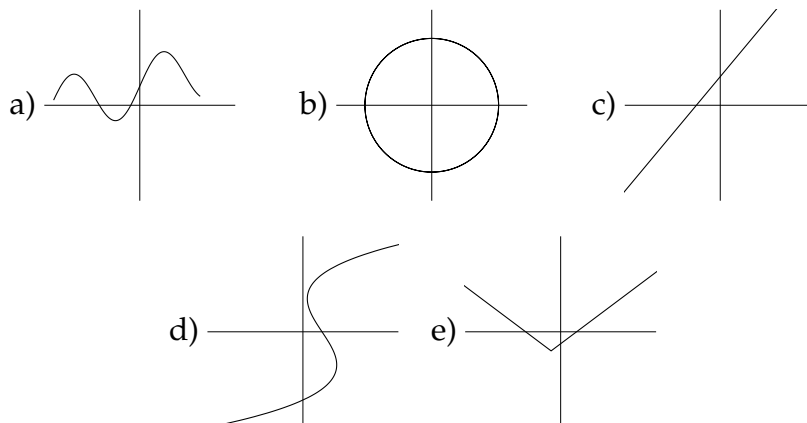

2. **NC** Let h be the function which takes input x , multiplies the input by 10, then subtracts 15. Write the formula for h , and compute $h(6)$.

3. **NC** Let $f(x) = 3x - 1$ and let $g(x) = x^2 + 1$. Compute each of the following quantities:

a) $f(2)$	c) $4f\left(\frac{2}{3}\right)$	e) $3 + g(6)$	g) $f(5) + g(5)$
b) $g(-3)$	d) $g(t)$	f) $f(2x)$	h) $f(3) - g(4)$

4. **NC** Let f be the function defined by $f(x) = 2x - 3$. Compute each of the following quantities:

a) $f(1)$	g) $1 - f(2)$
b) $f(-3)$	h) $2f(4)$
c) $f(1 - 2)$	i) $f(2)4$
d) $f(1) - f(2)$	j) $4f(2)$
e) $f(1) + f(-2)$	k) $f(2 \cdot 4)$
f) $f(1) - 2$	l) $2f(3) - 5f(1)$

5. **NC** Let g be the function defined by $g(x) = x^2 - x$. Compute each of the following quantities:

a) $g(3)$	c) $2g(3)$	e) $g(-2) + 4$
b) $g(2 \cdot 3)$	d) $g(-2 + 4)$	f) $g(-2 \cdot 5) - 20$

6. **NC** Let dog be the function defined by the following procedure: if the input x is odd, then $\text{dog } x = x + 1$. If the input x is even, then $\text{dog } x = x - 1$. Compute each of the following quantities:

- | | | |
|--------------------------|--|------------------------------|
| a) $\text{dog } 3$ | g) $\text{dog } 7 + \text{dog } 3$ | m) $\text{dog } (5) \cdot 3$ |
| b) $\text{dog } 4$ | h) $\text{dog } (7) + \text{dog } 3$ | n) $3 \text{ dog } 5$ |
| c) $\text{dog } (7 + 3)$ | i) $\text{dog } (7) + \text{dog } (3)$ | o) $\text{dog } 4^2$ |
| d) $\text{dog } 7 + 3$ | j) $7 + 3$ | p) $\text{dog}^2 4$ |
| e) $\text{dog } (7) + 3$ | k) $\text{dog } 5 \cdot 3$ | q) $\text{dog } (4^2)$ |
| f) $3 + \text{dog } 7$ | l) $\text{dog } (5 \cdot 3)$ | r) $(\text{dog } 4)^2$ |

7. **NC** Let $\text{boat } x = 4x - 1$. Compute each quantity:

- | | |
|------------------------|--|
| a) $\text{boat } 2$ | d) $2 \text{ boat }^3 1$ |
| b) $3 \text{ boat } 4$ | e) $4 \text{ boat } 5 + \text{boat}^2 2$ |
| c) $\text{boat}^2 3$ | f) $\text{boat}^2 3^3$ |

8. a) If you know $\text{tag } x = 4$, does the expression $\text{tag } x - 3$ simplify? If so, how?
 b) If you know $x = 4$, does the expression $\text{tag } x - 3$ simplify? If so, how?
 c) If you know $\text{tag } x = 4$, does the expression $\text{tag } (x - 3)$ simplify? If so, how?
 d) If you know $x = 4$, does the expression $\text{tag } (x - 3)$ simplify? If so, how?
9. a) If you know $x = 2$, does the expression $\text{pop } x - 3 \text{ pop } (x + 1)$ simplify? If so, how?
 b) If you know $\text{pop } x = 2$, does the expression $\text{pop } x - 3 \text{ pop } (x + 1)$ simplify? If so, how?
 c) If you know $\text{pop } x = 2$ and $\text{pop } (x + 1) = 5$, does the expression $\text{pop } x - 3 \text{ pop } (x + 1)$ simplify? If so, how?
 d) If you know $x = 2$, does the expression $\text{pop }^2 x + 1$ simplify? If so, how?
 e) If you know $\text{pop } x = 2$, does the expression $\text{pop }^2 x + 1$ simplify? If so, how?
 f) If you know $\text{pop }^2 x = 2$, does the expression $\text{pop }^2 x + 1$ simplify? If so, how?
 g) If you know $\text{pop }^2 x = 2$, does the expression $\text{pop }^2 (x + 1)$ simplify? If so, how?

10. a) Substitute $x = \frac{2}{3}$ into the equation in $x + \text{out } x = 2$.
- b) Substitute in $x = \frac{2}{3}$ into the equation in $x + \text{out } x = 2$, and solve for out x .
- c) Substitute in $x = \frac{2}{3}$ into the equation in $^2x + \text{out } ^2x = 2$, and solve for out x .
- d) Substitute in $^2x = \frac{2}{3}$ into the equation in $^2x + \text{out } ^2x = 2$, and solve for out x .

Answers

- (a), (c) and (e) are functions.
 - $h(x) = 10x - 15$;
 $h(6) = 45$.
 - $f(2) = \boxed{5}$
 - $g(-3) = \boxed{10}$
 - $4f\left(\frac{2}{3}\right) = 4(1) = \boxed{4}$
 - $g(t) = \boxed{t^2 + 1}$
 - $f(1) = \boxed{-1}$
 - $f(-3) = \boxed{-9}$
 - $f(1 - 2) = f(-1) = \boxed{-5}$
 - $f(1) - f(2) = -1 - 1 = \boxed{-2}$
 - $f(1) + f(-2) = -1 + (-7) = \boxed{-8}$
 - $f(1) - 2 = -1 - 2 = \boxed{-3}$
 - $g(3) = \boxed{6}$
 - $g(2 \cdot 3) = g(6) = \boxed{30}$
 - $2g(3) = 2(6) = \boxed{12}$
 - $\text{dog } 3 = \boxed{4}$
 - $\text{dog } 4 = \boxed{3}$
 - $\text{dog } (7 + 3) = \text{dog } 10 = \boxed{9}$
 - $\text{dog } 7 + 3 = 8 + 3 = \boxed{11}$
 - $\text{dog } (7) + 3 = 8 + 3 = \boxed{11}$
 - $3 + \text{dog } 7 = 3 + 8 = \boxed{11}$
- $3 + g(6) = 3 + 37 = \boxed{40}$
 - $f(2x) = \boxed{6x - 1}$
 - $f(5) + g(5) = 14 + 26 = \boxed{40}$
 - $f(3) - g(4) = 8 - 17 = \boxed{-9}$
 - $1 - f(2) = 1 - 1 = \boxed{0}$
 - $2f(4) = 2(5) = \boxed{10}$
 - $f(2)4 = 1 \cdot 4 = \boxed{4}$
 - $4f(2) = 4 \cdot 1 = \boxed{4}$
 - $f(2 \cdot 4) = f(8) = \boxed{13}$
 - $2f(3) - 5f(1) = 2(3) - 5(-1) = \boxed{11}$
 - $g(-2 + 4) = g(2) = \boxed{2}$
 - $g(-2) + 4 = 6 + 4 = \boxed{10}$
 - $g(-2 \cdot 5) - 20 = g(-10) - 20 = 110 - 20 = \boxed{90}$
 - $\text{dog } 7 + \text{dog } 3 = 8 + 4 = \boxed{12}$
 - $\text{dog } (7) + \text{dog } 3 = 8 + 4 = \boxed{12}$
 - $\text{dog } (7) + \text{dog } (3) = 8 + 4 = \boxed{12}$
 - $7 + 3 = \boxed{10}$
 - $\text{dog } 5 \cdot 3 = \text{dog } 15 = \boxed{16}$
 - $\text{dog } (5 \cdot 3) = \text{dog } 15 = \boxed{16}$

8.1. Chapter 1 Homework

- m) $\text{dog } (5) \cdot 3 = 6 \cdot 3 = \boxed{18}$
- n) $3 \text{ dog } 5 = 3 \cdot 6 = \boxed{18}$
- o) $\text{dog } 4^2 = \text{dog } 4 \cdot 4 = \text{dog } 16 = \boxed{15}$
- p) $\text{dog}^2 4 = (\text{dog } 4)^2 = 3^2 = \boxed{9}$
- q) $\text{dog } (4^2) = \text{dog } 16 = \boxed{15}$
- r) $(\text{dog } 4)^2 = 3^2 = \boxed{9}$
7. a) $\text{boat } 2 = 4(2) - 1 = \boxed{7}$
- b) $3 \text{ boat } 4 = 3[4(4) - 1] = 3[15] = \boxed{45}$
- c) $\text{boat}^2 3 = (\text{boat } 3)^2 = (11)^2 = \boxed{121}$
- d) $2 \text{ boat }^3 1 = 2(\text{boat } 1)^3 = 2(3)^3 = 2(27) = \boxed{54}$
- e) $4 \text{ boat } 5 + \text{boat}^2 2 = 4[4(5) - 1] + (\text{boat } 2)^2 = 4[19] + 7^2 = 76 + 49 = \boxed{125}$
- f) $\text{boat}^2 3^3 = \text{boat}^2 9 = (\text{boat } 9)^2 = (35)^2 = \boxed{1225}$
8. a) $\text{tag } x - 3 = 4 - 3 = \boxed{1}$
- b) $\boxed{\text{tag } 4 - 3}$
- c) Doesn't simplify
- d) $\boxed{\text{tag } 1}$
- e) $2^2 + 1 = \boxed{5}$
- f) $2 + 1 = \boxed{3}$
- g) Doesn't simplify
9. a) $\boxed{\text{pop } 2 - 3 \text{ pop } 3}$
- b) $\boxed{2 - 3 \text{ pop}(x + 1)}$
- c) $2 - 3(5) = \boxed{15}$
- d) $\boxed{\text{pop}^2 2 + 1}$
10. a) $\text{in } \frac{2}{3} + \text{out } \frac{2}{3} = 2$
- b) $\frac{2}{3} + \text{out } x = 2;$
 $\text{out } x = \frac{4}{3}$
- c) $(\frac{2}{3})^2 + \text{out }^2 x = 2;$
 $\text{out } x = \pm \frac{\sqrt{14}}{3}$
- d) $\frac{2}{3} + \text{out }^2 x = 2;$
 $\text{out } x = \pm \frac{2}{\sqrt{3}}$

8.2 Chapter 2 Homework

§2.2: Linear measurements

1. NC A ball begins at position 5 in on a number line, rolls forward and backward for a while, and ends up at position 2 in. What is the displacement of the ball?
2. Suppose the displacement of a projectile shot upwards is 72.35 ft.
 - a) If the projectile was launched at a height of 5.88 feet, what is its height after it is shot upwards?
 - b) If the projectile ends up at a height of 105.22 feet, what was its initial height?
3. A skier skis downhill at 95 feet per second.
 - a) How far does the skier ski in 35 seconds?
 - b) How long would it take the skier to ski 3000 feet?
4. A cheetah runs at a constant speed; in 5.5 seconds the cheetah runs 293.7 feet.
 - a) What is the velocity of the cheetah, in feet per second?
 - b) What is the velocity of the cheetah, in miles per hour?
 - c) How far will the cheetah run in 15 seconds?
 - d) How long will it take the cheetah to run one-tenth of a mile?
5.
 - a) Convert 12 m to centimeters.
 - b) Convert 17 miles per minute to feet per second.
6.
 - a) Convert 18 feet to meters, assuming 2.54 cm equals one inch.
 - b) Convert 42.5 lb ft to Newton meters, assuming 1 lb is 4.4482 Newtons and 2.54 cm is one inch.
7. A LEGO drawing unit (LDU) is used to measure the dimensions of LEGO creations in terms of the sizes of standard LEGO pieces. Other LEGO units of measurements are *bricks*, *plates* and *snots*. One brick equals 15 LDU, one plate equals 5 LDU, and one snot (yes, that's a thing) equals 3 LDU.
 - a) How many bricks equal 18 LDU?
 - b) How many snots equal 90 bricks?
 - c) How many plates equal 10 snots?
 - d) How many bricks per plate are there in 72 snots per brick?

8. An alien race measures distances in two units: jorts and kortcs; they measure time in two units: peas and queues. 270 jorts equals 19 kortcs, and 532 peas equals 37 queues.
- The distance between two alien homes is 12 kortcs. How many jorts is this distance?
 - If an alien spaceship travels at a speed of 2640 jorts per pea, what is its speed in jorts per queue?
 - If an alien crawls along its planet at a speed of 15 jorts per queue, what is its speed in kortcs per pea?

Answers

- | | |
|--------------------------------------|-------------------------|
| 1. -3 in | b) 1496 ft/sec |
| 2. a) 78.23 ft | 6. a) 5.486 m |
| b) 32.87 ft | b) 57.622 Nm |
| 3. a) 3325 ft | 7. a) 1.2 bricks |
| b) 31.58 sec | b) 450 snots |
| 4. a) 53.4 ft/sec | c) 6 plates |
| b) 36.41 mi/hr | d) 4.8 bricks per plate |
| c) 801 ft | 8. a) 170.526 jorts |
| d) .0027465 hr
(a.k.a. 9.887 sec) | b) 37958.9 jorts/queue |
| 5. a) 1200 cm | c) .0734 kortcs/pea |

§2.3: The coordinate plane

- NC Graph the of the following points on the same coordinate plane:
 $(0, 5)$ $(-3, -2)$ $(4, 2)$ $(-3, 0)$ $(1, -6)$ $(-2, 5)$ $(0, -2)$
- NC
 - What quadrant is the point $(2, -7)$ in?
 - What quadrant is the point $(-\sqrt{2}, -\sqrt{5})$ in?
 - If a point is located below the x -axis, what quadrant(s) might it be in?
 - If a point is located to the left of the y -axis, what quadrant(s) might it be in?
 - If a point has negative x -coordinate but positive y -coordinate, what quadrant(s) might it be in?

8. **NC** Determine the components of vector \mathbf{a} , if \mathbf{a} can be drawn so that it begins at $(3, 7)$ and ends at $(8, 9)$.
9. **NC** Use the picture of vector \mathbf{v} given in the figure below to answer the questions that follow.

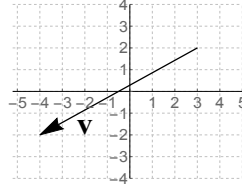

- What is the initial point of \mathbf{v} , as drawn above?
- What is the terminal point of \mathbf{v} , as drawn above?
- What are the components of \mathbf{v} ?
- If \mathbf{v} were drawn so that it started at $(3, 5)$, where would \mathbf{v} end?
- If \mathbf{v} were drawn so that its terminal point was $(-4, 0)$, where would its initial point be?

Answers

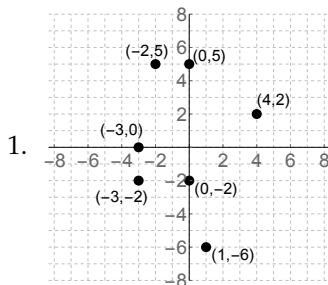

- IV
 - III
 - III or IV
 - II or III
 - II
 - I or III
 - the y -axis
- 5 units
 - 6 units
- $(-4, 7)$
 - $(4, -2)$
 - $(8, 1)$

d) $(-5, -3)$

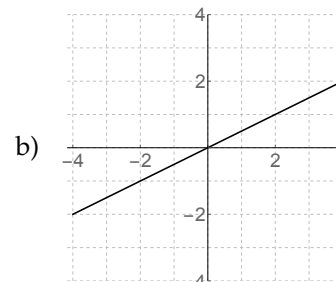
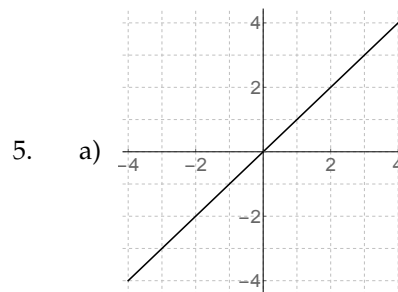

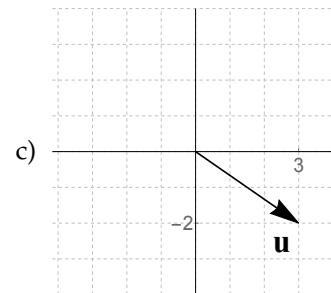
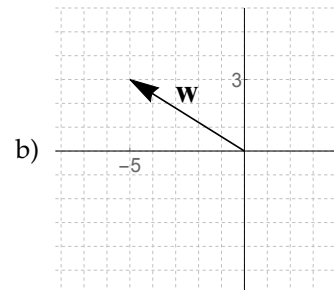
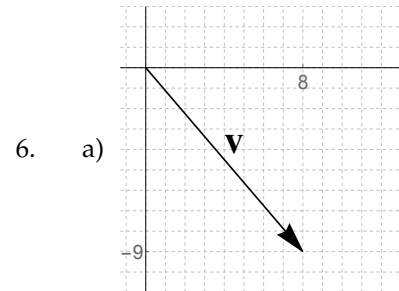
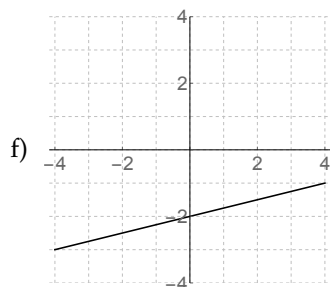
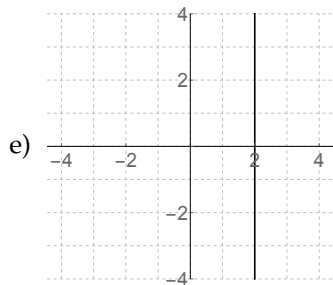
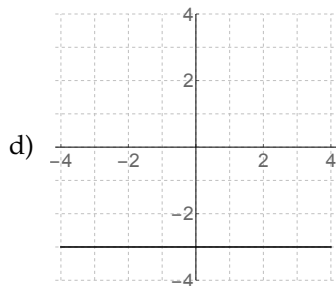
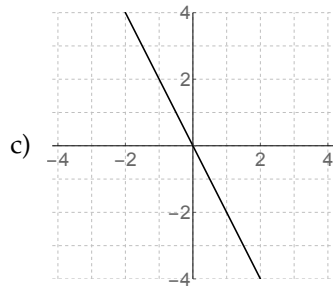

7. $\mathbf{w} = \langle 0, -8 \rangle$

8. $\mathbf{a} = \langle 5, 2 \rangle$

9. a) $\langle 3, 2 \rangle$

b) $\langle -4, -2 \rangle$

c) $\langle -7, -4 \rangle$

d) $\langle -4, 1 \rangle$

e) $\langle 3, 4 \rangle$

§2.4: Vector operations

1. A leaf is blown around on a concrete pad; at first, it is blown by the vector $\mathbf{v} = \langle 2.65, 4.92 \rangle$ and then by the vector $\mathbf{w} = \langle 9.33, 5.04 \rangle$.

a) What is the total displacement of the leaf?

b) Sketch a picture that represents the motion of the leaf in terms of vectors (assuming the leaf started out at the origin).

2. **NC** A caterpillar crawls around on an (x, y) -plane, starting at the point $(3, 8)$. The caterpillar moves first by the vector $\langle 2, -5 \rangle$, then by the vector $\langle 1, 4 \rangle$, and then by the vector $\langle -6, 3 \rangle$.
- Sketch a picture that represents the caterpillar's motion.
 - Where does the caterpillar end up?
 - What is the total displacement of the caterpillar?
 - If the caterpillar started at the origin and moved the same way, where would it end up?
 - If the caterpillar started at the point $(-5, -4)$ and moved the same way, where would it end up?
 - If the caterpillar moved in this way and ended up at the point $(7, 0)$, where would it have to have started?
3. **NC** Compute each indicated quantity. Then, draw a picture to illustrate what you have just computed:
- $\langle 7, 3 \rangle + \langle 2, 9 \rangle$
 - $\frac{2}{3} \langle 4, -3 \rangle$
 - $2 \langle -5, -6 \rangle$
 - $-\langle -3, 5 \rangle$
 - $3 \langle 1, 2 \rangle - 4 \langle 0, 2 \rangle$
 - $-3 \langle 10, -3 \rangle + \langle 9, 5 \rangle$
4. **NC** Throughout this problem, let $\mathbf{x} = \langle 2, -7 \rangle$, let $\mathbf{y} = \langle 5, 1 \rangle$ and let $\mathbf{z} = \langle -3, -2 \rangle$. Compute each indicated quantity:
- $4\mathbf{x}$
 - $-\mathbf{y}$
 - $\mathbf{x} + \mathbf{z}$
 - $3\mathbf{x} - 2\mathbf{y}$
 - $\mathbf{y} + \frac{1}{2}\mathbf{z}$
 - $\mathbf{x} - 2\mathbf{y} + \mathbf{z}$
5. Throughout this problem, let $\mathbf{i} = \langle 5.35, -2.18 \rangle$, let $\mathbf{j} = \langle 11.31, 14.59 \rangle$ and let $\mathbf{k} = \langle -9.82, 17.78 \rangle$. Compute each indicated quantity:
- $3.42\mathbf{j}$
 - $-.8\mathbf{k} + 3.2\mathbf{i}$
 - $2\mathbf{i} + 5\mathbf{j} - 7\mathbf{k}$
 - $1.6(\mathbf{i} + \mathbf{j}) - 5.7\mathbf{k}$
6. **NC** In this problem, consider the vectors \mathbf{u} , \mathbf{v} and \mathbf{w} pictured below, at left. Copy that picture of \mathbf{u} , \mathbf{v} and \mathbf{w} , and then sketch each of these vectors on that picture:
- $2\mathbf{u}$
 - $-\frac{3}{2}\mathbf{v}$
 - $\frac{1}{4}\mathbf{w}$
 - $\mathbf{u} + \mathbf{w}$
 - $3\mathbf{u} - \mathbf{v}$
 - $2\mathbf{u} + \mathbf{v} - \mathbf{w}$

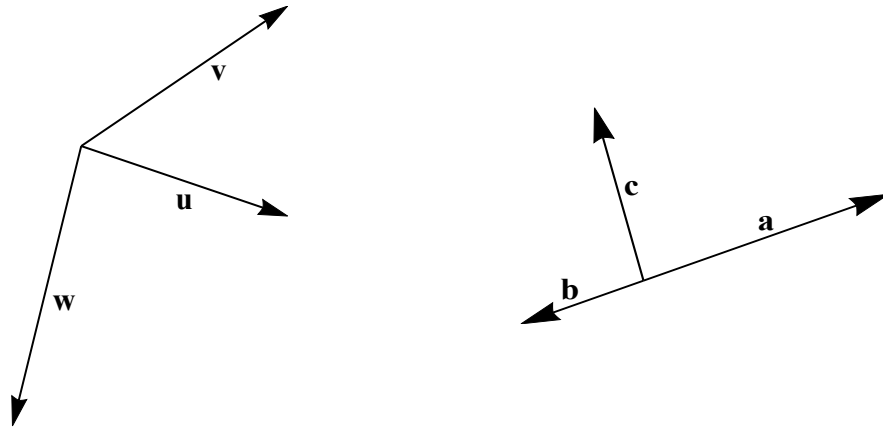

7. **NC** In this problem, consider the vectors \mathbf{a} , \mathbf{b} and \mathbf{c} pictured above, at right. Copy that picture of \mathbf{a} , \mathbf{b} and \mathbf{c} , and then sketch each of these vectors on that picture:

- | | | |
|------------------------------|-------------------------------|--------------------------------|
| a) $\frac{1}{3}\mathbf{b}$ | c) $\mathbf{a} + \mathbf{c}$ | e) $-2\mathbf{c}$ |
| b) $\mathbf{c} - \mathbf{a}$ | d) $\mathbf{a} + 2\mathbf{b}$ | f) $3\mathbf{b} - 2\mathbf{c}$ |

8. **NC** **OPT** In this problem, consider the vectors \mathbf{j} and \mathbf{k} shown on the next page. Copy that picture of \mathbf{j} and \mathbf{k} , and then sketch each of these vectors on that picture:

- | | |
|------------------------------|--|
| a) $\mathbf{j} + \mathbf{k}$ | e) $0\mathbf{k}$ |
| b) $\mathbf{k} - \mathbf{j}$ | f) $-\frac{1}{4}\mathbf{k}$ |
| c) $\mathbf{j} - \mathbf{k}$ | g) $2\mathbf{j} - \frac{2}{3}\mathbf{k}$ |
| d) $3\mathbf{j}$ | |

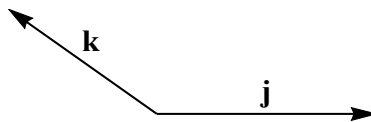

9. **NC** Compute each indicated dot product:

- | | |
|--|--|
| a) $\langle 2, -5 \rangle \cdot \langle 3, -1 \rangle$ | c) $\langle 0, 8 \rangle \cdot \langle -3, -4 \rangle$ |
| b) $\langle -1, 7 \rangle \cdot \langle 4, 2 \rangle$ | d) $\langle 3, 4 \rangle \cdot \langle 8, 1 \rangle$ |

10. Throughout this problem, let $\mathbf{u} = \langle 1.3, -1.5 \rangle$, let $\mathbf{v} = \langle 2.5, .7 \rangle$ and let $\mathbf{w} = \langle 3.1, -.2 \rangle$. Compute each indicated quantity:

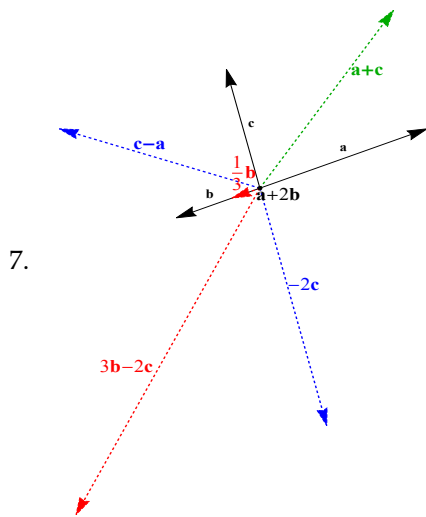
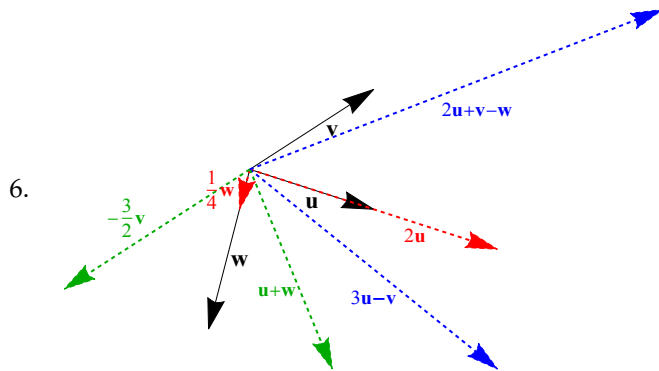

Note: in part (d) of # 7, $a + 2b$ is the zero vector, so there's nothing to draw there except the point at the origin.

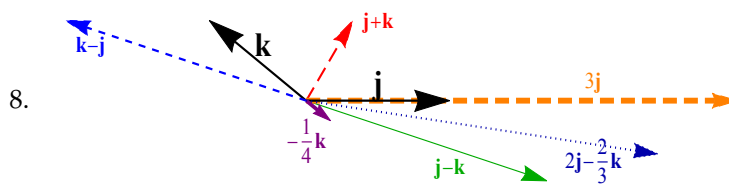

Note: in part (e) of # 8, $0k$ is the zero vector, so there's nothing to draw there except the point at the origin.

- | | | | | |
|-----|----------|--------------|-------------|----------|
| 9. | a) 11 | b) 10 | c) -32 | d) 28 |
| 10. | a) 4.33 | b) 6.6 | c) -5.8 | d) 44.65 |
| 11. | $a = 10$ | 12. 1147.5 J | 13. 45066 J | |

§2.5: Angles

- Convert 3.8275 revolutions to degrees.
 - Convert 1055° to revolutions.
 - Convert -157° to revolutions.
- A **grad** is another unit of angle measure, defined so that there are 100 grads in a right angle.
 - How many grads are there in one revolution?
 - Convert 295.3° to grads.
 - Convert 735.8 grads to revolutions.
- Suppose you rotate clockwise by 35° , then counterclockwise by 20° . What is the total measure of your rotation (in degrees)?
- Compute the measure of angle α , in the picture below at left.
 - If α is as in part (a), what is the measure of $-\alpha$?
 - Compute the measure of angle θ , in the middle picture below.
 - If θ is as in part (c), what is the measure of 3θ ?
 - Compute the measure of angle γ , in the picture below at right.
 - If γ is as in part (e), what is the measure of $\frac{5}{2}\gamma - 75^\circ$?
 - If γ is as in part (e) and $\gamma + \delta$ makes one revolution, what is δ ?

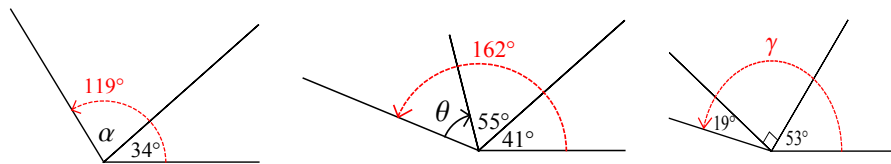

- Angles θ and β are supplementary. If $\alpha = 26^\circ$, what is the measure of β ?
- Angles θ_1 and θ_2 are complementary. If $\theta_1 = 53^\circ$, what is the measure of $\theta_1 - \theta_2$?
- What is the measure of the complement of a 90° angle?
- What is the measure of the complement of 120° angle? How about the supplement of a 324° angle?

9. In the picture below at left, compute x .

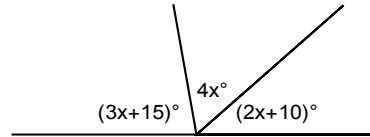
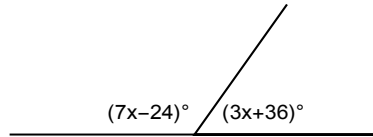

10. In the picture above at right, compute the measures of the three angles shown.

11. Angles $(4x - 19)^\circ$ and $(2x - 23)^\circ$ are supplementary. Compute x .

12. This figure shows a slanted walkway with a handrail. θ is the angle between the walkway and the horizontal, and ϕ ("phi") is the angle between the walkway and a beam that holds up the handrail.

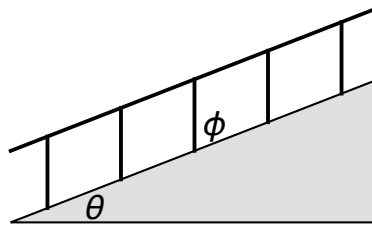

- Are θ and ϕ complementary?
 - Are θ and ϕ supplementary?
 - If $\theta = 16^\circ$, what is the measure of ϕ ?
13. Suppose that a gear rotates at 12 rpm (revolutions per minute).
- What is its angular velocity in degrees per second?
 - Through what angle does the gear rotate in .325 seconds?
 - How long does it take the gear to rotate through an 116° angle?
14. A flywheel rotates through an angle of 850° every 3 seconds.
- What is its angular velocity, in degrees per second?
 - Through what degree does the flywheel rotate in 40 seconds?
 - How long does it take the flywheel to rotate through 45° ?
 - How many revolutions does the flywheel make in 2 minutes?
15. NC Determine whether the given angle is acute, obtuse, right or reflex:

- a) 57° c) 90° e) 259°
 b) 128° d) $35^\circ + 28^\circ + 44^\circ$ f) 36°

16. NC Determine which one or ones of the following angles is quadrantal:

- a) 60° c) 450° e) 240°
 b) 0° d) 330° f) 270°

Answers

1. a) 1377.9°
 b) 2.93 rev
 c) $-.436$ rev
2. a) 400 grads
 b) 328.111 grads
 c) 1.8395 rev
3. -15°
4. a) $\alpha = 85^\circ$
 b) $-\alpha = -85^\circ$
 c) $\theta = -66^\circ$
 d) $3\theta = -198^\circ$
 e) $\gamma = 162^\circ$
 f) $\frac{5}{2}\gamma - 75^\circ = 330^\circ$
 g) $\delta = 198^\circ$
5. $\beta = 154^\circ$
6. $\theta_1 - \theta_2 = 16^\circ$
7. 0°
8. $-30^\circ; -144^\circ$
9. $x = 16.8^\circ$
10. $66.666^\circ, 68.888^\circ$ and 44.444°
11. $x = 37^\circ$
12. a) Yes
 b) No
 c) $\phi = 74^\circ$
13. a) $72^\circ/\text{sec}$
 b) 23.4°
 c) 1.611 sec
14. a) $283.333^\circ/\text{sec}$
 b) 11333.3°
 c) .1588 sec
 d) 94.44 rev
15. a) acute
 b) obtuse
 c) right
 d) obtuse
 e) reflex
 f) acute
16. (b), (c), and (f) are quadrantal.

§2.6: Solving angle pictures

- In the picture below at left, find the value of x , and find the measure of the angle marked θ .

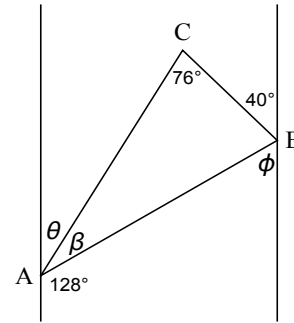
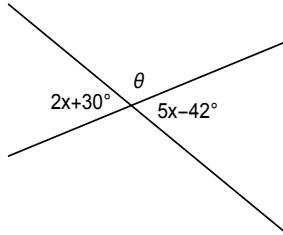

- In the picture above at right, assume the two lines that look vertical are actually vertical, and assume that the distance from A to C is the same as the distance from A to B. Find the measures of the angles marked θ , β (this is "beta") and ϕ (this is "phi"):
- In the picture below at left, assume lines l and m are parallel. Find the measures of the angles marked α , β and δ (these are "alpha", "beta" and "delta"):

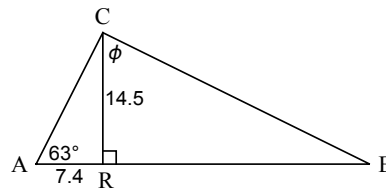
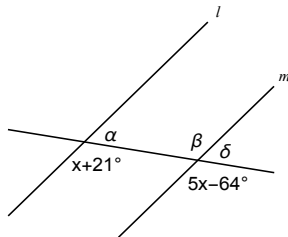

- In the picture above at right, assume lines AC and BC are perpendicular.
 - Find the measure of the angle marked ϕ .
 - Find the measure of angle B .
- In each picture, find the measure of the angle marked A:

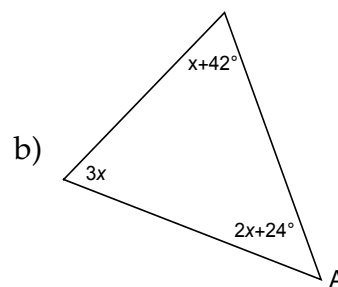
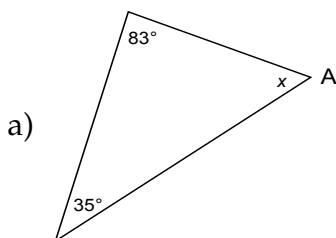

6. One angle of a triangle measures 125° . The other two angles differ in measure by 17° . What is the measure of the smallest angle of this triangle?
7. Two angles of a triangle are of equal measure. The third angle is one-third the measure of each of the other two. What are the measures of the angles of this triangle?
8. In each part of this problem, you are given the side lengths of the three sides in a triangle. Classify the triangle as equilateral, isosceles (meaning isosceles but not equilateral), or scalene:
- a) $a = 14, b = 12, c = 11$ b) $a = 9, b = 7, c = 9$
9. In each part of this problem, you are given the angle measures of two of the three angles in a triangle. Classify the triangle as equilateral, isosceles (meaning isosceles but not equilateral), or scalene:
- a) $A = 72^\circ, B = 36^\circ$ b) $A = 44^\circ, B = 82^\circ$

Answers

- | | | |
|---|---|---|
| 1. $x = 24^\circ;$
$\theta = 102^\circ$ | $\delta = 137.75^\circ;$
$\beta = 42.25^\circ$ | 6. 19° |
| 2. $\beta = 28^\circ;$
$\theta = 24^\circ;$
$\phi = 64^\circ$ | 4. a) $\phi = 63^\circ$
b) $\angle B = 27^\circ$ | 7. $77.14^\circ, 77.14^\circ$ and 25.72° |
| 3. $\alpha = 137.75^\circ;$ | 5. a) 62°
b) 62° (x is 19°) | 8. a) isosceles
b) scalene |
| | | 9. a) isosceles
b) scalene |

§2.7: Pythagorean Theorem

1. In each part of this problem, you are given the angle measures of two of the three angles in a triangle. Classify the triangle as acute, right or obtuse:
- a) $A = 105^\circ, C = 18^\circ$ c) $A = 44^\circ, B = 37^\circ$
 b) $B = 82^\circ, C = 30^\circ$ d) $Q = 28^\circ, R = 62^\circ$
2. In each triangle shown below, determine the distance marked with a “?”:

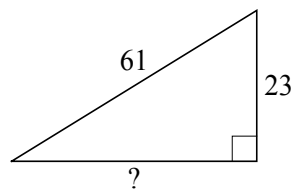
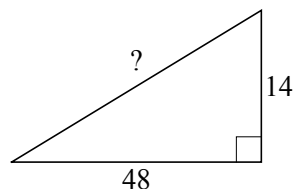

3. **NC** In each triangle shown below, determine the distance marked with a "?":

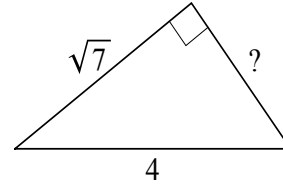
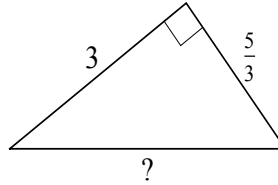
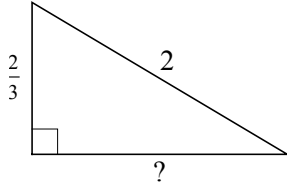

4. In the figure from Exercise 4 from the homework exercises from Section 2.6, find AC (this is the distance from A to C).
5. a) The two legs of a right triangle measure 12.5 and 19.3 inches. Compute the length of the hypotenuse.
 b) A right triangle has one leg of length 80 ft and a hypotenuse of 92 ft. Compute the length of the other leg.
6. In each part of this problem, you are given the lengths of the three sides of a triangle. Classify the triangle as acute, right or obtuse.
- a) $a = 19.3, b = 40.7, c = 45.8$ c) $x = 133, y = 205, z = 241$
 b) $p = 16.5, q = 22, r = 27.5$ d) $g = .31, h = .43, i = .55$
7. Compute the magnitude of $\langle -6, 11 \rangle$. Then, draw a picture to illustrate what you have just computed.
8. Let $\mathbf{w} = \langle 8, 5.5 \rangle$. Compute $|\mathbf{w}|$, and then draw a picture to illustrate what you have just computed.
9. Compute the magnitude of the vector $\mathbf{v} = \langle 6.35, -2.84 \rangle$.
10. Let $\mathbf{v} = \langle -13.75, -19.2 \rangle$. Compute $|\mathbf{v}|$.
11. **NC** If $|\mathbf{v}| = 3$, what is $|4\mathbf{v}|$? What about $|-6\mathbf{v}|$? What about $|\frac{1}{2}\mathbf{v}|$?

Answers

1. a) obtuse b) right c) acute d) obtuse
2. 50; 56.5 3. $\frac{\sqrt{32}}{3}; \frac{\sqrt{106}}{3}; 3$ 4. 16.279

5. a) 22.994 in

b) 45.431 ft

6. a) acute

b) right

c) obtuse

d) acute

7. $\sqrt{157} = 12.53$

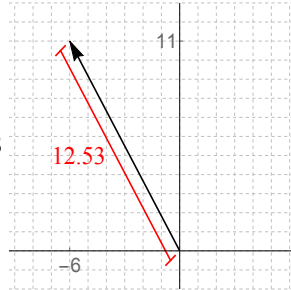

8. $|\mathbf{w}| = 9.708$

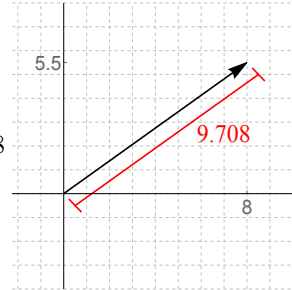

9. $|\mathbf{v}| = 6.956$

10. $|\mathbf{v}| = 23.616$

11. $|4\mathbf{v}| = 12; |-6\mathbf{v}| = 18; \left|\frac{1}{2}\mathbf{v}\right| = \frac{3}{2}$.

§2.8: Standard position of an angle

1. NC Sketch each of these angles in standard position:

a) 70°

c) 152°

e) -750°

g) -5°

b) -105°

d) 402°

f) 270°

h) 280°

2. NC Estimate the measure (in degrees) of each of these angles:

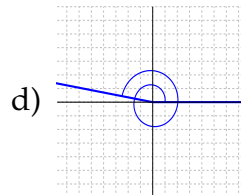
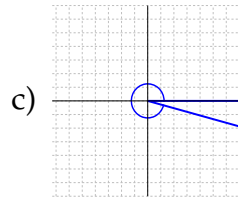
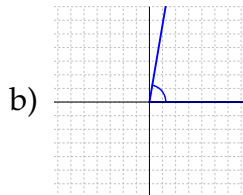
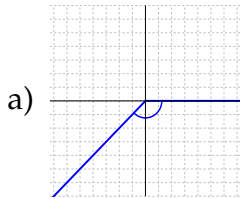

- b) Find an angle in Quadrant II that is symmetric with -63° .
c) Find an angle in Quadrant III that is symmetric with 105° .
d) Find an angle in Quadrant I that is symmetric with 299° .
9. For each given angle, find four angles, one in each quadrant, that are symmetric with the given angle:
- a) 152° b) 299° c) -123° d) 16°
10. [NC] Suppose $(4, -5)$ is a point on the terminal side of θ , when θ is drawn in standard position.
- a) What are the coordinates of a point on the terminal side of $180^\circ - \theta$?
b) What quadrant is $-\theta$ in?
c) What are the coordinates of a point on the terminal side of $\theta + 180^\circ$?
d) What quadrant is $\theta - 180^\circ$ in?
e) What are the coordinates of a point on the terminal side of $360^\circ - \theta$?
f) What quadrant is $\theta + 720^\circ$ in?
g) What are the coordinates of a point on the terminal side of $360^\circ + \theta$?
h) What angle, in terms of θ , is the point $(4, 5)$ on the terminal side of?
11. [NC] Suppose (x, y) is a point on the terminal side of angle θ , when θ is drawn in standard position. For each angle given below, give the coordinates (in terms of x and/or y) of a point on the terminal side of that angle:
- a) $-\theta$ c) $360^\circ - \theta$ e) $180^\circ + \theta$ g) $540^\circ + \theta$
b) $180^\circ - \theta$ d) $540^\circ - \theta$ f) $360^\circ + \theta$ h) $720^\circ + \theta$
12. For each given angle, compute its reference angle.
- a) 152° b) 292° c) 251°
13. [NC] Suppose $(-8, 3)$ is on the terminal side of β , when θ is drawn in standard position.
- a) What quadrant is β in?
b) What are the coordinates of a point on the terminal side of $90^\circ - \beta$?
c) What quadrant is $90^\circ - \beta$ in?
d) What are the coordinates of a point on the terminal side of $180^\circ - \beta$?

- e) What are the coordinates of a point on the terminal side of $270^\circ - \beta$?
14. **NC** Suppose that $(3, 4)$ is on the terminal side of a 53.1° angle, when that angle is drawn in standard position.
- a) For what angle θ is $(3, -4)$ on the terminal side of θ ?
 - b) For what angle θ is $(-3, 4)$ on the terminal side of θ ?
 - c) For what angle θ is $(4, 3)$ on the terminal side of θ ?
 - d) For what angle θ is $(-4, -3)$ on the terminal side of θ ?

Answers

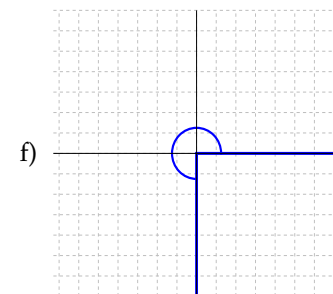
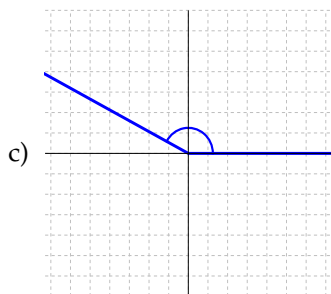
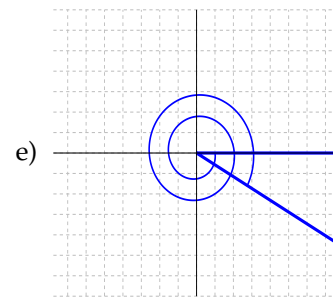
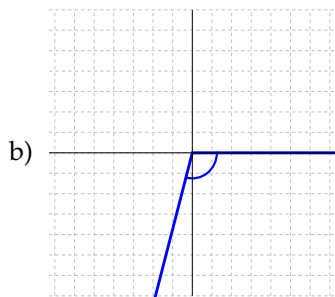
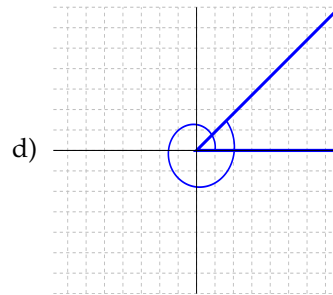
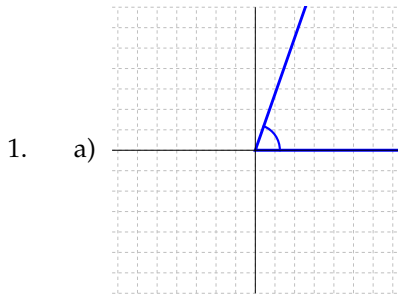

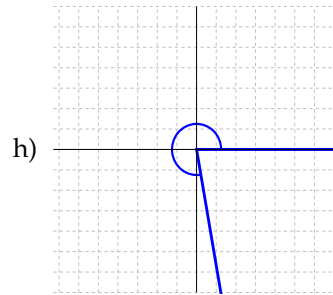
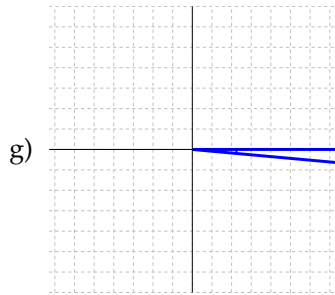

2. a) -135° b) 80°

- c) 345° d) 530°

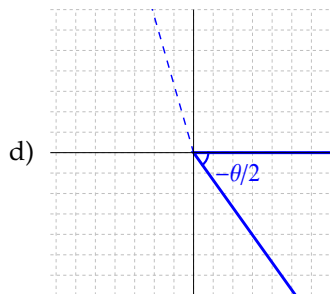
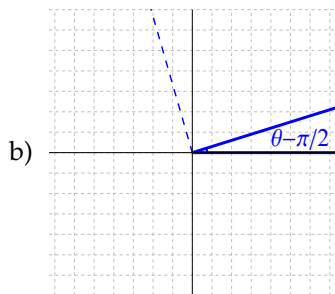
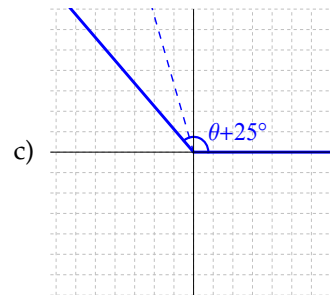
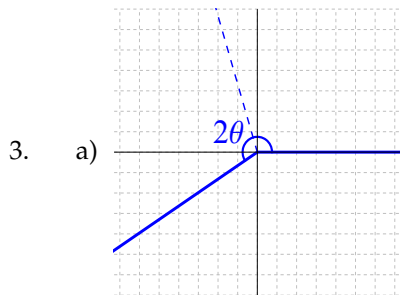

4. Answers can vary here; anything close to any multiple of what I wrote is fine.

- a) $(-9.5, 9)$ b) $(5, -2)$

5. Answers can vary here; anything close to any multiple of what I wrote is fine.

- a) $(-3, -4)$ b) $(-7, 1)$ c) $(-7, 10)$ d) $(-7, 1)$

6. a) 333° 8. a) 10°
 b) 245° b) 117°
 c) 244° c) 255°
 d) 61°

7. Answers may vary here:

- a) $777^\circ, 57^\circ, -303^\circ$ 9. a) $28^\circ, 152^\circ, 208^\circ, 332^\circ$
 b) $45^\circ, 405^\circ, -315^\circ$ b) $61^\circ, 119^\circ, 241^\circ, 299^\circ$
 c) $-420^\circ, 300^\circ, 660^\circ$ c) $57^\circ, 123^\circ, 237^\circ, 303^\circ$
 d) $-20000^\circ, 160^\circ, -200^\circ$ d) $16^\circ, 164^\circ, 196^\circ, 344^\circ$
 10. a) $(-4, -5)$

- b) I
c) $(-4, 5)$
d) II
e) $(4, 5)$
f) IV
g) $(4, -5)$
h) $-\theta$ ($360^\circ - \theta$ is also OK)
11. a) $(x, -y)$
b) $(-x, y)$
c) $(x, -y)$
d) $(-x, y)$
e) $(-x, -y)$
f) (x, y)
g) $(-x, -y)$
- h) (x, y)
12. a) 28°
b) 68°
c) 71°
13. a) II
b) $(3, -8)$
c) IV
d) $(8, 3)$
e) $(-3, 8)$
14. a) -53.1° (306.9° is also OK)
b) 126.9°
c) 36.9°
d) 216.9°

§2.9: Radian measure

- Suppose $(\frac{7}{18}, y)$ is a point on the unit circle. Find all possible values of y (in this question, no decimals are allowed: give exact answers).
- Suppose $(x, -.396)$ is a point on the unit circle. Find all possible values of x (here, decimal approximations based on correct algebra are OK).
- Find the coordinates of all the points where the line $y = x$ intersects the unit circle.
- Find the coordinates of all the points where the line $y = -2x$ intersects the unit circle.
- For each given angle, find the coordinates of a point on the unit circle at that angle:

a) 90°	c) 135°	e) 225°	g) -45°
b) -450°	d) -180°	f) 360°	h) 270°
- Compute the circumference of a circle of radius 3.8 cm.
- NC In each picture below, you are given an angle, drawn in standard position, together with a circle of radius 1. Use the picture to estimate the radian

measure of the angle (your answer should be estimated to the nearest $\frac{1}{2}$ radian):

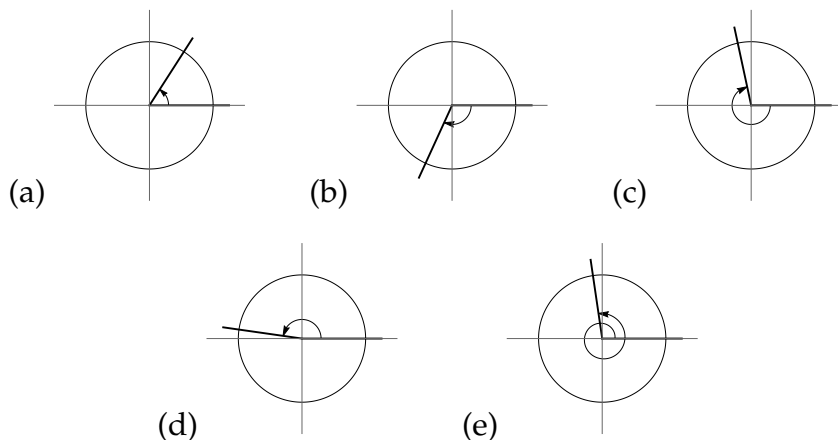

8. Convert each given angle to radians (a decimal approximation is fine):

- a) 238.55° b) 23° c) -127.75° d) 80°

9. Convert each given angle to degrees (a decimal approximation is fine):

- a) 2.784 b) -5.182 c) 1.65 d) 14.3

10. **NC** For each angle, draw the angle in standard position. Then convert the angle to radians, giving an exact answer:

- a) 300° c) -90° e) -120° g) 1080°
 b) 60° d) 225° f) 135° h) 210°

11. **NC** For each given angle, draw the angle in standard position. Then convert the angle to degrees, giving an exact answer:

- a) $\frac{5\pi}{3}$ c) $\frac{-5\pi}{6}$ e) -17π g) $\frac{-2\pi}{3}$
 b) $\frac{\pi}{4}$ d) $\frac{19\pi}{2}$ f) $\frac{\pi}{6}$ h) $\frac{13\pi}{2}$

12. An angle measures exactly four and one-eighth revolutions and is measured counterclockwise. Convert this angle to degrees and radians (decimal approximations are fine here).

13. An angle measures two and one-fifth revolutions and is measured clockwise. Compute the exact number of degrees in this angle.

11. I'm leaving off the pictures here (after converting to degrees, they are similar to # 1 from Section 2.8) and just giving the conversions to degrees:

a) $\frac{5\pi}{3} = 300^\circ$

b) $\frac{\pi}{4} = 45^\circ$

c) $\frac{-5\pi}{6} = -150^\circ$

d) $\frac{19\pi}{2} = 1710^\circ$

e) $-17\pi = -3060^\circ$

f) $\frac{\pi}{6} = 30^\circ$

g) $\frac{-2\pi}{3} = -120^\circ$

h) $\frac{13\pi}{2} = 1170^\circ$

12. 1485° ; 25.91 radians

13. -792°

14. 4.2025 rev

15. a) 45°

b) 30°

c) 30°

d) 45°

e) 60°

f) 60°

16. a) 45°

b) 30°

c) 60°

d) 30°

e) 45°

f) 45°

g) 60°

h) 60°

i) 60°

§2.10: Applications of radian measure

- Suppose the area of a circle is 15.85 square feet. Compute the radius of the circle.
- Compute the length of a circular arc taken from a circle of radius 18 in, where the central angle of the arc is 132.5° .
- Compute the length of a circular arc taken from a circle of radius 19.2 mm, where the central angle of the arc is 1.85 radians.
- Compute the area of a circular sector taken from a circle of diameter 225 m, where the central angle of the sector is 18.25° .
- Suppose a circular sector has radius 14.8 inches and has area 115.7 square inches. What is the measure of the central angle of this sector?
- A rope is being wound around a spool with a radius of 9 inches. How much rope will be wound around the spool if the spool is rotated through an angle of 262° ?
- The minute hand on a clock is 3.2 inches long. Assuming the clock works properly, what is the distance travelled by the tip of the minute hand between noon and 4 : 45 PM?

8. Dr. McClendon's siblings are corn farmers who irrigate their land with a center-pivot irrigation system (Google this if you don't know what it is). If one of their sprinklers has length 800 feet, and swings through an angle of 205° , what is the area of the land that this sprinkler irrigates?
9. The video game character Pac-Man looks like this (when his mouth is open):

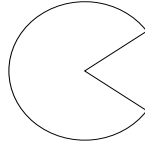

If the radius of Pac-Man is 3.5 cm and if Pac-Man's mouth opens at a 70° angle, find the perimeter and the area of Pac-Man.

10. A lighthouse has a rotating light that makes two full rotations per second. What is the angular velocity of the light beam, in radians per second?
11. Compute the angular velocity of a bird flying around in a circle, if the bird flies at 40 miles per hour and the radius of the bird's flight path is .003 mi.
12. Suppose that a point on a rotating circle of radius 173 mm travels 2158 mm in 3 seconds. What is the angular velocity of the circle, in radians per second?
13. A bug is sitting on the edge of a wheel that has diameter 18 in. If the wheel is rotating at 3.5 revolutions per minute, what is the linear velocity of the bug? How far does the bug travel in 12 minutes?
14. Two gears are interlocked like the picture in Example 46 of Chapter 2 of my lecture notes; in this problem, the smaller gear has radius 3.5 in and the larger gear has radius 7.25 in. Suppose that the smaller gear is rotated at 75 rpm (revolutions per minute).
- What is the angular velocity of the smaller gear, in radians per minute?
 - What is the linear velocity of the smaller gear?
 - What is the linear velocity of the larger gear?
 - What is the angular velocity of the larger gear, in radians per minute?
 - What is the angular velocity of the larger gear, in revolutions per minute?
15. A bicycle works because of a chain that attaches a gear that is pedaled to a gear that turns a wheel of the bicycle. Suppose the radius of the gear attached to the pedal is 1.4 in, and the radius of the gear attached to the wheel is 5.2 in, and that the radius of the bicycle wheel is 20 in.

- a) If you pedal the bicycle at 1 revolution per second, how fast will the bicycle go (i.e. what will the linear velocity of the bike be)?
- b) If you rotate the pedals of the bicycle by 1000° , how far will the bicycle go?

Answers

1. 2.25 ft
2. 41.63 in
3. 35.52 mm
4. 17.9169 m^2
5. 60.53°
6. 41.155 in
7. 95.504 in
8. 1144936 sq ft
9. perimeter = 24.71 cm;
area = 31 cm^2
10. $4\pi \approx 12.566 \text{ rad/sec}$
11. 13333.3 rad/hr
12. 4.16 rad/sec
13. $v = 197.92 \text{ in/min}$;
the bug travels 2375.04 in in 12 min
14. a) 471.239 rad/min
b) 1649.34 in/min
c) 1649.34 in/min
(same as the smaller gear)
d) 227.5 rad/min
e) 4.994 rpm
15. a) 33.8325 in/sec
b) 29.5245 in

8.3 Chapter 3 Homework

§3.1: Unit circle definitions

1. **NC** Compute the exact value of each quantity:

- | | | | |
|---------------------------|----------------------------|----------------------|---------------------------|
| a) $\sin \frac{\pi}{2}$ | f) $\tan 90^\circ$ | k) $\tan 0$ | p) $\cos \frac{3\pi}{2}$ |
| b) $\sin 90^\circ$ | g) $\tan -5\pi$ | l) $\cos -9\pi$ | q) $\cos -180^\circ$ |
| c) $\cos \frac{-9\pi}{2}$ | h) $\cos 900^\circ$ | m) $\tan \pi$ | r) $\sin 450^\circ$ |
| d) $\cos 2\pi$ | i) $\sin \frac{-13\pi}{2}$ | n) $\sin -12\pi$ | s) $\tan \frac{-9\pi}{2}$ |
| e) $\cos 720^\circ$ | j) $\cos 270^\circ$ | o) $\tan -270^\circ$ | t) $\cos 630^\circ$ |

2. **NC** Compute the exact value of each quantity:

- | | |
|--|--|
| a) $3 - 2 \sin \frac{5\pi}{2}$ | f) $\sin 7\pi + \pi$ |
| b) $\cos 180^\circ - 4 \sin 0$ | g) $\sin 180^\circ - 4 \cos 90^\circ$ |
| c) $\tan \left(\pi + \frac{\pi}{2} \right)$ | h) $\cos \left(\frac{5\pi}{4} + \frac{5\pi}{4} \right)$ |
| d) $\sin -2\pi + \tan \frac{-\pi}{2}$ | i) $1 + 3 \tan^2 1440^\circ$ |
| e) $3 \sin^2 270^\circ$ | j) $\cos 360^\circ \tan 180^\circ$ |

3. **OPT NC** Compute the exact value of each quantity:

- | | | | |
|--------------------------|--------------------------|--------------------------|----------------------------|
| a) $\cos 3\pi$ | e) $\cos 4\pi$ | i) $\cos 450^\circ$ | m) $\sin \frac{-19\pi}{2}$ |
| b) $\tan 0^\circ$ | f) $\tan \frac{\pi}{2}$ | j) $\tan 540^\circ$ | n) $\cos -450^\circ$ |
| c) $\sin \frac{9\pi}{2}$ | g) $\sin -90^\circ$ | k) $\sin \frac{-\pi}{2}$ | o) $\cos \frac{15\pi}{2}$ |
| d) $\cos \frac{7\pi}{2}$ | h) $\tan \frac{3\pi}{2}$ | l) $\cos -270^\circ$ | p) $\sin 5\pi$ |

4. **OPT NC** Compute the exact value of each quantity:

- | | |
|------------------------------------|---|
| a) $\tan 10\pi \sin 630^\circ$ | e) $-\cos \pi - \sin^5 \frac{11\pi}{2}$ |
| b) $3 \sin^2 \frac{\pi}{2} - 5$ | f) $7 \tan -90^\circ$ |
| c) $\cos 0 - \tan \frac{-7\pi}{2}$ | g) $\cos \frac{-14\pi}{2} \sin \frac{8\pi}{2}$ |
| d) $\cos -5 \cdot \frac{\pi}{2}$ | h) $\tan \left(\frac{3\pi}{2} - \frac{\pi}{2} \right) - \pi$ |

5. **NC** In each part of this problem, you are given a picture of an angle, drawn in standard position. Use that picture to estimate the sine, cosine and tangent of that angle.

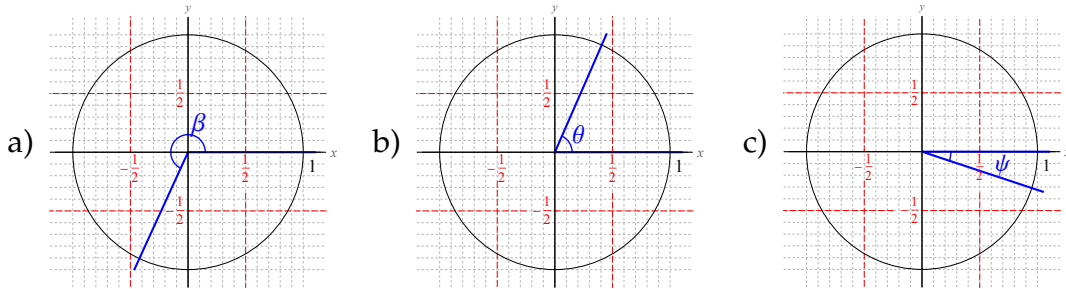

6. **NC** Estimate each quantity by drawing a picture of the angle in standard position.

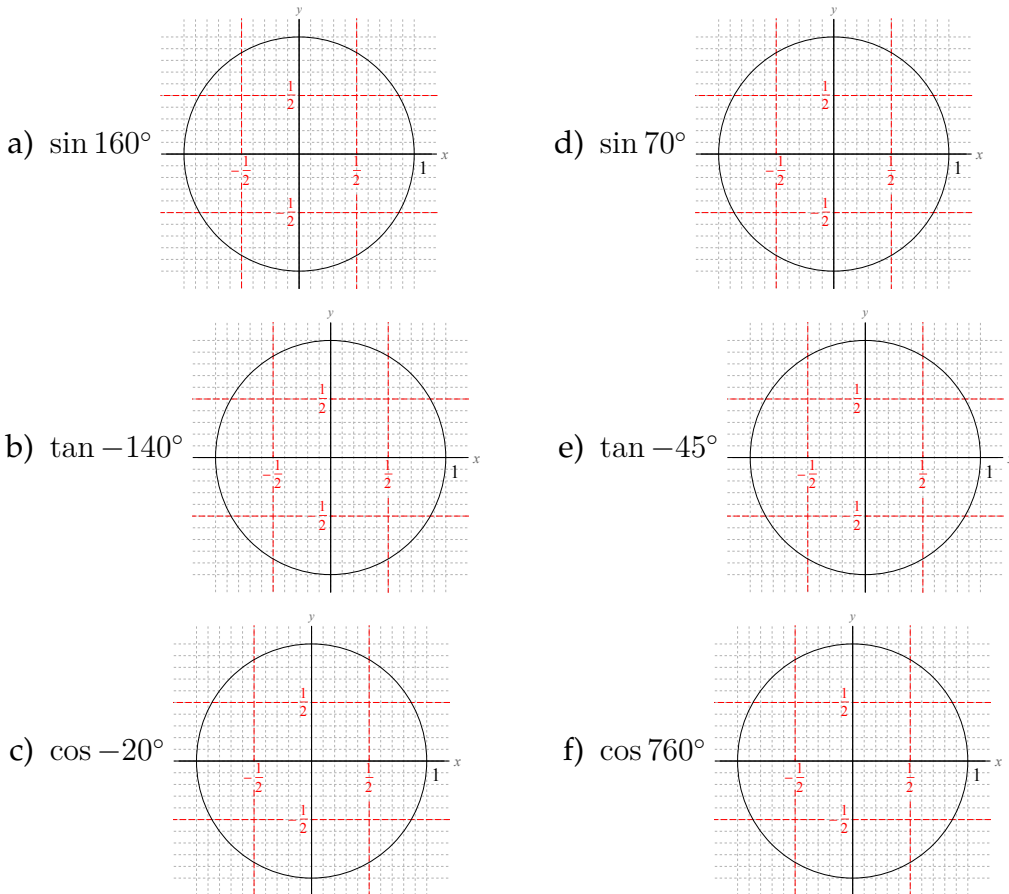

7. **NC** In each part of this problem, you are given a trig equation. If the equation has a solution, estimate the degree measure of two different angles between 0° and 360° that solve the equation. If the equation is not possible to solve, say so.

8.3. Chapter 3 Homework

- a) $\sin \theta = -1$ d) $\sin \theta = -0.85$ g) $\cos \theta = 0.8$ j) $\cos \theta = 20$
 b) $\tan \theta = -5$ e) $\sin \theta = -1.3$ h) $\tan \theta = 20$ k) $\tan \theta = 0.3$
 c) $\cos \theta = 0$ f) $\sin \theta = 0.9$ i) $\cos \theta = 0.6$ l) $\sin \theta = 0.3$

8. **NC** In each part of this problem, you are given a picture with a quantity marked with a "?". Write a formula for the "?" in terms of the angle(s) marked in the picture.

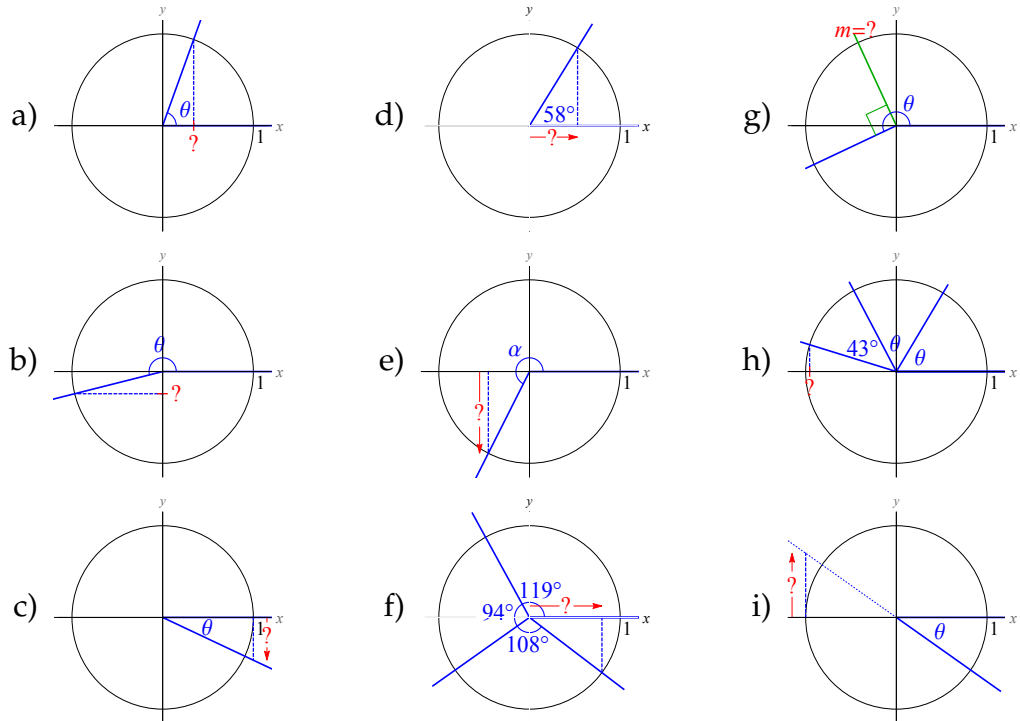

9. **NC** For each given quantity, determine which letter A-F best describes each quantity:

- | | |
|----------------------------|-----------------------------|
| A. between -1 and $-1/2$ | D. between 0 and $1/2$ |
| B. between $-1/2$ and 0 | E. between $1/2$ and 1 |
| C. exactly zero | F. not between -1 and 1 |

- | | | |
|---------------------|---------------------|---------------------|
| a) $\sin 110^\circ$ | d) $\cos 90^\circ$ | g) $\sin 0^\circ$ |
| b) $\cos -5^\circ$ | e) $\sin 257^\circ$ | h) $\sin 700^\circ$ |
| c) $\tan 10^\circ$ | f) $\cos 77^\circ$ | i) $\tan 40^\circ$ |

10. **NC** For each given quantity, determine which letter A-F best describes each quantity:

A. a very negative number
 B. a slightly negative number
 C. exactly zero

D. a slightly positive number
 E. a very positive number
 F. the quantity doesn't exist

- a) $\tan 110^\circ$ c) $\tan 265^\circ$ e) $\tan 270^\circ$
 b) $\tan -5^\circ$ d) $\tan -80^\circ$ f) $\tan 180^\circ$

11. [NC] Suppose $\cos\theta = -\frac{3}{4}$. What is $\cos(\theta + 360^\circ)$?
 12. [NC] Suppose $\sin\theta = .525$. What is $\sin(\theta + 8\pi)$?
 13. [NC] $\tan 76^\circ$ is very close to 4. Assuming this, give three other angles θ for which $\tan\theta$ is very close to 4.
 14. [NC] $\cos 113.6^\circ$ is very close to $-\frac{2}{5}$. Assuming this, give three other angles θ , at least one of which is negative, so that $\cos\theta$ is very close to $-\frac{2}{5}$.

Answers

1. a) $\sin \frac{\pi}{2} = \boxed{1}$ h) $\cos 900^\circ = \boxed{-1}$ o) $\tan -270^\circ = \boxed{\text{DNE}}$
 b) $\sin 90^\circ = \boxed{1}$ i) $\sin \frac{-13\pi}{2} = \boxed{-1}$ p) $\cos \frac{3\pi}{2} = \boxed{0}$
 c) $\cos \frac{-9\pi}{2} = \boxed{0}$ j) $\cos 270^\circ = \boxed{0}$ q) $\cos -180^\circ = \boxed{-1}$
 d) $\cos 2\pi = \boxed{1}$ k) $\tan 0 = \boxed{0}$ r) $\sin 450^\circ = \boxed{1}$
 e) $\cos 720^\circ = \boxed{1}$ l) $\cos -9\pi = \boxed{-1}$ s) $\tan \frac{-9\pi}{2} = \boxed{\text{DNE}}$
 f) $\tan 90^\circ = \boxed{\text{DNE}}$ m) $\tan \pi = \boxed{0}$ t) $\cos 630^\circ = \boxed{0}$
 g) $\tan -5\pi = \boxed{0}$ n) $\sin -12\pi = \boxed{0}$
2. a) $3 - 2\sin \frac{5\pi}{2} = \boxed{1}$ f) $\sin 7\pi + \pi = \boxed{\pi}$
 b) $\cos 180^\circ - 4\sin 0 = \boxed{-1}$ g) $\sin 180^\circ - 4\cos 90^\circ = \boxed{0}$
 c) $\tan \left(\pi + \frac{\pi}{2}\right) = \boxed{\text{DNE}}$ h) $\cos \left(\frac{5\pi}{4} + \frac{5\pi}{4}\right) = \boxed{0}$
 d) $\sin -2\pi + \tan \frac{-\pi}{2} = \boxed{\text{DNE}}$ i) $1 + 3\tan^2 1440^\circ = \boxed{1}$
 e) $3\sin^2 270^\circ = \boxed{3}$ j) $\cos 360^\circ \tan 180^\circ = \boxed{0}$

8.3. Chapter 3 Homework

3. a) $\cos 3\pi = \boxed{-1}$ f) $\tan \frac{\pi}{2} = \boxed{\text{DNE}}$ l) $\cos -270^\circ = \boxed{0}$
 b) $\tan 0^\circ = \boxed{0}$ g) $\sin -90^\circ = \boxed{-1}$ m) $\sin \frac{-19\pi}{2} = \boxed{1}$
 c) $\sin \frac{9\pi}{2} = \boxed{1}$ h) $\tan \frac{3\pi}{2} = \boxed{\text{DNE}}$ n) $\cos -450^\circ = \boxed{0}$
 d) $\cos \frac{7\pi}{2} = \boxed{0}$ i) $\cos 450^\circ = \boxed{0}$ o) $\cos \frac{15\pi}{2} = \boxed{0}$
 e) $\cos 4\pi = \boxed{1}$ j) $\tan 540^\circ = \boxed{0}$ p) $\sin 5\pi = \boxed{0}$
 k) $\sin \frac{-\pi}{2} = \boxed{-1}$

4. a) $\tan 10\pi \sin 630^\circ = \boxed{0}$ e) $-\cos \pi - \sin^5 \frac{11\pi}{2} = \boxed{2}$
 b) $3 \sin^2 \frac{\pi}{2} - 5 = \boxed{-2}$ f) $7 \tan -90^\circ = \boxed{\text{DNE}}$
 c) $\cos 0 - \tan \frac{-7\pi}{2} = \boxed{\text{DNE}}$ g) $\cos \frac{-14\pi}{2} \sin \frac{8\pi}{2} = \boxed{0}$
 d) $\cos -5 \cdot \frac{\pi}{2} = \boxed{0}$ h) $\tan \left(\frac{3\pi}{2} - \frac{\pi}{2} \right) - \pi = \boxed{-\pi}$

5. These are just estimates, so answers can vary a little bit here:

- a) $\sin \beta \approx -.9$; $\cos \beta \approx -.42$; $\tan \beta \approx 2$
 b) $\sin \theta \approx .9$; $\cos \theta \approx .4$; $\tan \theta \approx 2$
 c) $\sin \psi \approx -.3$; $\cos \psi \approx .95$; $\tan \psi \approx -\frac{1}{3}$

6. These are just estimates, so answers can vary a little bit here:

a) $\sin 160^\circ \approx \boxed{.35}$

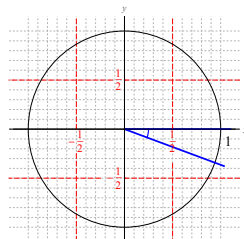
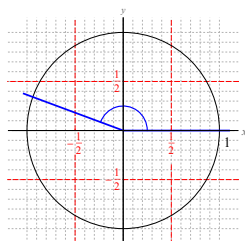

b) $\tan -140^\circ \approx \boxed{\frac{3}{4}}$

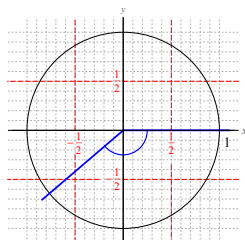

d) $\sin 70^\circ \approx \boxed{.92}$

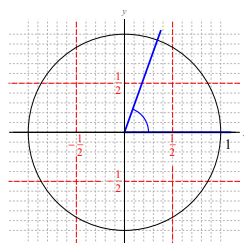

c) $\cos -20^\circ \approx \boxed{.9}$

e) $\tan -45^\circ \approx \boxed{-1}$

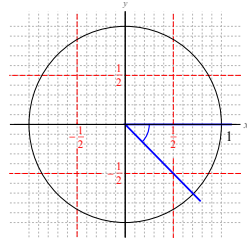

f) $\cos 760^\circ \approx \boxed{.75}$

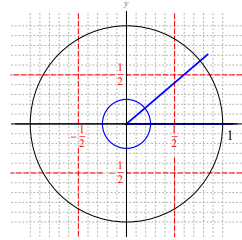

7. These are just estimates, so answers can vary somewhat.

- | | |
|---|--|
| a) $\theta \approx 190^\circ, \theta \approx 350^\circ$ | g) $\theta \approx 15^\circ, \theta \approx 345^\circ$ |
| b) $\theta \approx 95^\circ, \theta \approx 275^\circ$ | h) $\theta \approx 89^\circ, \theta \approx 269^\circ$ |
| c) $\theta = 90^\circ, \theta = 270^\circ$ | i) $\theta \approx 50^\circ, \theta \approx 310^\circ$ |
| d) $\theta \approx 260^\circ, \theta \approx 280^\circ$ | j) no solution |
| e) no solution | k) $\theta \approx 30^\circ, \theta \approx 330^\circ$ |
| f) $\theta \approx 85^\circ, \theta \approx 95^\circ$ | l) $\theta \approx 20^\circ, \theta \approx 160^\circ$ |

- | | | |
|---------------------|---------------------|-------------------------------|
| 8. a) $\cos \theta$ | d) $\cos 58^\circ$ | g) $\tan(\theta - 90^\circ)$ |
| b) $\sin \theta$ | e) $\sin \alpha$ | h) $\cos(2\theta + 43^\circ)$ |
| c) $\tan \theta$ | f) $\cos 321^\circ$ | i) $-\tan \theta$ |

- | | | | | |
|---------|------|------|------|------|
| 9. a) E | c) D | e) A | g) C | i) E |
| b) E | d) C | f) D | h) B | |

- | | | | | | |
|----------|------|------|------|------|------|
| 10. a) A | b) B | c) E | d) A | e) F | f) C |
|----------|------|------|------|------|------|

11. $\cos(\theta + 360^\circ) = \boxed{-\frac{3}{4}}$

12. $\sin(\theta + 8\pi) = \boxed{.525}$

13. $\boxed{\theta = 436^\circ, \theta = 796^\circ, \theta = 1156^\circ}$ (other answers are possible by adding or subtracting 360° to these).

14. $\boxed{\theta = 473.6^\circ, \theta = 833.6^\circ, \theta = -246.4^\circ}$ (other answers are possible by adding or subtracting 180° to these).

§3.2: Angle definitions

1. **NC** In each part of this problem, you are given a point on the terminal side of some angle, when that angle is drawn in standard position. Compute the sine and cosine and tangent of that angle.

- | | | | |
|------------|-----------|-------------|------------|
| a) (3, -5) | b) (2, 3) | c) (-4, -1) | d) (-5, 4) |
|------------|-----------|-------------|------------|

2. **NC** In each problem, determine whether the quantity is positive or negative:

- a) $\sin 675^\circ$ d) $\tan -125^\circ$ g) $\cos 305^\circ$
 b) $\cos 100^\circ$ e) $\tan 241^\circ$ h) $\cos 434^\circ$
 c) $\sin 115^\circ$ f) $\sin -205^\circ$ i) $\sin 282^\circ$

3. **NC** Determine whether each quantity is positive, negative or zero:

- a) $-2 \sin 119^\circ$ e) $3 \cos 100^\circ \sin 150^\circ$
 b) $\sin^2 18691845^\circ$ f) $\sin 130^\circ \cos 90^\circ$
 c) $4 \cos 206^\circ \sin 206^\circ$ g) $\frac{1}{4} \tan 2 \cdot 59^\circ \cos 316^\circ$
 d) $-\frac{2}{3} \tan^3 40^\circ \tan 281.5^\circ$ h) $-\sin(-16^\circ) \cos^2(-16^\circ)$

4. **OPT NC** Determine whether each quantity is positive, negative or zero:

- a) $\cos 1572^\circ$ e) $\cos^3 214.5^\circ$
 b) $8 \sin 208^\circ \tan 25^\circ$ f) $2 \tan^2 1000^\circ \cos 93^\circ$
 c) $-\tan 207.2^\circ \cos 144^\circ$ g) $4 \sin 2 \cdot 73^\circ$
 d) $\sin 356.5^\circ \cos 125.8^\circ$ h) $-3 \sin^3 78^\circ \tan^2(-5^\circ)$

5. **NC** In each part of this problem, you are given a picture with a quantity marked with a "?". Write a formula for the "?" in terms of the other quantities given in the picture.

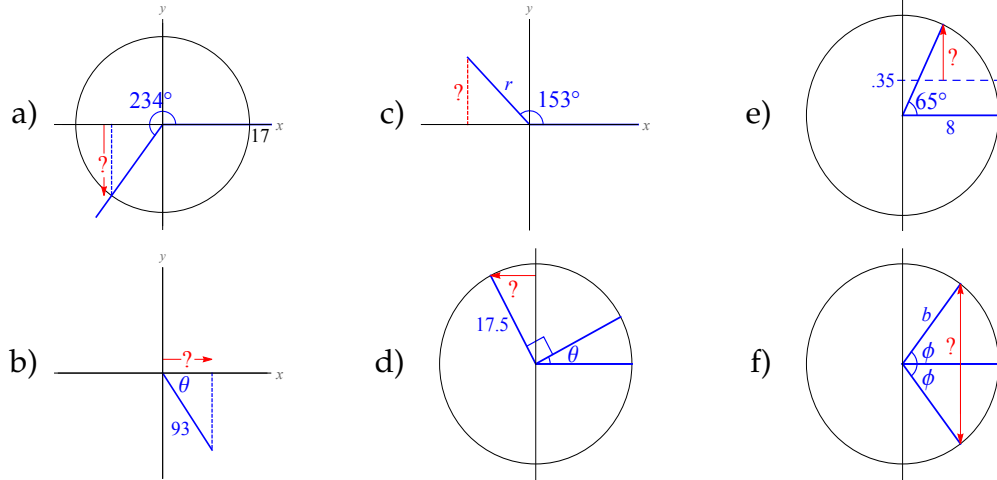

Answers

1. a) $\cos \theta = \frac{3}{\sqrt{34}}; \sin \theta = \frac{-5}{\sqrt{34}}; \tan \theta = -\frac{5}{3}$

- b) $\cos \theta = \frac{2}{\sqrt{13}}$; $\sin \theta = \frac{3}{\sqrt{13}}$; $\tan \theta = \frac{3}{2}$
- c) $\cos \theta = \frac{-4}{\sqrt{17}}$; $\sin \theta = \frac{-1}{\sqrt{17}}$; $\tan \theta = \frac{1}{4}$
- d) $\cos \theta = \frac{-5}{\sqrt{41}}$; $\sin \theta = \frac{4}{\sqrt{41}}$; $\tan \theta = -\frac{4}{5}$
2. a) negative d) positive g) positive
 b) negative e) positive h) positive
 c) positive f) positive i) negative
3. a) negative d) positive g) negative
 b) positive e) negative
 c) positive f) zero h) positive
4. a) negative d) positive g) positive
 b) negative e) negative
 c) positive f) negative h) negative
5. a) $17 \sin 234^\circ$ c) $r \sin 153^\circ$ e) $8 \sin 65^\circ - .35$
 b) $93 \cos \theta$ d) $17.5 \cos(\theta + 90^\circ)$ f) $2b \sin \phi$

§3.3: Computing sines and cosines with a calculator

1. Compute each quantity using a calculator:
- a) $\cos 52^\circ$ g) $\sin \frac{1}{2}$
 b) $\sin 43.2^\circ$ h) $2 \tan 53^\circ - \tan 241^\circ$
 c) $\tan 206.75^\circ$ i) $\cos 1 + \sin 53^\circ$
 d) $\sin 17^\circ + \cos 2^\circ$ j) $\frac{2}{5} \tan^3 64.6^\circ$
 e) $3 \tan 80^\circ \cos 92.5^\circ$ k) $\cos(22.7^\circ + 37.4^\circ)$
 f) $\sin \left(\frac{1}{2}\right)^\circ$
2. A pulley wheel of diameter 6 in is rotated 15° counterclockwise. How far to the left has a point at the top of the wheel rotated?
3. A chalk mark is made on the right edge of a tire of radius 33 inches. The tire is then rotated 3.385 revolutions counterclockwise. How far left or right from the center of the tire is the chalk mark?
4. The water wheel of an old mill has a radius of 27 feet (from the center of the wheel out to its buckets). If the wheel is rotated clockwise through an angle of 117.5° , how high above the bottom of the wheel will a bucket be, if the bucket started at the bottom of the wheel?

5. A centrifuge spins at 5000 rpm. If a test tube is put in the top of the centrifuge 3 cm from the center of the centrifuge, and the centrifuge is allowed to spin (counterclockwise) for $\frac{38}{7}$ seconds, how far above or below the center of the centrifuge is the test tube?
6. In each part of this problem, you are given the magnitude and direction angle of a vector. Sketch that vector in standard position.
- a) $|\mathbf{v}| = 15; \theta_{\mathbf{v}} = 73^\circ$ b) $|\mathbf{w}| = 143.65; \theta_{\mathbf{w}} = 194.5^\circ$
7. A vector has magnitude 60 and direction angle 143.75° . Compute the components of the vector, and then draw the vector in standard position.
8. If $|\mathbf{v}| = 44.35$ and \mathbf{v} has direction angle 81.25° , find the components of \mathbf{v} .
9. Determine the vertical component of a vector that has magnitude 17 and direction angle 215° .
10. Determine the components of the vector pictured below:

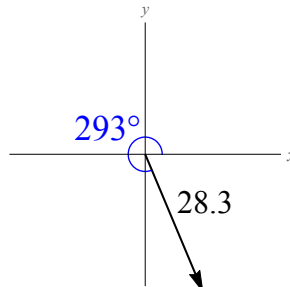

11. NC A vector has direction angle 30° and magnitude 20. Find the components of the vector.
12. NC Vector \mathbf{a} has magnitude $|\mathbf{a}| = 14$ and direction angle $\theta = 45^\circ$. Find the components of \mathbf{a} .
13. NC Compute the components of a vector whose direction angle is 180° and whose magnitude is 9.
14. NC Suppose that vector \mathbf{v} has direction angle 270° and magnitude 6. Find the components of \mathbf{v} .
15. A ship leaves a port, traveling on a bearing of 28° east of north. The ship travels for 82 miles, then turns due east and travels 43 miles. How far away from the port is the ship?

16. A BMX bike rider drives 3 miles on a bearing 10° south of west, then turns and rides 2 miles on a bearing 5° east of north, then turns again and rides 1 mile on a bearing 45° west of north. At this point, how far is the bike rider from where he started?
17. A jetski is ridden 650 feet on a bearing 35° east of north, and then ridden 425 feet on a bearing 28° south of east. At this point, how far is the jetski from where it started?

Answers

1. a) .615661
 b) .684547
 c) .504041
 d) 1.29176
 e) $-.742134$
 f) .00872654
 g) .479426
 h) .850042
 i) 1.33894
 j) 3.73622
 k) .498488

b) $\mathbf{w} = \langle -139.074, -35.9671 \rangle$

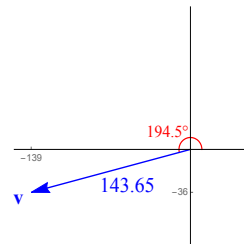

7. $\langle -48.3867, 35.4786 \rangle$

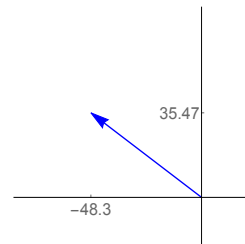

2. 0.776457 in
 3. 24.7537 inches left of the center.
 4. 39.4672 ft
 5. 2.70291 cm below the center.
 6. a) $\mathbf{v} = \langle 4.38558, 14.3446 \rangle$

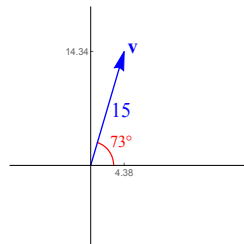

8. $\mathbf{v} = \langle 6.74667, 43.8338 \rangle$
 9. -9.7508
 10. $\langle 11.0577, -26.0503 \rangle$
 11. $\langle 10\sqrt{3}, 10 \rangle$
 12. $\mathbf{a} = \langle 7\sqrt{2}, 7\sqrt{2} \rangle$
 13. $\langle -9, 0 \rangle$
 14. $\mathbf{v} = \langle 0, -6 \rangle$
 15. 109.012 miles
 16. 4.11179 miles
 17. 818.815 ft

§3.4: Basic identities

- [NC] Suppose $\cos \theta = \frac{2}{3}$ and $\sin \theta > 0$. Compute each quantity:

a) $\cos(\theta + 360^\circ)$	d) $\sin \theta$	g) $3 \sin(\theta + 720^\circ)$
b) $-\cos \theta$	e) $2 \sin \theta + 3 \cos \theta$	h) $\tan \theta$
c) $\cos(\theta - 720^\circ)$	f) $\sin(\theta + 2\pi)$	i) $\tan(\theta - 4\pi)$
- Suppose $\sin \alpha = \frac{5}{13}$ and $\cos \alpha = -\frac{12}{13}$. Compute $\tan \alpha$.
- Suppose $\cos \gamma = \frac{-2}{\sqrt{85}}$ and $\tan \gamma = \frac{9}{2}$. Compute $\sin \gamma$.
- [NC] Suppose $\cos \theta = \frac{3}{7}$. Compute all possible values of $\sin \theta$.
- [NC] Suppose $\sin \beta = \frac{-1}{3}$. If $\cos \beta > 0$, compute the exact value of $\cos \beta$.
- Suppose θ is in Quadrant III and $\sin \theta = -.614$. Compute $\cos \theta$.
- Suppose $\cos \theta = .552$ and $\sin \theta < 0$. Compute $\sin \theta$ and $\tan \theta$.
- Suppose $\sin \theta = -\frac{108}{257}$ and $\cos \theta < 0$. Compute $\cos \theta$ and $\tan \theta$.

Answers

- | | |
|--|--|
| 1. a) $\cos(\theta + 360^\circ) = \frac{2}{3}$ | 3. $\sin \gamma = -\frac{9}{\sqrt{85}}$ |
| b) $-\cos \theta = -\frac{2}{3}$ | 4. $\sin \theta = \pm \frac{\sqrt{40}}{7}$ |
| c) $\cos(\theta - 720^\circ) = \frac{2}{3}$ | 5. $\cos \beta = \frac{\sqrt{8}}{3}$ |
| d) $\sin \theta = \frac{\sqrt{5}}{3}$ | 6. $\cos \theta = -.789306$ |
| e) $2 \sin \theta + 3 \cos \theta = \frac{2\sqrt{5}+6}{3}$ | 7. $\sin \theta = -.833844$;
$\tan \theta = -.6661994$ |
| f) $\sin(\theta + 2\pi) = \frac{\sqrt{5}}{3}$ | 8. $\cos \theta = -.907416$;
$\tan \theta = -.46311$ |
| g) $3 \sin(\theta + 720^\circ) = \sqrt{5}$ | |
| h) $\tan \theta = \frac{\sqrt{5}}{2}$ | |
| i) $\tan(\theta - 4\pi) = \frac{\sqrt{5}}{2}$ | |
- $\tan \alpha = -\frac{5}{12}$.

§3.5: Reflection properties

1. **NC** Suppose $\sin \theta = .44$. Compute each quantity:

a) $\sin(\theta - 360^\circ)$	c) $\cos(90^\circ - \theta)$	e) $\sin(360^\circ - \theta)$
b) $\sin(-\theta)$	d) $\sin(\theta + 1080^\circ)$	f) $-2 \sin(360^\circ + \theta)$

2. **NC** Suppose $\tan \alpha = 3$ and α is not in Quadrant I. Compute each quantity:

a) $\tan(\alpha + 180^\circ)$	e) $\tan(180^\circ - \alpha)$
b) $\tan(360^\circ - \alpha)$	f) $-\tan^2 \alpha$
c) $\tan(-\alpha)$	g) $2 \tan^3(180^\circ - \alpha) + 4$
d) $\tan(\alpha + 720^\circ)$	h) $\tan(900^\circ - \alpha)$

3. **NC** Suppose $\cos \theta = \frac{2}{5}$ and $\sin \theta < 0$. Compute each quantity:

a) $\cos(180^\circ - \theta)$	e) $4 \cos(\theta + 180^\circ)$
b) $\tan(\theta + 540^\circ)$	f) $\sin^2(90^\circ - \theta)$
c) $\sin(720^\circ - \theta)$	g) $2 \tan \theta \sin(360^\circ - \theta)$
d) $\tan(-\theta)$	h) $\cos^2 \theta \sin^2(180^\circ - \theta)$

4. **NC** Suppose θ is angle whose terminal side lies in Quadrant III when θ is drawn in standard position.

a) Is $\sin \theta$ positive or negative?	e) What quadrant is $-\theta$ in?
b) Is $\cos(-\theta)$ positive or negative?	f) What is the sign of $\cos(180^\circ - \theta)$?
c) Is $\tan \theta$ positive or negative?	g) What is the sign of $\tan(\theta + 180^\circ)$?
d) What quadrant is $\theta - 90^\circ$ in?	h) What is the sign of $\sin(360^\circ - \theta)$?

5. **OPT NC** Suppose θ is in Quadrant IV (meaning that the terminal side of θ lies in Quadrant IV when θ is drawn in standard position).

a) Is $\sin \theta$ positive or negative?	g) What quadrant is $180^\circ - \theta$ in?
b) Is $\cos \theta$ positive or negative?	h) What is the sign of $\sin(180^\circ - \theta)$?
c) Is $\cos(-\theta)$ positive or negative?	i) What is the sign of $\cos(360^\circ + \theta)$?
d) Is $\tan \theta$ positive or negative?	j) What is the sign of $\tan(180^\circ - \theta)$?
e) Is $\tan(-\theta)$ positive or negative?	k) What is the sign of $\tan(\theta + 540^\circ)$?
f) What quadrant is $\theta + 90^\circ$ in?	

6. **NC** Suppose $\left(\frac{24}{25}, \frac{7}{25}\right)$ is the point on the unit circle at angle θ . Compute each quantity:

- | | | |
|------------------|------------------------------|-------------------------------|
| a) $\sin \theta$ | d) $\cos(-\theta)$ | g) $\cos(180^\circ - \theta)$ |
| b) $\cos \theta$ | e) $3 \tan(-\theta)$ | h) $\sin(\theta + 720^\circ)$ |
| c) $\tan \theta$ | f) $\cos(90^\circ - \theta)$ | i) $\tan(90^\circ - \theta)$ |

7. **NC** Suppose (x, y) is the point on the unit circle at angle θ .

- What is $\sin \theta$?
- What is $\cos \theta$?
- What is $\cos(\theta - 180^\circ)$?
- What is $\tan(360^\circ - \theta)$?
- What is $\sin(90^\circ - \theta)$?
- What is $\tan(90^\circ - \theta)$?
- What is $\sin(180^\circ - \theta)$?
- What is $\cos(\theta + 720^\circ)$?
- What angle α has $\sin \alpha = -y$, $\cos \alpha = x$?
(Here, α is meant to be in terms of θ .)
- What angle β has $\sin \alpha = -y$, $\cos \beta = -x$?
(Here, α is meant to be in terms of θ .)
- What two angles γ have $\tan \gamma = -\frac{y}{x}$?
(Here, the angles γ are meant to be in terms of θ .)

8. Suppose $\sin \alpha = .8$ and $\cos \alpha > 0$. Compute each quantity:

- | | |
|------------------------------|--------------------------------|
| a) $\cos \alpha$ | e) $\sin(\alpha + 360^\circ)$ |
| b) $\cos(-\alpha)$ | f) $\cos(360^\circ - \alpha)$ |
| c) $\sin(-\alpha)$ | g) $\sin(\alpha - 1440^\circ)$ |
| d) $\cos(90^\circ - \alpha)$ | h) $\cos(450^\circ - \alpha)$ |

Answers

- | | |
|--|---|
| 1. a) $\sin(\theta - 360^\circ) = \boxed{.44}$ | d) $\sin(\theta + 1080^\circ) = \boxed{.44}$ |
| b) $\sin(-\theta) = \boxed{-.44}$ | e) $\sin(360^\circ - \theta) = \boxed{-.44}$ |
| c) $\cos(90^\circ - \theta) = \boxed{.44}$ | f) $-2 \sin(360^\circ + \theta) = \boxed{-.88}$ |

8.3. Chapter 3 Homework

2. a) $\tan(\alpha + 180^\circ) = \boxed{3}$
 b) $\tan(360^\circ - \alpha) = \boxed{-3}$
 c) $\tan(-\alpha) = \boxed{-3}$
 d) $\tan(\alpha + 720^\circ) = \boxed{3}$
3. a) $\cos(180^\circ - \theta) = \boxed{-\frac{2}{5}}$
 b) $\tan(\theta + 540^\circ) = \boxed{-\frac{\sqrt{21}}{2}}$
 c) $\sin(720^\circ - \theta) = \boxed{\frac{\sqrt{21}}{5}}$
 d) $\tan(-\theta) = \boxed{\frac{\sqrt{21}}{2}}$
4. a) negative c) positive
 b) negative d) III
5. a) negative d) negative
 b) positive e) positive
 c) positive f) I
6. a) $\sin \theta = \boxed{\frac{7}{25}}$
 b) $\cos \theta = \boxed{\frac{24}{25}}$
 c) $\tan \theta = \boxed{\frac{7}{24}}$
 d) $\cos(-\theta) = \boxed{\frac{24}{25}}$
 e) $3 \tan(-\theta) = \boxed{-\frac{7}{8}}$
7. a) $\sin \theta = \boxed{y}$
 b) $\cos \theta = \boxed{x}$
 c) $\cos(\theta - 180^\circ) = \boxed{-x}$
 d) $\tan(360^\circ - \theta) = \boxed{-\frac{y}{x}}$
 e) $\sin(90^\circ - \theta) = \boxed{x}$
 f) $\tan(90^\circ - \theta) = \boxed{\frac{x}{y}}$
- e) $\tan(180^\circ - \alpha) = \boxed{-3}$
 f) $-\tan^2 \alpha = -9$
 g) $2 \tan^3(180^\circ - \alpha) + 4 = \boxed{-50}$
 h) $\tan(900^\circ - \alpha) = \boxed{-3}$
- e) $4 \cos(\theta + 180^\circ) = \boxed{-\frac{8}{5}}$
 f) $\sin^2(90^\circ - \theta) = \boxed{\frac{4}{25}}$
 g) $2 \tan \theta \sin(360^\circ - \theta) = \boxed{\frac{21}{5}}$
 h) $\cos^2 \theta \sin^2(180^\circ - \theta) = \boxed{\frac{84}{625}}$
- e) II g) positive
 f) positive h) positive
- g) III j) positive
 h) negative
 i) positive k) negative
- f) $\cos(90^\circ - \theta) = \boxed{\frac{7}{25}}$
 g) $\cos(180^\circ - \theta) = \boxed{-\frac{24}{25}}$
 h) $\sin(\theta + 720^\circ) = \boxed{\frac{7}{25}}$
 i) $\tan(90^\circ - \theta) = \boxed{\frac{24}{7}}$
 g) $\sin(180^\circ - \theta) = \boxed{y}$
 h) $\cos(\theta + 720^\circ) = \boxed{x}$
 i) $\alpha = \boxed{-\theta}$
 (or $\alpha = \boxed{360^\circ - \theta}$)
 j) $\beta = \boxed{\theta + 180^\circ}$
 (or $\beta = \boxed{\theta - 180^\circ}$)
 k) $\gamma = \boxed{-\theta}$ and $\gamma = \boxed{180^\circ - \theta}$

8. a) $\cos \alpha = \boxed{.6}$ e) $\sin(\alpha + 360^\circ) = \boxed{.8}$
 b) $\cos(-\alpha) = \boxed{.6}$ f) $\cos(360^\circ - \alpha) = \boxed{.6}$
 c) $\sin(-\alpha) = \boxed{-.8}$ g) $\sin(\alpha - 1440^\circ) = \boxed{.8}$
 d) $\cos(90^\circ - \alpha) = \boxed{.8}$ h) $\cos(450^\circ - \alpha) = \boxed{.8}$

§3.6: Sines, cosines and tangents of special angles

1. **NC** Compute the exact value of each expression:

a) $\sin 45^\circ$	d) $\tan 30^\circ$	f) $\sin 60^\circ$	h) $\tan 90^\circ$
b) $\cos 0^\circ$			
c) $\tan \frac{\pi}{4}$	e) $\cos \frac{\pi}{2}$	g) $\cos \frac{\pi}{6}$	i) $\cos \frac{\pi}{3}$

2. **OPT NC** Compute the exact value of each expression:

a) $\tan 0$	d) $\sin \frac{\pi}{2}$	f) $\tan 60^\circ$	h) $\sin 30^\circ$
b) $\sin 90^\circ$			
c) $\cos 45^\circ$	e) $\sin \frac{\pi}{6}$	g) $\cos \frac{\pi}{4}$	i) $\sin \frac{\pi}{3}$

3. **NC** Evaluate each expression:

a) $\sin \frac{3\pi}{2}$	d) $\cos -5\pi$	g) $\cos \frac{\pi}{2}$	j) $\tan \frac{-\pi}{4}$
b) $\tan \frac{-3\pi}{4}$	e) $\sin \frac{-5\pi}{2}$	h) $\cos \pi$	k) $\tan \frac{-4\pi}{3}$
c) $\sin \frac{-\pi}{3}$	f) $\tan \frac{-5\pi}{6}$	i) $\cos \frac{2\pi}{3}$	l) $\sin \frac{11\pi}{3}$

4. **NC** Evaluate each expression:

a) $\sin 180^\circ$	d) $\tan 480^\circ$	g) $\sin 540^\circ$	j) $\tan 120^\circ$
b) $\sin 330^\circ$	e) $\sin 360^\circ$	h) $\sin 225^\circ$	k) $\cos 150^\circ$
c) $\cos 210^\circ$	f) $\tan 315^\circ$	i) $\cos -90^\circ$	l) $\cos 570^\circ$

5. **NC** Evaluate each expression:

a) $\cos \frac{19\pi}{6}$	d) $\cos -\pi$	g) $\tan \frac{-2\pi}{3}$	j) $\sin -6\pi$
b) $\cos \frac{-13\pi}{4}$	e) $\tan \frac{-\pi}{6}$	h) $\cos \frac{7\pi}{6}$	k) $\tan \frac{15\pi}{4}$
c) $\sin \frac{11\pi}{2}$	f) $\cos \frac{-\pi}{3}$	i) $\cos \frac{5\pi}{6}$	l) $\sin \frac{19\pi}{4}$

6. **NC** Evaluate each expression:

a) $\cos 5 \cdot 0$

b) $\sin^2 \frac{\pi}{3}$

c) $\tan \left(\frac{2\pi}{3} - \frac{\pi}{3} \right)$

d) $4 \cos^2 \frac{\pi}{4}$

e) $2 \sin \left(\pi + \frac{\pi}{2} \right)$

f) $3 \tan^2 \frac{5\pi}{3}$

g) $\cos(2\pi - \pi) \sin \left(\frac{\pi}{2} - \frac{\pi}{4} \right)$

h) $\frac{\sin 45^\circ}{\cos 45^\circ}$

i) $3 + 2 \tan \frac{-15\pi}{4}$

7. **NC** Evaluate each expression:

a) $\sin(17^\circ + 42^\circ - 29^\circ)$

b) $5 \cos^2 60^\circ$

c) $3 \tan^4 120^\circ$

d) $12 \sin 270^\circ - 8 \cos 180^\circ$

e) $\sin 270^\circ + 3$

f) $\sin 135^\circ \tan 240^\circ$

g) $\sin^2 9 \cdot 70^\circ$

h) $\sin(\cos 270^\circ)$

8. **NC** Evaluate each expression:

a) $3 \cos^2 \frac{3\pi}{4}$

b) $\tan \frac{2\pi}{3} + \tan \frac{4\pi}{3}$

c) $2 \sin \frac{5\pi}{2} \cos \frac{4\pi}{3}$

d) $-4 \sin^2 \frac{7\pi}{6}$

e) $\frac{1}{2} \tan \frac{5\pi}{4}$

f) $2 \cos 7\pi + 3 \sin \frac{3\pi}{2}$

g) $5 \cos 3 \cdot \frac{\pi}{6}$

h) $2 \tan \frac{5\pi}{6} \cos \frac{5\pi}{4}$

i) $-\cos(3\pi - 2\pi)$

9. **NC** Evaluate each expression:

a) $\sin \left(\frac{5\pi}{6} + \frac{5\pi}{6} \right)$

b) $\sin \frac{5\pi}{6} + \frac{5\pi}{6}$

c) $\tan \frac{7\pi}{2} + \cos \pi$

d) $3 \cos^3 \frac{13\pi}{3}$

e) $\tan \pi + \frac{\pi}{2}$

f) $2 \cos \frac{5\pi}{4} + 3 \sin \frac{-\pi}{4}$

g) $\cos \frac{\pi}{2} \sin \frac{\pi}{5}$

h) $\tan \left(\frac{\pi}{3} - \cos \frac{\pi}{2} \right)$

i) $-\sin -\frac{3\pi}{4}$

The rest of these problems are just more practice exercises covering special angles.

10. **OPT** **NC** Evaluate each expression:

a) $\cos \frac{\pi}{6}$

c) $\tan \frac{3\pi}{4}$

d) $\cos \frac{-5\pi}{3}$

e) $\sin \frac{2\pi}{3}$

b) $\cos 2\pi$

$$\begin{array}{llll} \text{f) } \tan \frac{-13\pi}{6} & \text{h) } \cos \frac{33\pi}{2} & \text{j) } \cos \frac{7\pi}{4} & \text{l) } \sin \frac{-\pi}{6} \\ \text{g) } \sin \frac{-7\pi}{4} & \text{i) } \cos \frac{\pi}{3} & \text{k) } \sin \frac{\pi}{2} & \end{array}$$

11. OPT NC Evaluate each expression:

$$\begin{array}{llll} \text{a) } \sin \frac{-\pi}{2} & \text{d) } \tan \frac{-\pi}{4} & \text{g) } \sin \frac{3\pi}{4} & \text{j) } \cos \frac{-5\pi}{4} \\ \text{b) } \sin \frac{-7\pi}{6} & \text{e) } \sin \frac{-\pi}{2} & \text{h) } \sin \frac{-7\pi}{3} & \text{k) } \sin \frac{13\pi}{2} \\ \text{c) } \cos \frac{8\pi}{3} & \text{f) } \tan -2\pi & \text{i) } \tan \frac{\pi}{6} & \text{l) } \cos 0 \end{array}$$

12. OPT NC Evaluate each expression:

$$\begin{array}{llll} \text{a) } \tan \frac{\pi}{3} & \text{d) } \sin \frac{29\pi}{6} & \text{g) } \sin \frac{11\pi}{6} & \text{j) } \sin \frac{-2\pi}{3} \\ \text{b) } \sin \frac{-3\pi}{2} & \text{e) } \sin -\pi & \text{h) } \tan \frac{5\pi}{2} & \text{k) } \tan \frac{\pi}{4} \\ \text{c) } \cos \frac{9\pi}{4} & \text{f) } \cos \frac{11\pi}{3} & \text{i) } \sin \frac{5\pi}{6} & \text{l) } \sin \frac{4\pi}{3} \end{array}$$

13. OPT NC Evaluate each expression:

$$\begin{array}{llll} \text{a) } \cos \frac{3\pi}{2} & \text{d) } \sin 4\pi & \text{g) } \cos \frac{23\pi}{2} & \text{j) } \sin \frac{27\pi}{2} \\ \text{b) } \sin \frac{5\pi}{4} & \text{e) } \cos \frac{-7\pi}{2} & \text{h) } \tan \pi & \text{k) } \sin \frac{17\pi}{6} \\ \text{c) } \cos \frac{17\pi}{3} & \text{f) } \tan \frac{-5\pi}{6} & \text{i) } \sin \frac{-11\pi}{6} & \text{l) } \cos \frac{-11\pi}{4} \end{array}$$

14. OPT NC Evaluate each expression:

$$\begin{array}{llll} \text{a) } \cos \frac{\pi}{4} & \text{d) } \cos \frac{21\pi}{4} & \text{g) } \cos \frac{5\pi}{2} & \text{j) } \cos \frac{11\pi}{2} \\ \text{b) } \tan \frac{-3\pi}{2} & \text{e) } \tan 0 & \text{h) } \tan \frac{7\pi}{6} & \text{k) } \sin 3\pi \\ \text{c) } \cos \frac{7\pi}{2} & \text{f) } \tan \frac{4\pi}{3} & \text{i) } \cos \frac{3\pi}{4} & \text{l) } \cos \frac{23\pi}{6} \end{array}$$

15. OPT NC Evaluate each expression:

$$\begin{array}{llll} \text{a) } \sin 480^\circ & \text{d) } \tan -450^\circ & \text{g) } \tan 930^\circ & \text{j) } \tan -240^\circ \\ \text{b) } \cos 60^\circ & \text{e) } \cos -120^\circ & \text{h) } \cos 225^\circ & \text{k) } \sin -135^\circ \\ \text{c) } \cos 270^\circ & \text{f) } \sin -180^\circ & \text{i) } \tan 270^\circ & \text{l) } \cos 135^\circ \end{array}$$

16. **OPT** **NC** Evaluate each expression:

- | | | | |
|----------------------|-----------------------|----------------------|----------------------|
| a) $\sin 150^\circ$ | d) $\cos -120^\circ$ | g) $\cos 300^\circ$ | j) $\sin 210^\circ$ |
| b) $\tan -225^\circ$ | e) $\tan -30^\circ$ | h) $\sin -225^\circ$ | k) $\cos 180^\circ$ |
| c) $\cos -30^\circ$ | f) $\sin -1440^\circ$ | i) $\cos -720^\circ$ | l) $\tan -150^\circ$ |

17. **OPT** **NC** Evaluate each expression:

- | | | | |
|----------------------|---------------------|----------------------|---------------------|
| a) $\sin 315^\circ$ | d) $\cos -45^\circ$ | g) $\tan 330^\circ$ | j) $\tan 240^\circ$ |
| b) $\cos 240^\circ$ | e) $\sin 135^\circ$ | h) $\sin 270^\circ$ | k) $\sin 45^\circ$ |
| c) $\cos 1080^\circ$ | f) $\cos 120^\circ$ | i) $\sin -300^\circ$ | l) $\cos 600^\circ$ |

Answers

- | | | |
|--|--|---|
| 1. a) $\sin 45^\circ = \frac{\sqrt{2}}{2}$ | f) $\tan 60^\circ = \sqrt{3}$ | k) $\tan \frac{-4\pi}{3} = -\sqrt{3}$ |
| b) $\cos 0^\circ = 1$ | g) $\cos \frac{\pi}{4} = \frac{\sqrt{2}}{2}$ | l) $\sin \frac{11\pi}{3} = -\frac{\sqrt{3}}{2}$ |
| c) $\tan \frac{\pi}{4} = 1$ | h) $\sin 30^\circ = \frac{1}{2}$ | 4. a) $\sin 180^\circ = 0$ |
| d) $\tan 30^\circ = \frac{1}{\sqrt{3}}$ | i) $\sin \frac{\pi}{3} = \frac{\sqrt{3}}{2}$ | b) $\sin 330^\circ = -\frac{1}{2}$ |
| e) $\cos \frac{\pi}{2} = 0$ | 3. a) $\sin \frac{3\pi}{2} = -1$ | c) $\cos 210^\circ = -\frac{\sqrt{3}}{2}$ |
| f) $\sin 60^\circ = \frac{\sqrt{3}}{2}$ | b) $\tan \frac{-3\pi}{4} = 1$ | d) $\tan 480^\circ = -\sqrt{3}$ |
| g) $\cos \frac{\pi}{6} = \frac{\sqrt{3}}{2}$ | c) $\sin \frac{-\pi}{3} = -\frac{\sqrt{3}}{2}$ | e) $\sin 360^\circ = 0$ |
| h) $\tan 90^\circ = \text{DNE}$ | d) $\cos -5\pi = -1$ | f) $\tan 315^\circ = -1$ |
| i) $\cos \frac{\pi}{3} = \frac{1}{2}$ | e) $\sin \frac{-5\pi}{2} = -1$ | g) $\sin 540^\circ = 0$ |
| 2. a) $\tan 0 = 0$ | f) $\tan \frac{-5\pi}{6} = \frac{1}{\sqrt{3}}$ | h) $\sin 225^\circ = -\frac{\sqrt{2}}{2}$ |
| b) $\sin 90^\circ = 1$ | g) $\cos \frac{\pi}{2} = 0$ | i) $\cos -90^\circ = 0$ |
| c) $\cos 45^\circ = \frac{\sqrt{2}}{2}$ | h) $\cos \pi = -1$ | j) $\tan 120^\circ = -\sqrt{3}$ |
| d) $\sin \frac{\pi}{2} = 1$ | i) $\cos \frac{2\pi}{3} = -\frac{1}{2}$ | k) $\cos 150^\circ = -\frac{\sqrt{3}}{2}$ |
| e) $\sin \frac{\pi}{6} = \frac{1}{2}$ | j) $\tan \frac{-\pi}{4} = -1$ | l) $\cos 570^\circ = -\frac{1}{2}$ |
| | | 5. a) $\cos \frac{19\pi}{6} = \frac{1}{2}$ |

8.3. Chapter 3 Homework

- b) $\cos \frac{-13\pi}{4} = \boxed{-\frac{\sqrt{2}}{2}}$ f) $\cos \frac{-\pi}{3} = \boxed{\frac{1}{2}}$ i) $\cos \frac{5\pi}{6} = \boxed{-\frac{\sqrt{3}}{2}}$
- c) $\sin \frac{11\pi}{2} = \boxed{1}$ g) $\tan \frac{-2\pi}{3} = \boxed{\sqrt{3}}$ j) $\sin -6\pi = \boxed{0}$
- d) $\cos -\pi = \boxed{-1}$ h) $\cos \frac{7\pi}{6} = \boxed{-\frac{\sqrt{3}}{2}}$ k) $\tan \frac{15\pi}{4} = \boxed{-1}$
- e) $\tan \frac{-\pi}{6} = \boxed{-\frac{1}{\sqrt{3}}}$ l) $\sin \frac{19\pi}{4} = \boxed{\frac{\sqrt{2}}{2}}$
6. a) $\cos 5 \cdot 0 = \cos 0 = \boxed{1}$
- b) $\sin^2 \frac{\pi}{3} = \left(\frac{\sqrt{3}}{2}\right)^2 = \boxed{\frac{3}{4}}$
- c) $\tan \left(\frac{2\pi}{3} - \frac{\pi}{3}\right) = \tan \frac{\pi}{3} = \boxed{\sqrt{3}}$
- d) $4 \cos^2 \frac{\pi}{4} = 4 \left(\frac{\sqrt{2}}{2}\right)^2 = 4 \left(\frac{1}{2}\right) = \boxed{2}$
- e) $2 \sin \left(\pi + \frac{\pi}{2}\right) = 2 \sin \frac{3\pi}{2} = 2(-1) = \boxed{-2}$
- f) $3 \tan^2 \frac{5\pi}{3} = 3(\sqrt{3})^2 = \boxed{9}$
- g) $\cos(2\pi - \pi) \sin \left(\frac{\pi}{2} - \frac{\pi}{4}\right) = \cos \pi \sin \frac{\pi}{4} = (-1) \frac{\sqrt{2}}{2} = \boxed{-\frac{\sqrt{2}}{2}}$
- h) $\frac{\sin 45^\circ}{\cos 45^\circ} = \frac{\sqrt{2}/2}{\sqrt{2}/2} = \boxed{1}$
- i) $3 + 2 \tan \frac{-15\pi}{4} = 3 + 2(1) = \boxed{5}$
7. a) $\sin(17^\circ + 42^\circ - 29^\circ) = \sin 30^\circ = \boxed{\frac{1}{2}}$
- b) $5 \cos^2 60^\circ = 5 \left(\frac{1}{2}\right)^2 = \boxed{\frac{5}{4}}$
- c) $3 \tan^4 120^\circ = 3(\sqrt{3})^4 = \boxed{27}$
- d) $12 \sin 270^\circ - 8 \cos 180^\circ = 12(-1) - 8(-1) = \boxed{-4}$
- e) $\sin 270^\circ + 3 = -1 + 3 = \boxed{2}$
- f) $\sin 135^\circ \tan 240^\circ = \frac{\sqrt{2}}{2} \cdot -\sqrt{3} = \boxed{-\frac{\sqrt{6}}{2}}$
- g) $\sin^2 9 \cdot 70^\circ = \sin^2 630^\circ = (-1)^2 = \boxed{1}$
- h) $\sin(\cos 270^\circ) = \sin 0 = \boxed{0}$
8. a) $3 \cos^2 \frac{3\pi}{4} = 3 \left(-\frac{\sqrt{2}}{2}\right)^2 = \boxed{\frac{3}{2}}$

- b) $\tan \frac{2\pi}{3} + \tan \frac{4\pi}{3} = \sqrt{3} + \sqrt{3} = \boxed{2\sqrt{3}}$
- c) $2 \sin \frac{5\pi}{2} \cos \frac{4\pi}{3} = 2(1) \left(-\frac{1}{2}\right) = \boxed{-1}$
- d) $-4 \sin^2 \frac{7\pi}{6} = -4 \left(-\frac{1}{2}\right)^2 = \boxed{-1}$
- e) $\frac{1}{2} \tan \frac{5\pi}{4} = \frac{1}{2}(1) = \boxed{\frac{1}{2}}$
- f) $2 \cos 7\pi + 3 \sin \frac{3\pi}{2} = 2(-1) + 3(-1) = \boxed{-5}$
- g) $5 \cos 3 \cdot \frac{\pi}{6} = \boxed{0}$
- h) $2 \tan \frac{5\pi}{6} \cos \frac{5\pi}{4} = 2 \left(\frac{-1}{\sqrt{3}}\right) \frac{-\sqrt{2}}{2} = \boxed{\frac{\sqrt{2}}{\sqrt{3}}}$
- i) $-\cos(3\pi - 2\pi) = \boxed{1}$
9. a) $\sin \left(\frac{5\pi}{6} + \frac{5\pi}{6}\right) = \sin \frac{5\pi}{3} = \boxed{-\frac{\sqrt{3}}{2}}$
- b) $\sin \frac{5\pi}{6} + \frac{5\pi}{6} = \boxed{\frac{1}{2} + \frac{5\pi}{6}}$
- c) $\tan \frac{7\pi}{2} + \cos \pi = \text{DNE} - 1 = \boxed{\text{DNE}}$
- d) $3 \cos^3 \frac{13\pi}{3} = 3 \left(-\frac{1}{2}\right)^3 = 3 \left(\frac{1}{8}\right) = \boxed{-\frac{3}{8}}$
- e) $\tan \pi + \frac{\pi}{2} = 0 + \frac{\pi}{2} = \boxed{\frac{\pi}{2}}$
- f) $2 \cos \frac{5\pi}{4} + 3 \sin \frac{-\pi}{4} = 2 \left(-\frac{\sqrt{2}}{2}\right) + 3 \left(-\frac{\sqrt{2}}{2}\right) = \boxed{-\frac{5\sqrt{2}}{2}}$
- g) $\cos \frac{\pi}{2} \sin \frac{\pi}{5} = 0 \sin \frac{\pi}{5} = \boxed{0}$
- h) $\tan \left(\frac{\pi}{3} - \cos \frac{\pi}{2}\right) = \tan \frac{\pi}{3} = \boxed{\sqrt{3}}$
- i) $-\sin -\frac{3\pi}{4} = \boxed{\frac{\sqrt{2}}{2}}$
10. a) $\cos \frac{\pi}{6} = \boxed{\frac{\sqrt{3}}{2}}$
- b) $\cos 2\pi = \boxed{1}$
- c) $\tan \frac{3\pi}{4} = \boxed{-1}$
- d) $\cos \frac{-5\pi}{3} = \boxed{\frac{1}{2}}$
- e) $\sin \frac{2\pi}{3} = \boxed{\frac{\sqrt{3}}{2}}$
- f) $\tan \frac{-13\pi}{6} = \boxed{-\frac{1}{\sqrt{3}}}$
- g) $\sin \frac{-7\pi}{4} = \boxed{\frac{\sqrt{2}}{2}}$
- h) $\cos \frac{33\pi}{2} = \boxed{0}$
- i) $\cos \frac{\pi}{3} = \boxed{\frac{1}{2}}$
- j) $\cos \frac{7\pi}{4} = \boxed{\frac{\sqrt{2}}{2}}$
- k) $\sin \frac{\pi}{2} = \boxed{1}$
- l) $\sin \frac{-\pi}{6} = \boxed{-\frac{1}{2}}$

11. a) $\sin \frac{-\pi}{2} = \boxed{-1}$
 b) $\sin \frac{-7\pi}{6} = \boxed{\frac{1}{2}}$
 c) $\cos \frac{8\pi}{3} = \boxed{-\frac{1}{2}}$
 d) $\tan \frac{-\pi}{4} = \boxed{-1}$
 e) $\sin \frac{-\pi}{2} = \boxed{-1}$
 f) $\tan -2\pi = \boxed{0}$
 g) $\sin \frac{3\pi}{4} = \boxed{\frac{\sqrt{2}}{2}}$
 h) $\sin \frac{-7\pi}{3} = \boxed{-\frac{\sqrt{3}}{2}}$
 i) $\tan \frac{\pi}{6} = \boxed{\frac{1}{\sqrt{3}}}$
 j) $\cos \frac{-5\pi}{4} = \boxed{-\frac{\sqrt{2}}{2}}$
 k) $\sin \frac{13\pi}{2} = \boxed{1}$
 l) $\cos 0 = \boxed{1}$
12. a) $\tan \frac{\pi}{3} = \boxed{\sqrt{3}}$
 b) $\sin \frac{-3\pi}{2} = \boxed{1}$
 c) $\cos \frac{9\pi}{4} = \boxed{\frac{\sqrt{2}}{2}}$
 d) $\sin \frac{29\pi}{6} = \boxed{\frac{1}{2}}$
 e) $\sin -\pi = \boxed{0}$
 f) $\cos \frac{11\pi}{3} = \boxed{\frac{1}{2}}$
 g) $\sin \frac{11\pi}{6} = \boxed{-\frac{1}{2}}$
 h) $\tan \frac{5\pi}{2} = \boxed{\text{DNE}}$
 i) $\sin \frac{5\pi}{6} = \boxed{\frac{1}{2}}$
 j) $\sin \frac{-2\pi}{3} = \boxed{-\frac{\sqrt{3}}{2}}$
13. a) $\tan \frac{\pi}{4} = \boxed{1}$
 l) $\sin \frac{4\pi}{3} = \boxed{-\frac{\sqrt{3}}{2}}$
 a) $\cos \frac{3\pi}{2} = \boxed{0}$
 b) $\sin \frac{5\pi}{4} = \boxed{-\frac{\sqrt{2}}{2}}$
 c) $\cos \frac{17\pi}{3} = \boxed{\frac{1}{2}}$
 d) $\sin 4\pi = \boxed{0}$
 e) $\cos \frac{-7\pi}{2} = \boxed{0}$
 f) $\tan \frac{-5\pi}{6} = \boxed{\frac{1}{\sqrt{3}}}$
 g) $\cos \frac{23\pi}{2} = \boxed{0}$
 h) $\tan \pi = \boxed{0}$
 i) $\sin \frac{-11\pi}{6} = \boxed{\frac{1}{2}}$
 j) $\sin \frac{27\pi}{2} = \boxed{-1}$
 k) $\sin \frac{17\pi}{6} = \boxed{\frac{1}{2}}$
 l) $\cos \frac{-11\pi}{4} = \boxed{-\frac{\sqrt{2}}{2}}$
14. a) $\cos \frac{\pi}{4} = \boxed{\frac{\sqrt{2}}{2}}$
 b) $\tan \frac{-3\pi}{2} = \boxed{\text{DNE}}$
 c) $\cos \frac{7\pi}{2} = \boxed{0}$
 d) $\cos \frac{21\pi}{4} = \boxed{-\frac{\sqrt{2}}{2}}$
 e) $\tan 0 = \boxed{0}$
 f) $\tan \frac{4\pi}{3} = \boxed{\sqrt{3}}$
 g) $\cos \frac{5\pi}{2} = \boxed{0}$
 h) $\tan \frac{7\pi}{6} = \boxed{\frac{1}{\sqrt{3}}}$
- i) $\cos \frac{3\pi}{4} = \boxed{-\frac{\sqrt{2}}{2}}$
 j) $\cos \frac{11\pi}{2} = \boxed{0}$
 k) $\sin 3\pi = \boxed{0}$
 l) $\cos \frac{23\pi}{6} = \boxed{\frac{\sqrt{3}}{2}}$
15. a) $\sin 480^\circ = \boxed{\frac{\sqrt{3}}{2}}$
 b) $\cos 60^\circ = \boxed{\frac{1}{2}}$
 c) $\cos 270^\circ = \boxed{0}$
 d) $\tan -450^\circ = \boxed{\text{DNE}}$
 e) $\cos -120^\circ = \boxed{-\frac{1}{2}}$
 f) $\sin -180^\circ = \boxed{0}$
 g) $\tan 930^\circ = \boxed{\frac{1}{\sqrt{3}}}$
 h) $\cos 225^\circ = \boxed{-\frac{\sqrt{2}}{2}}$
 i) $\tan 270^\circ = \boxed{\text{DNE}}$
 j) $\tan -240^\circ = \boxed{-\sqrt{3}}$
 k) $\sin -135^\circ = \boxed{-\frac{\sqrt{2}}{2}}$
 l) $\cos 135^\circ = \boxed{-\frac{\sqrt{2}}{2}}$
16. a) $\sin 150^\circ = \boxed{\frac{1}{2}}$
 b) $\tan -225^\circ = \boxed{-1}$
 c) $\cos -30^\circ = \boxed{\frac{\sqrt{3}}{2}}$
 d) $\cos -120^\circ = \boxed{-\frac{1}{2}}$
 e) $\tan -30^\circ = \boxed{-\frac{1}{\sqrt{3}}}$
 f) $\sin -1440^\circ = \boxed{0}$

g) $\cos 300^\circ = \boxed{\frac{1}{2}}$	17. a) $\sin 315^\circ = \boxed{-\frac{\sqrt{2}}{2}}$	g) $\tan 330^\circ = \boxed{-\frac{1}{\sqrt{3}}}$
h) $\sin -225^\circ = \boxed{\frac{\sqrt{2}}{2}}$	b) $\cos 240^\circ = \boxed{-\frac{1}{2}}$	h) $\sin 270^\circ = \boxed{-1}$
i) $\cos -720^\circ = \boxed{1}$	c) $\cos 1080^\circ = \boxed{-1}$	i) $\sin -300^\circ = \boxed{\frac{\sqrt{3}}{2}}$
j) $\sin 210^\circ = \boxed{-\frac{1}{2}}$	d) $\cos -45^\circ = \boxed{\frac{\sqrt{2}}{2}}$	j) $\tan 240^\circ = \boxed{\sqrt{3}}$
k) $\cos 180^\circ = \boxed{-1}$	e) $\sin 135^\circ = \boxed{\frac{\sqrt{2}}{2}}$	k) $\sin 45^\circ = \boxed{\frac{\sqrt{2}}{2}}$
l) $\tan -150^\circ = \boxed{\frac{1}{\sqrt{3}}}$	f) $\cos 120^\circ = \boxed{-\frac{1}{2}}$	l) $\cos 600^\circ = \boxed{-\frac{1}{2}}$

§3.7: Arcsine, arccosine and arctangent

1. Compute each quantity with a calculator, giving your answer in degrees:

a) $\arcsin .275$	c) $\arctan .7825$	e) $\arctan -3.404$
b) $\arccos .481$	d) $\arcsin -\frac{8}{19}$	f) $\arctan 2.262$

2. **NC** Compute the exact value of each quantity by hand, giving your answer in radians:

a) $\arcsin \frac{1}{2}$	e) $\arcsin \frac{\sqrt{3}}{2}$	h) $\arcsin -\frac{1}{2}$
b) $\arccos 1$	f) $\arcsin 0$	i) $\arcsin -1$
c) $\arctan 1$	g) $\arccos -\frac{1}{2}$	j) $\arctan -\frac{1}{\sqrt{3}}$
d) $\arctan -\sqrt{3}$		

3. In each question, find all values of θ between 0° and 360° that satisfy the given equation. (If there are no such values, say so.)

a) $\sin \theta = \frac{11}{15}$	d) $\sin \theta = -.623$	g) $\sin \theta = \frac{17}{14}$
b) $\cos \theta = -1$	e) $\tan \theta = -\frac{2}{3}$	h) $\tan \theta = -5.3$
c) $\tan \theta = 2.164$	f) $\cos \theta = \frac{4}{13}$	i) $\cos \theta = 0$

4. Compute the direction angle of the vector $\mathbf{v} = \langle -18, 14 \rangle$. Then, draw a picture to illustrate what you have just computed.

5. Compute the direction angle of the vector $\mathbf{u} = \langle 9, 2 \rangle$. Then, draw a picture to illustrate what you have just computed.
6. Compute the magnitude and direction angle of the vector $\mathbf{v} = \langle 6.35, -2.84 \rangle$.
7. **NC** If \mathbf{v} has direction angle 40° , what is the direction angle of $3\mathbf{v}$? What about the direction angle of $-2\mathbf{v}$?
8. Three people push on a large crate. One pushes with a force of 300 Newtons due east; one pushes with a force of 220 Newtons at an angle 33° north of east, and one pushes with a force of 405 Newtons at an angle 71° south of east. In what direction (measured north or south of east) does the crate move?
9. Recall in Exercise 15 from the homework from §3.3 that there was a ship that left a port, traveling on a bearing of 28° east of north. The ship traveled for 82 miles, then turned due east and traveled 43 miles. At what bearing (measured south of west) would the ship have to travel to return to the port?
10. Recall the setup of Exercise 16 from the homework of §3.3, where a BMX bike rider drives 3 miles on a bearing 10° south of west, then turns and rides 2 miles on a bearing 5° east of north, then turns again and rides 1 mile on a bearing 45° west of north. If a second BMX rider, who is still at the location where the first one started, wanted to ride toward the first rider, at what angle would he have to ride?

Answers

1.
 - a) $\arcsin .275 = 15.96^\circ$
 - b) $\arccos .481 = 61.25^\circ$
 - c) $\arctan .7825 = 38.04^\circ$
 - d) $\arcsin -\frac{8}{19} = -24.9^\circ$
 - e) $\arctan -3.404 = -73.63^\circ$
 - f) $\arctan 2.262 = 66.15^\circ$
2.
 - a) $\arcsin \frac{1}{2} = \frac{\pi}{6}$
 - b) $\arccos 1 = 0$
 - c) $\arctan 1 = \frac{\pi}{4}$
 - d) $\arctan -\sqrt{3} = -\frac{\pi}{3}$
 - e) $\arcsin \frac{\sqrt{3}}{2} = \frac{\pi}{3}$
 - f) $\arcsin 0 = 0$
 - g) $\arccos -\frac{1}{2} = \frac{2\pi}{3}$
 - h) $\arcsin -\frac{1}{2} = -\frac{\pi}{6}$
 - i) $\arcsin -1 = -\frac{\pi}{2}$
 - j) $\arctan -\frac{1}{\sqrt{3}} = -\frac{\pi}{6}$
3.
 - a) $\theta = 47.17^\circ; \theta = 132.833^\circ$
 - b) $\theta = 180^\circ$
 - c) $\theta = 65.2^\circ; \theta = 245.2^\circ$
 - d) $\theta = 218.54^\circ; \theta = 321.46^\circ$

8.3. Chapter 3 Homework

- e) $\theta = 146.31^\circ; \theta = 326.31^\circ$
- f) $\theta = 72.08^\circ; \theta = 287.92^\circ$
- g) no solution
- h) $\theta = 100.685^\circ; \theta = 280.685^\circ$
- i) $\theta = 90^\circ; \theta = 270^\circ$

4. $\theta_{\mathbf{v}} = 142.125^\circ;$

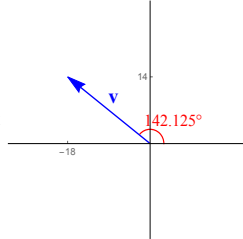

5. $\theta_{\mathbf{u}} = 12.53^\circ;$

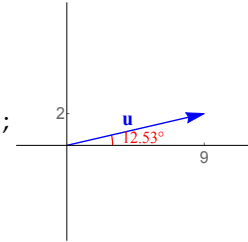

- 6. $|\mathbf{v}| = 6.956; \theta_{\mathbf{v}} = -24.1^\circ$
- 7. $\theta_{3\mathbf{v}} = 40^\circ; \theta_{-2\mathbf{v}} = 220^\circ.$
- 8. 43.8° south of east
- 9. 41.62° south of west
- 10. 32° north of east

8.4 Chapter 4 Homework

§4.1: Law of Sines

Remember that to “solve” a triangle means to find all missing side lengths and angle measures. You are responsible for identifying when no such triangle is possible, and for solving both triangles in the ambiguous case.

1. If $P = 42.5^\circ$, $Q = 71.4^\circ$ and $p = 215$, solve $\triangle PQR$.
2. If $B = 57^\circ$, $C = 31^\circ$ and $a = 7.3$, solve $\triangle ABC$.
3. If $J = 46^\circ$, $K = 95^\circ$ and $l = 6.8$, solve $\triangle JKL$.
4. If $B = 13.4^\circ$, $C = 24.8^\circ$ and $a = 315$, solve $\triangle ABC$.
5. If $A = 105^\circ$, $B = 45^\circ$ and $c = 630$, solve $\triangle ABC$.
6. If $A = 71^\circ$ and $c = 46$, solve right $\triangle ABC$.
7. If $A = 27.8^\circ$ and $b = 13.5$, solve right $\triangle ABC$.
8. If $R = 29.7^\circ$, $s = 41.5$ and $r = 27.2$, solve $\triangle RST$.
9. If $B = 74.3^\circ$, $a = 859$ and $b = 783$, solve $\triangle ABC$.
10. If $Q = 39.68^\circ$, $p = 29.81$ and $q = 23.76$, solve $\triangle PQR$.
11. If $A = 96.8^\circ$, $b = 3.589$ and $a = 5.818$, solve $\triangle ABC$.
12. If $C = 68.5^\circ$, $c = 258$ and $b = 386$, solve $\triangle ABC$.
13. The angle of elevation of the sun is 75° when a building casts a shadow of 45 feet. How tall is the building?
14. A surveyor determines the height of a pole by starting at the base of the pole and walking 50 feet along flat ground. She turns around and observes that the angle of elevation from her eyes to the top of the pole is 52.6° . If her eyes are 5 feet above the ground, how tall is the pole?
15. A man is flying in a hot-air balloon in a straight line, parallel to the ground, at a constant rate of 5 feet per second. While flying towards a tree, he notices the angle of depression from his position to the base of the tree is 35° , and then one second later, he notices the angle of depression to the same spot is 36° . What is the distance between the man in the balloon and the base of the tree (at the instant the angle of depression is 36°)?

16. A woman wants to measure the height of an antenna in the distance. She observes that the angle of elevation from the ground to the top of the antenna is 46° . She then walks 100 feet toward the antenna, and at that point observes that the angle of elevation from the ground to the top of the antenna is now 64° . What is the height of the antenna?

Answers

- | | | | |
|---|--|--|--|
| 1. $R = 66.1^\circ$;
$q = 302$;
$r = 291$. | 3. $L = 39^\circ$;
$j = 7.8$;
$k = 11$. | 5. $C = 30^\circ$;
$a = 1200$;
$b = 890$. | $b = 14.98$. |
| 2. $A = 92^\circ$;
$b = 6.1$;
$c = 3.8$. | 4. $A = 141.8^\circ$;
$b = 118$;
$c = 214$. | 6. $\angle C = 90^\circ$;
$\angle B = 19^\circ$;
$a = 43.49$; | 7. $\angle C = 90^\circ$;
$\angle B = 62.2^\circ$;
$a = 7.12$;
$c = 15.26$. |
| 8. There are two triangles. In the first triangle, $S = 49.1^\circ$, $T = 101.2^\circ$, and $t = 53.853$. In the second triangle, $S' = 130.9^\circ$, $T' = 19.4^\circ$ and $t' = 18.235$. | | | |
| 9. No such triangle exists. | | | |
| 10. There are two triangles. In the first triangle, $P = 53.23^\circ$, $R = 87.09^\circ$ and $r = 37.16$. In the second triangle, $P' = 126.77^\circ$, $R' = 13.55^\circ$ and $r' = 8.719$. | | | |
| 11. $B = 37.77^\circ$, $C = 45.43^\circ$, $c = 4.174$. | 14. 70.4 ft | | |
| 12. No such triangle exists. | 15. 273 ft | | |
| 13. 167.94 ft | 16. 209 ft | | |

§4.2: Law of Cosines

- If $a = 42.9$, $b = 37.6$ and $c = 62.7$, solve $\triangle ABC$.
- If $Q = 74.8^\circ$, $p = 8.92$ and $r = 6.43$, solve $\triangle PQR$.
- If $J = 41.4^\circ$, $k = 2.78$ and $l = 3.92$, solve $\triangle JKL$.
- If $a = 17$, $b = 38$ and $c = 15$, solve $\triangle ABC$.
- If $b = 22$ and $a = 7$, solve right $\triangle ABC$.
- Two ships leave a harbor together, travelling on courses that have an angle of 135.6° between them. If the first ship travels 300 mi and the second ship travels 350 mi, what is the distance between them?

Answers

- | | | |
|---------------------|-----------------------------|----------------------------|
| 1. $A = 42^\circ$; | $R = 40.6^\circ$. | 5. $c = 23.09$; |
| $B = 35.9^\circ$; | 3. $j = 2.6$; | $\angle A = 17.65^\circ$; |
| $C = 102.1^\circ$. | $K = 45.1^\circ$; | $\angle B = 72.35^\circ$; |
| 2. $q = 9.53$; | $L = 93.5^\circ$. | $\angle C = 90^\circ$. |
| $P = 64.6^\circ$; | 4. No such triangle exists. | 6. 602.112 mi |

§4.3: SOHCAHTOA

1. Compute the sine and cosine of angle θ , as given in the picture below.

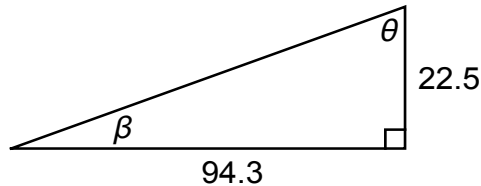

2. Compute the sine and cosine of angle β , as given in the picture above.
3. NC Suppose $\triangle PQR$ is a right triangle (with right angle at R) with side lengths $p = 10$ and $r = 26$. Compute the sine and cosine of angle P .

In each of Exercises 4-9, assume $\triangle ABC$ is a right triangle with the right angle at C .

4. If $A = 40^\circ$ and $c = 135$, find b .
5. If $A = 18.5^\circ$ and $b = 12.3$, find c .
6. If $A = 83^\circ$ and $a = 20$, find c .
7. If $B = 35.8^\circ$ and $c = 4$ ft, find b .
8. If $a = 19$ and $c = 135$, find A .
9. If $a = 19$ and $b = 13$ in, find B .
10. An escalator will carry people a vertical distance of 15 feet between floors. If the escalator makes an angle of 37.5° with the floor, how long should the escalator be?
11. A 80 foot rope from the top of a pole is anchored to the ground, 45 feet from the bottom of the pole. What angle does the rope make with the ground?
12. A person standing 2 m from a mirror observes that the angle of depression from his eyes to the bottom of the mirror is 15° , whereas the angle of elevation from his eyes to the top of the mirror is 5° . What is the height of the mirror?

Answers

- | | | | |
|----------------------------|------------------------------|----------------------------|-----------------------------|
| 1. $\sin \theta = .9727$; | 3. $\sin P = \frac{5}{13}$; | 5. $c = 12.97$ | 9. $\angle B = 34.38^\circ$ |
| $\cos \theta = .2321$. | | 6. $c = 20.15$ | 10. 24.64 ft |
| 2. $\sin \beta = .2321$; | $\cos P = \frac{12}{13}$. | 7. $b = 2.34$ | 11. 55.7° |
| $\cos \beta = .9727$. | 4. $b = 103.42$ | 8. $\angle A = 8.09^\circ$ | 12. .711 m |

§4.4: Interpreting dot products

- Suppose \mathbf{w} is a vector with magnitude 10. What is $\mathbf{w} \cdot \mathbf{w}$? What about $5\mathbf{w} \cdot \mathbf{w}$? What about $3\mathbf{w} \cdot 2\mathbf{w}$?
- Compute the angle between the vectors $\langle -4, 7 \rangle$ and $\langle -3, -5 \rangle$. Then, draw a picture to illustrate what you have computed.
- In each part of this problem, compute the angle between the two given vectors.

a) $\mathbf{v} = \langle 3, 7 \rangle$; $\mathbf{w} = \langle 11, 5 \rangle$	c) $\mathbf{a} = \langle -15, -17 \rangle$; $\mathbf{b} = \langle -20, -13 \rangle$
b) $\mathbf{u} = \langle -2, -5 \rangle$; $\mathbf{v} = \langle 1, 8 \rangle$	d) $\mathbf{v} = \langle 1, 2 \rangle$; $\mathbf{w} = \langle 5, -2 \rangle$
- Determine whether or not each pair of given vectors \mathbf{a} and \mathbf{b} are orthogonal:

a) $\mathbf{a} = \langle -15, -27 \rangle$; $\mathbf{b} = \langle 18, 10 \rangle$	c) $\mathbf{a} = \langle 12, 15 \rangle$; $\mathbf{b} = \langle -32, 40 \rangle$
b) $\mathbf{a} = \langle 8, 3 \rangle$; $\mathbf{b} = \langle 24, -9 \rangle$	d) $\mathbf{a} = \langle 1, -1 \rangle$; $\mathbf{b} = \langle -7, -7 \rangle$
- Suppose $\langle 5, -3 \rangle \perp \langle 2, y \rangle$. What must y be?
- In each part of this problem, you are given two vectors. Determine whether the angle between the two vectors is acute, obtuse or right:

a) $\mathbf{v} = \langle 8, 5 \rangle$; $\mathbf{w} = \langle -2, 9 \rangle$
b) $\mathbf{a} = \langle -3.72, -5.91 \rangle$; $\mathbf{b} = \langle 4.86, -4.32 \rangle$
c) \mathbf{u} and \mathbf{v} have unknown components, but $\mathbf{u} \cdot \mathbf{v} = 13$
d) \mathbf{a} and \mathbf{b} have unknown components, but $\mathbf{a} \cdot \mathbf{b} = -1.35$

Answers

- | | | |
|--|---------------------|--------------------|
| 1. $\mathbf{w} \cdot \mathbf{w} = 100$; | 2. 119.29° | b) 165.324° |
| $5\mathbf{w} \cdot \mathbf{w} = 500$; | | |
| $3\mathbf{w} \cdot 2\mathbf{w} = 600$. | 3. a) 42.36° | c) 15.55° |

8.5 Chapter 5 Homework

§5.3: Transformations on sine and cosine

Note: Every question in this section is NC.

In Exercises 1-27, sketch a graph of each indicated function.

1. $y = \sin x + 2$

10. $y = \sin 4x$

20. $y = \frac{2}{3} \cos \frac{x}{4}$

2. $y = \cos x - 1$

11. $y = \cos \frac{x}{3}$

21. $y = -6 \sin 5x$

3. $y = \sin x - \pi$

12. $y = \cos 2x$

22. $y = 2 \cos \left(x - \frac{\pi}{4} \right)$

4. $y = \sin(x - \pi)$

13. $y = \sin \frac{3x}{4}$

23. $y = 3 \sin 2x + 1$

5. $y = \cos \left(x - \frac{3\pi}{4} \right)$

14. $y = \cos \pi x$

24. $y = -\cos 4x + 2$

6. $y = \cos(x + \pi)$

15. $y = \sin \frac{\pi x}{7}$

25. $y = \frac{1}{4} \cos \frac{x}{3} - 1$

7. $y = \sin \left(x - \frac{\pi}{4} \right) + 3$

16. $y = 3 \sin x$

26. $y = -3 \sin \left(x + \frac{\pi}{2} \right) + 4$

8. $y = \cos \left(x + \frac{\pi}{2} \right) - 1$

17. $y = -2 \cos x$

18. $y = \frac{1}{5} \sin x$

9. $y = 2 + \sin \left(x + \frac{3\pi}{2} \right)$

19. $y = 4 \cos 2x$

27. $y = -2 \sin(3x + \pi) - 1$

In each of Exercises 28-33 below, you are given a function. Give the period of the function, and the highest and lowest y -values achieved by the graph of the function (you don't have to sketch a graph unless you think that would be helpful). For example, if you were given $y = \sin x$, the answer would be "the period is 2π , the highest y -value is 1 and the lowest y -value is -1 ".

28. $y = 3 \sin 2x$

30. $y = -5 \sin \frac{x}{4} - 2$

32. $y = \cos 3 \left(x - \frac{\pi}{4} \right) + 5$

29. $y = \cos x - 6$

31. $y = \frac{1}{4} \cos(x - \pi) + 1$

33. $y = \pi \sin \pi(x - \pi) + \pi$

34. Suppose that the graph of some function is obtained by taking $y = \cos x$, reflecting it across the x -axis, and shifting up 6 units.

a) Sketch the graph of this function.

b) What is the formula for this function?

35. Suppose that the graph of some function is obtained by taking $y = \sin x$, shifting it left 3 units and shifting it down 2 units.

- a) Sketch the graph of this function.
 - b) What is the formula for this function?
36. Suppose that the graph a sinusoidal function has period 6π , goes up as far as $y = 3$ and down as far as $y = 1$. The graph passes through the point $(5, 2)$, and is going up from left to right as it passes through $(5, 2)$.
- a) Sketch the graph of this function.
 - b) What is the formula for this function?

In Exercises 37-42, you are given the graph of some function. Your task is to write the equation of a function that has that graph. (In the solutions, I give the “easiest” solution, but be advised—there are many correct answers to each of these problems.)

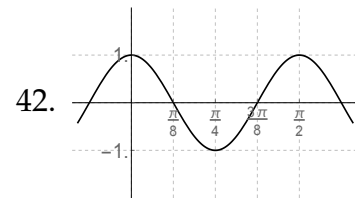
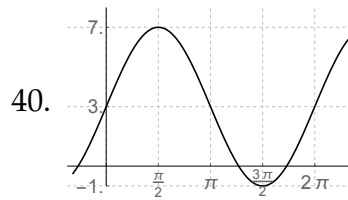
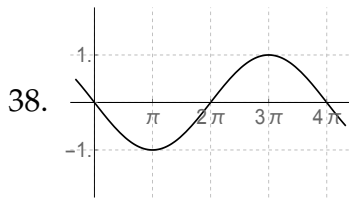
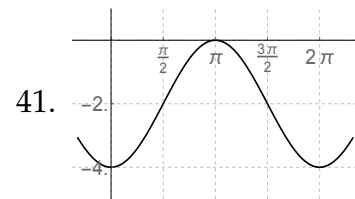
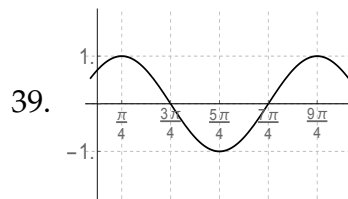
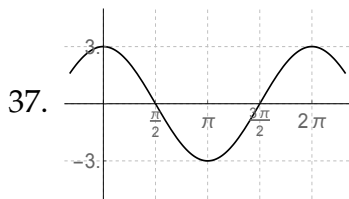

43. Suppose that the current (in amps) flowing through an electrical circuit at time x (in seconds) is modeled by a sinusoidal function. That function is shown here:

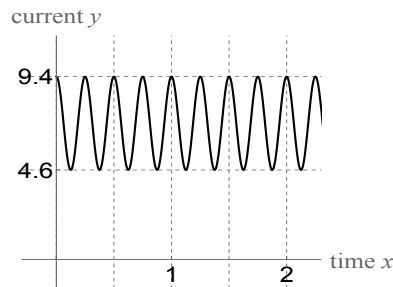

- a) Write an equation which gives the current in the circuit at time x .
- b) Use your equation to determine the current in the circuit at time $\frac{22}{3}$ seconds.

44. Over time (measured in hours), the size of a bacteria colony changes according to a sinusoidal function. A portion of the graph of that function is shown below:

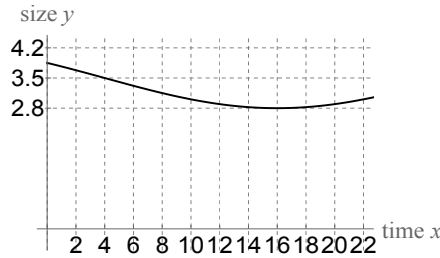

- What is the period of the function giving the size of the bacteria colony at time x ?
 - What is the amplitude of the function giving the size of the bacteria colony at time x ?
 - Write an equation which gives the size of the bacteria colony at time x .
 - Use your equation to determine the size of the bacteria colony at time 46.
45. A boat captain looks out at the water and sees waves that are modeled by the function graphed here:

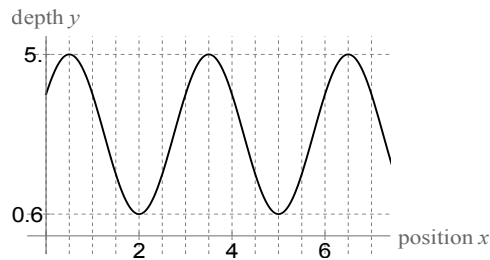

- Write an equation which gives the depth of the water at position x . (Assume the water depth is measured in feet.)
 - Use your equation to determine the water depth when $x = 15$.
 - Use your equation to determine the water depth when $x = -\frac{7}{4}$.
46. The power output (in kilowatts) of an electrical station at time x is given by a sinusoidal function. That function is graphed here:

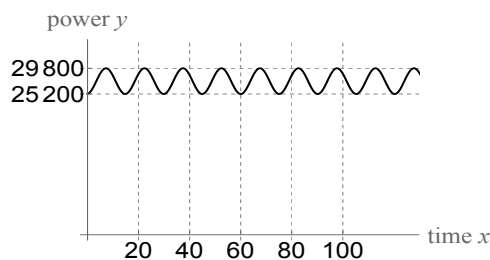

- a) What is the period of the function giving the power output of the station?
 b) Write an equation which gives the power output of the station at time x .
 c) Use your equation to determine the power output at time 24π .
47. a) Sketch the graphs of $y = \sin\left(x + \frac{\pi}{2}\right)$ and $y = \cos x$ on the same axes.
 b) What do you notice about these two graphs?
 c) What trig identity can be deduced based on your answer to part (b)?
48. a) Sketch the graphs of $y = \cos\left(x + \frac{\pi}{2}\right)$ and $y = \sin x$ on the same axes.
 b) What do you notice about these two graphs?
 c) What trig identity can be deduced based on your answer to part (b)?
49. Sketch the graph of $y = 2 \sin x \cos x$.

Hint: Use a trig identity to rewrite the formula for y before graphing.

In Problems 50-55, you are given a function and an alleged “graph” of that function. There is something very wrong with that graph; your task is to describe what’s wrong.

50. $y = 2 \sin x + 3$:

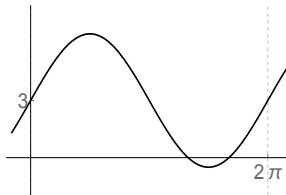

51. $y = \cos x - 3$:

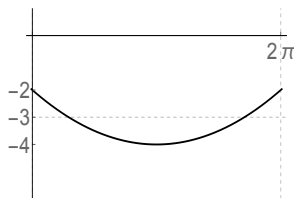

52. $y = -\cos(x - \pi)$:

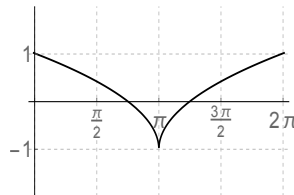

53. $y = -\sin x - 1$:

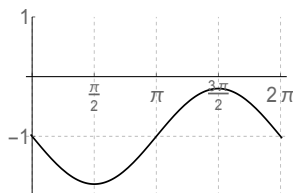

54. $y = \cos 3x$:

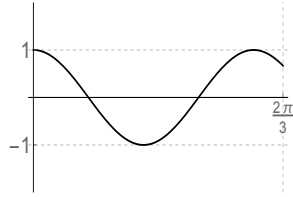

55. $y = \sin\left(x + \frac{\pi}{4}\right) + 2$:

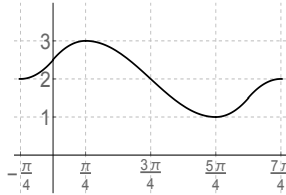

Answers

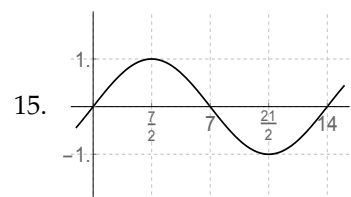
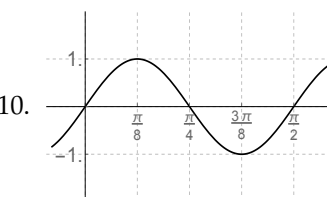
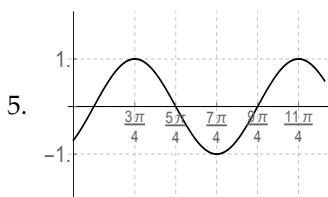
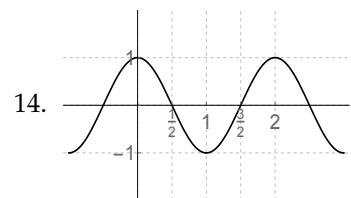
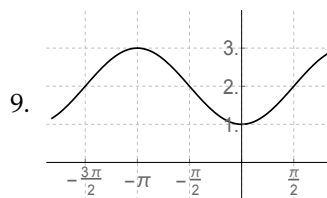
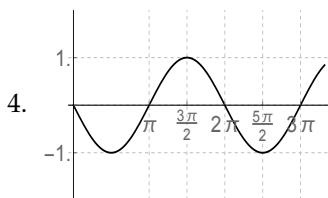
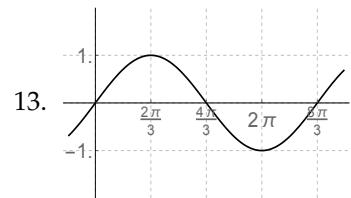
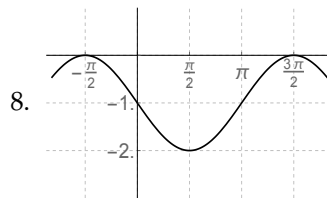
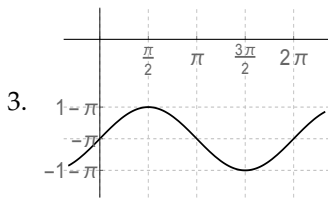
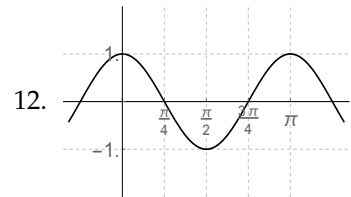
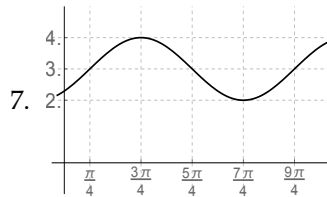
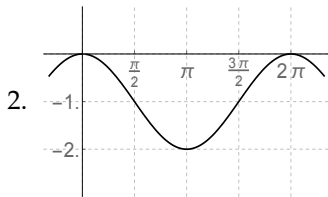
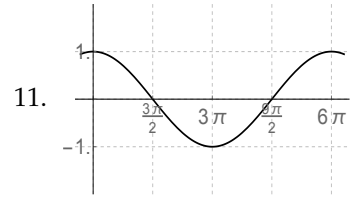
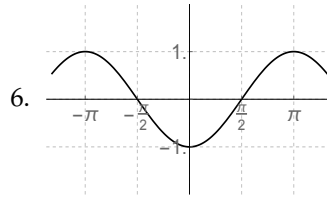
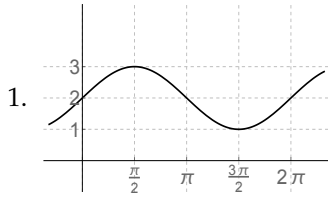

8.5. Chapter 5 Homework

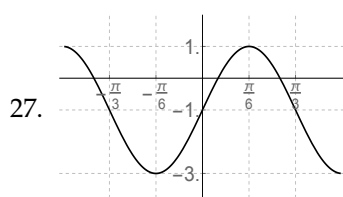
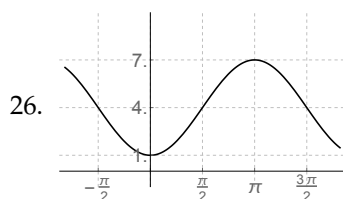
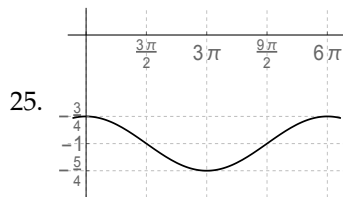
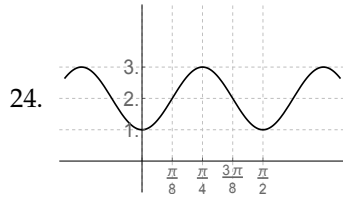
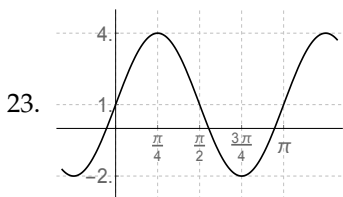
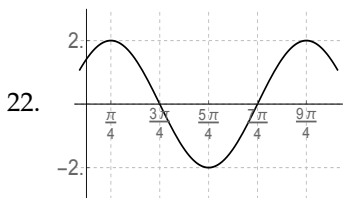
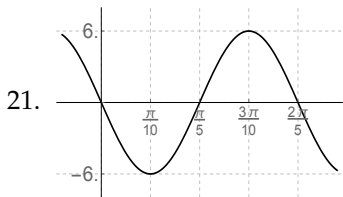
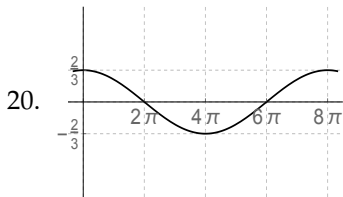
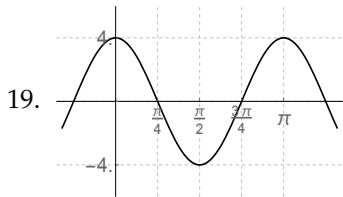
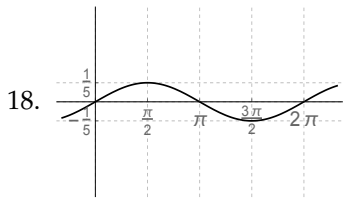
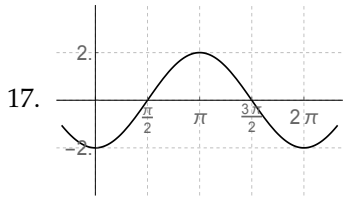
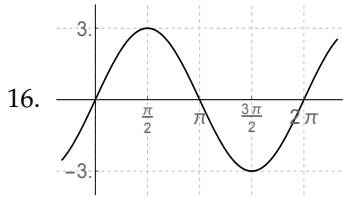

28. period π ;
highest y -value 3;
lowest y -value -3
29. period 2π ;
highest y -value -5 ;
lowest y -value -7
30. period 8π ;
highest y -value 3;
lowest y -value -7
31. period 2π ;
highest y -value $\frac{5}{4}$;
lowest y -value $\frac{3}{4}$
32. period $\frac{2\pi}{3}$;
highest y -value 8;
lowest y -value 2
33. period 2;
highest y -value 2π ;
lowest y -value 0

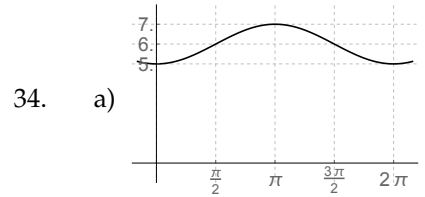

b) $y = -\cos x + 6$

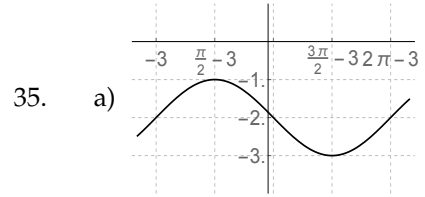

b) $y = \sin(x + 3) - 2$

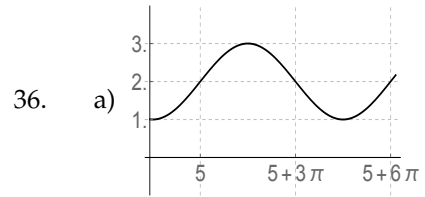

b) $y = \sin\left(\frac{1}{3}(x-5)\right) + \frac{1}{2}$

37. $y = 3 \cos x$
38. $y = -\sin \frac{x}{2}$
39. $y = \cos(x - \pi/4)$
40. $y = 4 \sin x + 3$
41. $y = -2 \cos x - 2$
42. $y = \cos 4x$
43. a) $y = 2.4 \cos 8\pi x + 7$
b) 5.8 A
44. a) $T = 48$ hrs
b) .7
c) $y = -.7 \sin \frac{\pi}{24}(x - 4) + 3.5$
d) $3.5 + .35\sqrt{2}$

8.5. Chapter 5 Homework

45. a) $y = -2.2 \cos \frac{2\pi}{3}(x - 2) + 2.8$
 b) 3.9 ft
 c) 2.8 ft

46. a) $T = \frac{24}{5}\pi$
 b) $y = 2300 \sin \frac{5}{12}(x - 4\pi) + 27500$
 c) $27500 + 1150\sqrt{3}$ kW

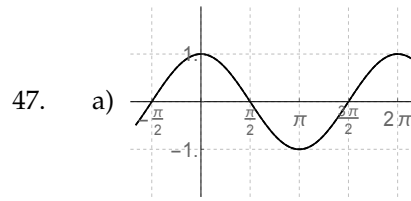

- b) They are the same graph.
 c) $\sin \left(x + \frac{\pi}{2}\right) = \cos x$.

48. a) The solid graph is $y = \cos \left(x + \frac{\pi}{2}\right)$; the dashed graph is $y = \sin x$:

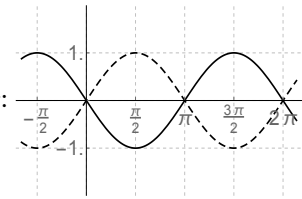

- b) Each one is a reflection across the x -axis of the other.
 c) $\cos \left(x + \frac{\pi}{2}\right) = -\sin x$.

49. This is the same as $y = \sin 2x$:

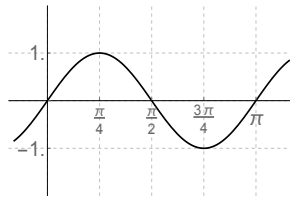

50. This graph goes beneath the x -axis, but the lowest y -value the function is supposed to hit is $y = 1$.
51. This cosine graph isn't flat at the beginning and end of its period.
52. This graph has a sharp corner in the middle.
53. This graph doesn't touch the x -axis, but the largest y -value the function hits is $y = 0$, so the graph should just touch the x -axis at $x = \frac{3\pi}{2}$.
54. This graph finishes one period before it gets to $x = \frac{2\pi}{3}$... see how it starts to go back down at the far right before $x = \frac{2\pi}{3}$? It is supposed to hit its peak exactly at the end of its period, which is $x = \frac{2\pi}{3}$.
55. The ends of this graph are wrong, because they start flat, like a parabola or cosine graph. Sine graphs should start with a positive slope (unless they are flipped over, in which case they should start with a negative slope); sine graphs should not start out and end flat (cosine graphs start and end flat, but not sine graphs).

§5.4: The graph of $y = \tan x$

NC Sketch a graph of each indicated function:

1. $y = \tan x$

2. $y = -\tan x$

3. $y = \tan\left(x - \frac{\pi}{4}\right)$

Answers

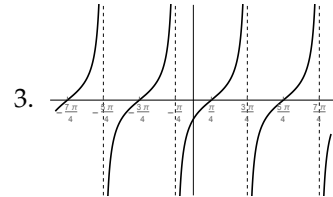
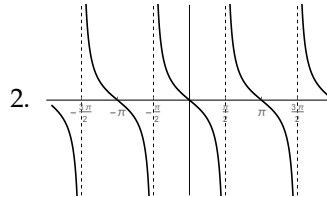
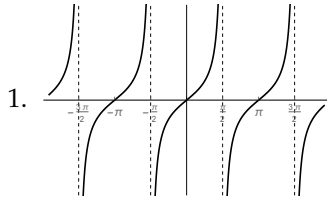

8.6 Chapter 6 Homework

§6.1: Definitions

- Suppose $\cot \theta = 2.315$. Compute $\tan \theta$.
 - Suppose $\cos \theta = .7$. Compute $\sec \theta$.
 - Suppose $\csc \theta = -3$. Compute $\sin \theta$.
- NC** In each problem, you are given the value of one trig function of θ . One of the **reciprocal identities** will immediately tell you the value of a second trig function of that θ . Write down what that trig function is, and what that trig function is equal to. (As an example, the solution to (a) would be " $\csc \theta = \frac{8}{7}$ ".)

 - $\sin \theta = \frac{7}{8}$
 - $\tan \theta = \frac{271}{135}$
 - $\csc \theta = -\frac{14}{9}$
 - $\cot \theta = -4$
 - $\cos \theta = .3$
 - $\tan \theta = -\frac{3}{5}$
- Evaluate each expression, using a calculator:
 - $\tan 242^\circ$
 - $\sec 72.5^\circ$
 - $\csc -106^\circ$
 - $\tan 42^\circ$
 - $\cot 15.65$
 - $\sec -2$
- Evaluate each expression, using a calculator:
 - $\tan^2 105^\circ$
 - $3 \csc 23^\circ$
 - $\sec 40^\circ - \csc 215^\circ$
 - $3 \cot^3 37^\circ \sin 99^\circ$
 - $4 + \tan 3 - 1$
 - $\cos 4 \cdot 2 + \sec 3 \cdot 5$
 - $\cos 1 \tan 1$
 - $\cos \tan 1$
- NC** Suppose $(\frac{9}{41}, -\frac{40}{41})$ is the point on the unit circle at angle θ .

 - What is $\sec \theta$?
 - What is $\csc \theta$?
 - What is $\tan \theta$?
 - What is $\cot \theta$?
- NC** Suppose $(-5, 12)$ is on the terminal side of θ when θ is drawn in standard position. Determine the values of all six trig functions of θ .
- Suppose $(-14.25, 8.73)$ is on the terminal side of θ when θ is drawn in standard position. Compute the values of all six trig functions of θ .
- NC** Suppose $(-8, -3)$ is on the terminal side of θ when θ is drawn in standard position. Compute $\tan \theta$ and $\csc \theta$.

9. NC OPT Suppose $(4, 5)$ is on the terminal side of θ when θ is drawn in standard position. Determine $\cot \theta$ and $\sec \theta$.
10. NC OPT Suppose $(2, -1)$ is on the terminal side of θ when θ is drawn in standard position. Compute $\tan \theta$ and $\sin \theta$.
11. NC Compute the six trig functions of angle θ , if θ is the acute angle from the positive x -axis to the line that passes through the origin and has slope 4.
12. Suppose $\sin \theta = \frac{7}{25}$ and $\cos \theta = -\frac{24}{25}$.
- What is $\tan \theta$?
 - What is $\cot \theta$?
13. Suppose $\cot \theta = -\frac{4}{3}$ and $\sin \theta = -\frac{3}{5}$. What is $\cos \theta$?
14. Suppose θ is some unknown angle so that $\cos \theta = a$ and $\sin \theta = b$.
- In terms of a and/or b , what is $\tan \theta$?
 - In terms of a and/or b , what is $\cot \theta$?
 - In terms of a and/or b , what is $\sec \theta$?
15. Suppose θ is some unknown angle so that $\cos \theta = p$ and $\cot \theta = q$.
- In terms of p and/or q , what is $\tan \theta$?
 - In terms of p and/or q , what is $\sin \theta$?
 - In terms of p and/or q , what is $\csc \theta$?
16. Right triangle ABC (with right angle at C has hypotenuse $c = 18$ and leg $a = 10.5$. Find the values of all six trig functions of angle A .
17. Determine the values of all six trig functions of θ , where θ is as pictured below:

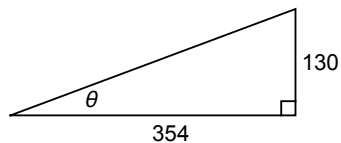

18. In each picture, write an equation for the quantity marked with a “?” in terms of the other given numbers and/or variables. Your equation should not contain division by anything other than a constant.

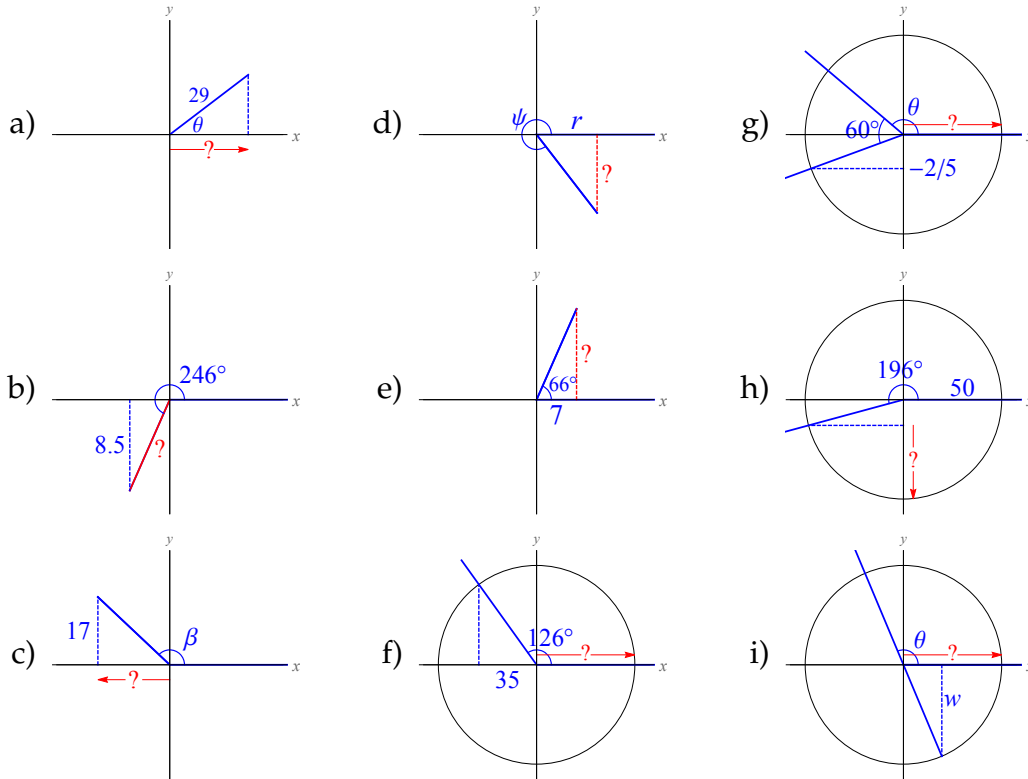

19. Suppose θ is an angle in a right triangle, and that two sides of this triangle are given. Write an equation for x in terms of θ and the other given quantity (your equation should not contain division).

- a) opposite side is 14, adjacent side is x
- b) adjacent side is q , hypotenuse is x
- c) hypotenuse is 10, adjacent side is x
- d) adjacent side is $3v$, opposite side is x

20. OPT Same directions as the previous problem:

- a) hypotenuse is $a + 4$, opposite side is x
- b) opposite side is 20, hypotenuse is x
- c) hypotenuse is 30, adjacent side is $x - 2$
- d) adjacent side is $2w$, opposite side is $\frac{x}{5}$

21. In each picture, write an equation for x in terms of the other given numbers and/or variables. Your equation should not contain division.

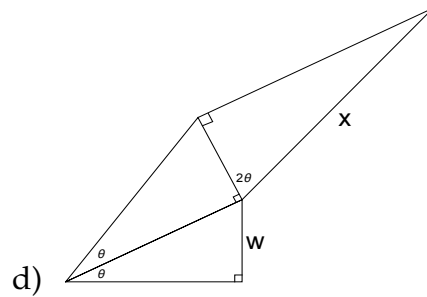
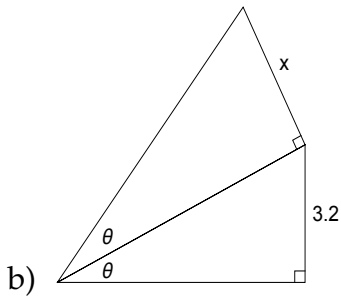
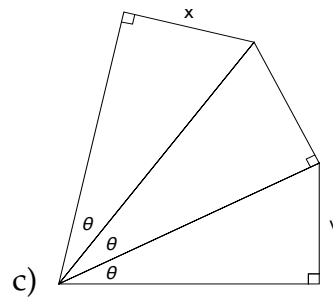
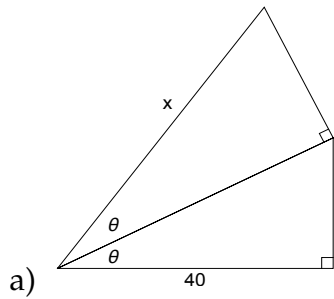

22. A 16-foot long ladder leans up against a building.
- Write an equation for the distance from the bottom of the ladder to the building, in terms of the angle the ladder makes with the ground.
 - Write an equation for the distance from the bottom of the ladder to the building, in terms of the angle the ladder makes with the side of the building.
 - Write an equation for the distance from the top of the ladder straight down to the ground, in terms of the angle the ladder makes with the ground.
 - Write an equation for the distance from the top of the ladder straight down to the ground, in terms of the angle the ladder makes with the side of the building.
23. A deer is 150 feet east of a hunter. The deer takes off running, at 40 feet per second, due north.
- How far north has the deer run t seconds after it starts running? Your answer should be in terms of t . (*Hint*: distance = rate \cdot time.)
 - Find the distance from the hunter to the deer t seconds after the deer starts running. Your answer should be in terms of t . (*Hint*: Pythagorean theorem.)
 - Suppose the angle at which the hunter views the deer is θ , measured north of east. How far north (in terms of θ) has the deer run?

- d) Suppose the angle at which the hunter views the deer is θ , measured north of east. How long (in terms of θ) has the deer been running?
24. Let x be the distance from A to B in the picture below. Write an equation for x , in terms of the other numbers and/or variables. (your equation should not contain division).

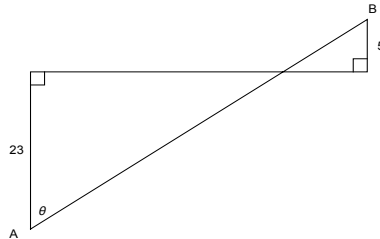

25. There is a 5 foot high wall 2 feet away from a house, running parallel to the house. Find the length of a ladder that leans up against the house, in terms of the angle the ladder makes with the side of the house, assuming that the ladder just brushes up against the top of the wall.
26. OPT A person is on a road that runs due north-south through a desert. He can drive a four-wheeler along the road at a speed of 50 mph, and can drive the four-wheeler off the road (in the desert) at 30 mph. He wants to get to a point that is 170 miles north and 100 miles east of his current location. To get there, he will drive some number of miles north on the road, then turn at angle θ (measured east of north) and drive directly toward his final destination. In terms of θ , compute these quantities:
- What distance will he drive on the road?
 - What distance will he drive off the road?
 - What amount of time will he spend driving on the road?
 - What amount of time will he spend driving off the road?
 - What is the total amount of time he will spend reaching his destination?

Answers

1. a) $\tan \theta = .432$ b) $\sec \theta = 1.4286$ c) $\sin \theta = -\frac{1}{3}$
2. a) $\csc \theta = \frac{8}{7}$ b) $\cot \theta = \frac{135}{271}$ c) $\sin \theta = -\frac{9}{14}$ d) $\tan \theta = -\frac{1}{4}$ e) $\sec \theta = \frac{10}{3}$ f) $\cot \theta = -\frac{5}{3}$
3. a) $\tan 242^\circ = 1.88073$ b) $\sec 72.5^\circ = 3.32551$ c) $\csc -106^\circ = -1.0403$ d) $\tan 42^\circ = .900404$ e) $\cot 15.65 = -17.233$ f) $\sec -2 = -2.403$
4. a) $\tan^2 105^\circ = 13.9282$ b) $3 \csc 23^\circ = 7.67791$ c) $\sec 40^\circ - \csc 215^\circ = 3.04885$ d) $3 \cot^3 37^\circ \sin 99^\circ = 6.92465$ e) $4 + \tan 3 - 1 = 2.85745$ f) $\cos 4 \cdot 2 + \sec 3 \cdot 5 = -1.46183$ g) $\cos 1 \tan 1 = .841741$ h) $\cos \tan 1 = .0133882$
5. a) $\sec \theta = \frac{41}{9}$ b) $\csc \theta = -\frac{41}{40}$ c) $\tan \theta = -\frac{40}{9}$ d) $\cot \theta = -\frac{9}{40}$
6. $\sin \theta = \frac{12}{13}$; $\cos \theta = -\frac{5}{13}$; $\tan \theta = -\frac{12}{5}$; $\cot \theta = -\frac{5}{12}$; $\sec \theta = -\frac{13}{5}$; $\csc \theta = \frac{13}{12}$.
7. $\sin \theta = .522394$; $\cos \theta = -.852704$; $\tan \theta = -.612632$; $\cot \theta = -1.6323$; $\sec \theta = -1.17274$; $\csc \theta = 1.91427$
8. $\tan \theta = \frac{3}{8}$; $\csc \theta = -\frac{\sqrt{73}}{3}$
9. $\cot \theta = \frac{4}{5}$; $\sec \theta = \frac{\sqrt{41}}{4}$
10. $\tan \theta = -\frac{1}{2}$; $\sin \theta = -\frac{1}{\sqrt{5}}$
11. $\tan \theta = 4$; $\cot \theta = \frac{1}{4}$; $\sin \theta = \frac{4}{\sqrt{17}}$; $\cos \theta = \frac{1}{\sqrt{17}}$; $\csc \theta = \frac{\sqrt{17}}{4}$; $\sec \theta = \sqrt{17}$
12. a) $\tan \theta = -\frac{7}{24}$ b) $\cot \theta = -\frac{24}{7}$
13. $\cos \theta = \frac{4}{5}$
14. a) $\tan \theta = \frac{b}{a}$ b) $\cot \theta = \frac{a}{b}$ c) $\sec \theta = \frac{1}{a}$
15. a) $\tan \theta = \frac{1}{q}$ b) $\sin \theta = \frac{p}{q}$ c) $\csc \theta = \frac{q}{p}$
16. $\sin A = .58333$; $\cos A = .812233$; $\tan A = .718185$; $\cot A = 1.3924$; $\sec A = 1.23117$; $\csc A = 1.71429$
17. $\sin \theta = .344722$; $\cos \theta = .938705$; $\tan \theta = .367232$; $\cot \theta = 2.72308$; $\sec \theta = 1.0653$; $\csc \theta = 2.90089$

18. a) $29 \cos \theta$ d) $r \tan \psi$ g) $-\frac{2}{5} \csc(\theta + 60^\circ)$
 b) $-8.5 \csc 246^\circ$ e) $7 \tan 66^\circ$ h) $50 \sin 196^\circ - 50$
 c) $17 \cot \beta$ f) $-35 \sec 126^\circ$ i) $w \csc(\theta + 180^\circ)$
19. a) $x = 14 \cot \theta$ b) $x = q \sec \theta$ c) $x = 10 \cos \theta$ d) $x = 3v \tan \theta$
20. a) $x = (a + 4) \sin \theta$ c) $x = 2 + 30 \sin \theta$
 (parentheses are important) (or $x = 30 \sin \theta + 2$)
 b) $x = 20 \csc \theta$ d) $x = 10w \tan \theta$
21. a) $x = 40 \sec^2 \theta$
 b) $x = 3.2 \csc \theta \tan \theta$
 (this simplifies to $3.2 \sec \theta$, but you don't need to know that yet).
 c) $x = v \csc \theta \sec \theta \sin \theta$
 (this simplifies to $x = v \sec \theta$, but you don't need to know that yet).
 d) $x = w \csc \theta \tan \theta \cos 2\theta$.
22. Throughout this problem, I called x the distance from the bottom of the ladder to the building, I called y the distance from the top of the ladder straight down to the ground, I called θ the angle between the bottom of the ladder and the ground, and I called ϕ the angle between the top of the ladder and the side of the building. But it doesn't matter what letters you choose.
- a) $x = 16 \cos \theta$ ft b) $x = 16 \sin \phi$ ft c) $y = 16 \sin \theta$ d) $y = 16 \cos \phi$
23. a) $40t$ ft c) $150 \tan \theta$ ft
 b) $\sqrt{150^2 + (40t)^2} = \sqrt{1600t + 22500}$ ft d) $\frac{150}{40} \tan \theta = 3.5 \tan \theta$ sec
24. $x = 23 \sec \theta + 5 \sec \theta = 28 \sec \theta$
25. $L = 5 \csc \theta + 2 \sec \theta$ ft
26. a) $170 - 100 \cot \theta$ mi d) $\frac{100 \csc \theta}{30} = 3.333 \csc \theta$ hrs
 b) $100 \csc \theta$ mi
 c) $\frac{170 - 100 \cot \theta}{50} = 3.2 - 2 \cot \theta$ hrs e) $3.2 - 2 \cot \theta + 3.333 \csc \theta$ hrs

§6.2: More on secant, cosecant and cotangent

1. For each equation, find all angles between 0° and 360° that solve the equation:
- a) $\cos \theta = .56$ d) $\cot \theta = .635$ g) $\csc \theta = \frac{4}{5}$
 b) $\cot \theta = -\frac{3}{8}$ e) $\sec \theta = -\frac{9}{14}$ h) $\tan \theta = -2.3$
 c) $\tan \theta = \frac{3}{7}$ f) $\csc \theta = -1$ i) $\sin \theta = -.43$

2. For each equation, find all angles between 0° and 360° that solve the equation:

a) $\tan \theta = 3.65$

c) $\sec \theta = 1.8$

e) $\csc \theta = \frac{17}{11}$

b) $\cot \theta = 2.31$

d) $\tan \theta = \frac{3}{13}$

f) $\tan \theta = 1.482$

3. **OPT** For each equation, find all angles between 0° and 360° that solve the equation:

a) $\csc \theta = \frac{11}{8}$

c) $\csc \theta = 1$

e) $\csc \theta = 0$

b) $\cot \theta = 4.35$

d) $\sec \theta = 1.1$

f) $\tan \theta = -\frac{1}{8}$

4. **NC** Classify each quantity as positive or negative:

a) $\cos 193^\circ$

d) $\tan 282^\circ$

g) $\sec 350^\circ$

b) $\sec -200^\circ$

e) $\cot 243^\circ$

h) $\sin 740^\circ$

c) $\csc 115^\circ$

f) $\tan 161.25^\circ$

i) $\tan -33^\circ$

5. **NC** Classify each quantity as positive or negative:

a) $\cos 385^\circ \tan 100^\circ$

c) $-\sin 128^\circ \csc 222^\circ$

b) $4 \sec^2 200^\circ$

d) $\frac{-3 \cos 100^\circ \csc -190^\circ}{4 \tan 95^\circ \sec 2 \cdot 150^\circ}$

6. **NC** In each part of this exercise, use the given information to determine what quadrant (or quadrants) θ could be in:

a) $\sec \theta < 0$

f) $\cot \theta > 0$ and $\csc \theta < 0$

b) $\tan \theta > 0$

g) $\cot \theta < 0$ and $\tan \theta < 0$

c) $\sin \theta < 0$

h) $\sec \theta > 0$ and $\cos \theta < 0$

d) $\csc \theta > 0$

i) $\sin \theta < 0$ and $\sec \theta > 0$

e) $\cos \theta > 0$ and $\tan \theta < 0$

j) $\tan \theta < 0$ and $\csc \theta < 0$

7. **NC** Suppose θ is in Quadrant II. Determine whether each of these quantities is positive or negative:

a) $\tan \theta$

b) $\sec \theta$

c) $\cot(-\theta)$

d) $\sec(90^\circ + \theta)$

8. **NC** Suppose θ is in Quadrant IV. Determine whether each of these quantities is positive or negative:

a) $\csc \theta$ b) $\sin(180^\circ + \theta)$ c) $\tan(180^\circ - \theta)$ d) $\cot(360^\circ + \theta)$

9. **NC** Suppose θ is in Quadrant I. Determine whether each of these quantities is positive or negative:

a) $\cos(180^\circ + \theta)$ b) $\csc(-\theta)$ c) $\csc(\theta - 90^\circ)$ d) $\csc(\theta + 180^\circ)$

Answers

1. a) $\theta = 55.94^\circ; \theta = 304.06^\circ$ d) $\theta = 57.58^\circ; \theta = 237.58^\circ$ h) $\theta = 113.5^\circ;$
 b) $\theta = 110.56^\circ;$ e) no solution $\theta = 293.5^\circ$
 $\theta = 290.56^\circ$ f) $\theta = 270^\circ$ i) $\theta = 205.47^\circ;$
 c) $\theta = 23.2^\circ; \theta = 203.2^\circ$ g) no solution $\theta = 334.53^\circ$
2. a) $\theta = 74.68^\circ; \theta = 254.68^\circ$ c) $\theta = 56.25^\circ; \theta = 303.75^\circ$ e) $\theta = 40.32^\circ; \theta = 139.68^\circ$
 b) $\theta = 23.41^\circ; \theta = 203.41^\circ$ d) $\theta = 13^\circ; \theta = 193^\circ$ f) $\theta = 55.99^\circ; \theta = 235.99^\circ$
3. a) $\theta = 46.65^\circ; \theta = 133.35^\circ$ d) $\theta = 24.62^\circ; \theta = 335.38^\circ$
 b) $\theta = 12.99^\circ; \theta = 192.99^\circ$ e) no solution
 c) $\theta = 90^\circ$ f) $\theta = 172.88^\circ; \theta = 352.88^\circ$
4. a) negative d) negative g) positive
 b) negative e) positive h) positive
 c) positive f) negative i) negative
5. a) negative b) positive c) positive d) negative
6. a) II or III d) I or II g) II or IV i) IV
 b) I or III e) IV h) this is not j) IV
 c) III or IV f) III possible
7. a) negative b) negative c) positive d) negative
8. a) negative b) positive c) positive d) negative
9. a) negative b) negative c) negative d) negative

§6.3: Trig functions of special angles

- NC** For each given angle, compute the values of all six trig functions of that angle:

- | | | |
|-----------------|--------------------|----------------------|
| 1. 270° | 3. 0 | 5. $-\frac{5\pi}{2}$ |
| 2. -180° | 4. $\frac{\pi}{2}$ | 6. 45° |

NC For each given angle, compute the values of all six trig functions of that angle:

- | | | | |
|---------------------|-----------------------|------------------|----------------------|
| 7. $\frac{5\pi}{4}$ | 9. 120° | 11. -270° | 13. $\frac{7\pi}{2}$ |
| 8. 300° | 10. $-\frac{5\pi}{6}$ | 12. 1110° | 14. $\frac{4\pi}{3}$ |

NC In each of Problems 15-26, compute the given quantity.

- | | | | |
|---------------------------|---------------------------|----------------------------|---------------------------|
| 15. $\tan \frac{\pi}{6}$ | 18. $\tan -\pi$ | 21. $\sin \frac{11\pi}{6}$ | 24. $\cot 3\pi$ |
| 16. $\cot \frac{4\pi}{3}$ | 19. $\cot \frac{\pi}{2}$ | 22. $\cos \frac{5\pi}{4}$ | 25. $\csc \frac{\pi}{6}$ |
| 17. $\sec 7\pi$ | 20. $\sec \frac{2\pi}{3}$ | 23. $\tan -\frac{\pi}{4}$ | 26. $\sec -\frac{\pi}{6}$ |

NC In each of Problems 27-38, compute the given quantity.

- | | | | |
|-----------------------|----------------------|-----------------------|----------------------|
| 27. $\tan -30^\circ$ | 30. $\cos -45^\circ$ | 33. $\cos -120^\circ$ | 36. $\cos 210^\circ$ |
| 28. $\csc 150^\circ$ | 31. $\sec 60^\circ$ | 34. $\tan 45^\circ$ | 37. $\csc 60^\circ$ |
| 29. $\sin -210^\circ$ | 32. $\tan 90^\circ$ | 35. $\tan 450^\circ$ | 38. $\sec -90^\circ$ |

OPT NC In each of Problems 39-50, compute the given quantity.

- | | | | |
|----------------------------|---------------------------|----------------------------|---------------------------|
| 39. $\sin -\frac{3\pi}{4}$ | 42. $\tan \frac{3\pi}{4}$ | 45. $\sin 0$ | 48. $\tan \frac{\pi}{2}$ |
| 40. $\cos -\frac{5\pi}{6}$ | 43. $\cot \frac{\pi}{3}$ | 46. $\tan -\frac{2\pi}{3}$ | 49. $\cos \frac{4\pi}{3}$ |
| 41. $\sec -\frac{\pi}{6}$ | 44. $\csc \pi$ | 47. $\cot 0$ | 50. $\csc \frac{\pi}{3}$ |

OPT NC In each of Problems 51-62, compute the given quantity.

- | | | | |
|----------------------|----------------------|-----------------------|-----------------------|
| 51. $\cot 270^\circ$ | 54. $\cot 300^\circ$ | 57. $\cot -135^\circ$ | 60. $\cot -360^\circ$ |
| 52. $\csc 225^\circ$ | 55. $\sec -90^\circ$ | 58. $\sin 600^\circ$ | 61. $\sec 180^\circ$ |
| 53. $\tan 30^\circ$ | 56. $\tan -60^\circ$ | 59. $\tan 480^\circ$ | 62. $\sin 135^\circ$ |

NC In each of Problems 63-71, compute the given quantity.

63. $\sec 150^\circ - \sec 30^\circ$ 67. $\sin^2 \frac{5\pi}{4}$ 70. $2 \csc \frac{7\pi}{2}$
 64. $\sec(150^\circ - 30^\circ)$ 68. $\cos \frac{7\pi}{4} \cot \left(\frac{\pi}{2} + \pi \right)$
 65. $\tan 3 \cdot 45^\circ$ 69. $3 \tan^3 540^\circ$ 71. $\tan \frac{5\pi}{6} \cot \frac{\pi}{4}$
 66. $\cot 12 \cdot \frac{\pi}{4}$

NC In each of Problems 72-80, compute the given quantity.

72. $3 - 2 \sin 150^\circ$ 75. $\tan^2 \frac{19\pi}{6}$ 78. $\cos \frac{3\pi}{2} \tan \frac{5\pi}{7}$
 73. $\cos 2 \cdot \frac{\pi}{3} + \cos 7 \cdot \frac{\pi}{6}$ 76. $\csc \frac{3\pi}{4} + \frac{\pi}{4}$ 79. $\frac{\sec^3 \frac{5\pi}{6}}{12}$
 74. $4 \sec \left(\frac{\pi}{3} + \frac{\pi}{3} + \frac{\pi}{3} \right)$ 77. $3 - 5 \tan (50^\circ - 5^\circ)$ 80. $\cos \tan \sin \pi$

Answers

- $\sin 270^\circ = -1$; $\cos 270^\circ = 0$; $\tan 270^\circ$ DNE; $\cot 270^\circ = 0$; $\csc 270^\circ = -1$; $\sec 270^\circ$ DNE
- $\sin -180^\circ = 0$; $\cos -180^\circ = -1$; $\tan -180^\circ = 0$; $\cot -180^\circ$ DNE; $\csc -180^\circ$ DNE;
 $\sec -180^\circ = -1$
- $\sin 0 = 0$; $\cos 0 = 1$; $\tan 0 = 0$; $\cot 0$ DNE; $\sec 0 = 1$; $\csc 0$ DNE
- $\sin \frac{\pi}{2} = 1$; $\cos \frac{\pi}{2} = 0$; $\tan \frac{\pi}{2}$ DNE; $\cot \frac{\pi}{2} = 0$; $\sec \frac{\pi}{2}$ DNE; $\csc \frac{\pi}{2} = 1$
- $\sin \frac{-5\pi}{2} = -1$; $\cos \frac{-5\pi}{2} = 0$; $\tan \frac{-5\pi}{2}$ DNE; $\cot \frac{-5\pi}{2} = 0$; $\csc \frac{-5\pi}{2} = -1$; $\sec \frac{-5\pi}{2}$ DNE
- $\sin 45^\circ = \frac{\sqrt{2}}{2}$; $\cos 45^\circ = \frac{\sqrt{2}}{2}$; $\tan 45^\circ = 1$; $\cot 45^\circ = 1$; $\sec 45^\circ = \frac{2}{\sqrt{2}} = \sqrt{2}$; $\csc 45^\circ = \frac{2}{\sqrt{2}} = \sqrt{2}$
- $\sin \frac{5\pi}{4} = -\frac{\sqrt{2}}{2}$; $\cos \frac{5\pi}{4} = -\frac{\sqrt{2}}{2}$; $\tan \frac{5\pi}{4} = 1$; $\cot \frac{5\pi}{4} = 1$; $\sec \frac{5\pi}{4} = -\sqrt{2}$; $\csc \frac{5\pi}{4} = -\sqrt{2}$
- $\sin 300^\circ = -\frac{\sqrt{3}}{2}$; $\cos 300^\circ = \frac{1}{2}$; $\tan 300^\circ = -\sqrt{3}$; $\cot 300^\circ = -\frac{1}{\sqrt{3}}$; $\sec 300^\circ = 2$;
 $\csc 300^\circ = -\frac{2}{\sqrt{3}}$
- $\sin 120^\circ = \frac{\sqrt{3}}{2}$; $\cos 120^\circ = -\frac{1}{2}$; $\tan 120^\circ = -\sqrt{3}$; $\cot 120^\circ = -\frac{1}{\sqrt{3}}$; $\sec 120^\circ = -2$;
 $\csc 120^\circ = \frac{2}{\sqrt{3}}$
- $\sin -\frac{5\pi}{6} = -\frac{1}{2}$; $\cos -\frac{5\pi}{6} = -\frac{\sqrt{3}}{2}$; $\tan -\frac{5\pi}{6} = \frac{1}{\sqrt{3}}$; $\cot -\frac{5\pi}{6} = \sqrt{3}$; $\sec -\frac{5\pi}{6} = -\frac{2}{\sqrt{3}}$;
 $\csc -\frac{5\pi}{6} = -2$.
- $\sin -270^\circ = 1$; $\cos -270^\circ = 0$; $\tan -270^\circ$ DNE; $\cot -270^\circ = 0$; $\sec -270^\circ$ DNE; $\csc -270^\circ = 1$.
- $\sin 1110^\circ = \frac{1}{2}$; $\cos 1110^\circ = \frac{\sqrt{3}}{2}$; $\tan 1110^\circ = \frac{1}{\sqrt{3}}$; $\cot 1110^\circ = \sqrt{3}$; $\sec 1110^\circ = \frac{2}{\sqrt{3}}$;
 $\csc 1110^\circ = 2$.
- $\sin \frac{7\pi}{2} = -1$; $\cos \frac{7\pi}{2} = 0$; $\tan \frac{7\pi}{2}$ DNE; $\cot \frac{7\pi}{2} = 0$; $\sec \frac{7\pi}{2}$ DNE; $\csc \frac{7\pi}{2} = -1$.
- $\sin \frac{4\pi}{3} = -\frac{\sqrt{3}}{2}$; $\cos \frac{4\pi}{3} = -\frac{1}{2}$; $\tan \frac{4\pi}{3} = \sqrt{3}$; $\cot \frac{4\pi}{3} = \frac{1}{\sqrt{3}}$; $\sec \frac{4\pi}{3} = -2$; $\csc \frac{4\pi}{3} = -\frac{2}{\sqrt{3}}$.

15. $\tan \frac{\pi}{6} = \frac{1}{\sqrt{3}}$
16. $\cot \frac{4\pi}{3} = \frac{1}{\sqrt{3}}$
17. $\sec 7\pi = -1$
18. $\tan -\pi = 0$
19. $\cot \frac{\pi}{2} = 0$
20. $\sec \frac{2\pi}{3} = -2$
21. $\sin \frac{11\pi}{6} = -\frac{1}{2}$
22. $\cos \frac{5\pi}{4} = -\frac{\sqrt{2}}{2}$
23. $\tan -\frac{\pi}{4} = -1$
24. $\cot 3\pi$ DNE
25. $\csc \frac{\pi}{6} = 2$
26. $\sec -\frac{\pi}{6} = \frac{2}{\sqrt{3}}$
27. $\tan -30^\circ = -\frac{1}{\sqrt{3}}$
28. $\csc 150^\circ = 2$
29. $\sin -210^\circ = -\frac{1}{2}$
30. $\cos -45^\circ = \frac{\sqrt{2}}{2}$
31. $\sec 60^\circ = 2$
32. $\tan 90^\circ$ DNE
33. $\cos -120^\circ = -\frac{1}{2}$
34. $\tan 45^\circ = 1$
35. $\tan 450^\circ$ DNE
36. $\cos 210^\circ = -\frac{\sqrt{3}}{2}$
37. $\csc 60^\circ = \frac{2}{\sqrt{3}}$
38. $\sec -90^\circ$ DNE
39. $\sin -\frac{3\pi}{4} = -\frac{\sqrt{2}}{2}$
40. $\cos -\frac{5\pi}{6} = -\frac{\sqrt{3}}{2}$
41. $\sec -\frac{\pi}{6} = \frac{2}{\sqrt{3}}$
42. $\tan \frac{3\pi}{4} = -1$
43. $\cot \frac{\pi}{3} = \frac{1}{\sqrt{3}}$
44. $\csc \pi$ DNE
45. $\sin 0 = 0$
46. $\tan -\frac{2\pi}{3} = \sqrt{3}$
47. $\cot 0$ DNE
48. $\tan \frac{\pi}{2}$ DNE
49. $\cos \frac{4\pi}{3} = -\frac{1}{2}$
50. $\csc \frac{\pi}{3} = \frac{2}{\sqrt{3}}$
51. $\cot 270^\circ = 0$
52. $\csc 225^\circ = -\sqrt{2}$
53. $\tan 30^\circ = \frac{1}{\sqrt{3}}$
54. $\cot 300^\circ = -\frac{1}{\sqrt{3}}$
55. $\sec -90^\circ$ DNE
56. $\tan -60^\circ = -\sqrt{3}$
57. $\cot -135^\circ = -1$
58. $\sin 600^\circ = \frac{\sqrt{3}}{2}$
59. $\tan 480^\circ = -\sqrt{3}$
60. $\cot -360^\circ$ DNE
61. $\sec 180^\circ = -1$
62. $\sin 135^\circ = \frac{\sqrt{2}}{2}$
63. $\sec 150^\circ - \sec 30^\circ = -\frac{4}{\sqrt{3}}$
64. $\sec(150^\circ - 30^\circ) = -2$
65. $\tan 3 \cdot 45^\circ = 1$
66. $\cot 12 \cdot \frac{\pi}{4}$ DNE
67. $\sin^2 \frac{5\pi}{4} = \frac{1}{2}$
68. $\cos \frac{7\pi}{4} \cot \left(\frac{\pi}{2} + \pi \right) = 0$
69. $3 \tan^3 540^\circ = 0$
70. $2 \csc \frac{7\pi}{2} = -2$
71. $\tan \frac{5\pi}{6} \cot \frac{\pi}{4} = -\frac{1}{\sqrt{3}}$
72. $3 - 2 \sin 150^\circ = 2$
73. $\cos 2 \cdot \frac{\pi}{3} + \cos 7 \cdot \frac{\pi}{6} = \frac{-1 - \sqrt{3}}{2}$
74. $4 \sec \left(\frac{\pi}{3} + \frac{\pi}{3} + \frac{\pi}{3} \right) = -4$
75. $\tan^2 \frac{19\pi}{6} = \frac{1}{3}$
76. $\csc \frac{3\pi}{4} + \frac{\pi}{4} = \frac{2}{\sqrt{2}} + \frac{\pi}{4}$
77. $3 - 5 \tan(50^\circ - 5^\circ) = -2$
78. $\cos \frac{3\pi}{2} \tan \frac{5\pi}{7} = 0$
79. $\frac{\sec^3 \frac{5\pi}{6}}{12} = \frac{2}{9\sqrt{3}}$
80. $\cos \tan \sin \pi = 1$

§6.4: Pythagorean identities

1. NC Suppose $\tan \theta = \frac{2}{5}$ and $\cos \theta < 0$. Find the values of all six trig functions of θ .
2. NC Suppose $\csc \theta = 4$ and $\sec \theta < 0$. Find the values of all six trig functions

- of θ .
- Suppose $\cos \theta = .7$ and $\cot \theta < 0$. Find the values of all six trig functions of θ .
 - Suppose $\cot \theta = -2.35$ and $\sin \theta > 0$. Find $\cos \theta$ and $\sec \theta$.
 - NC** Suppose (x, y) is the point on the unit circle at angle θ .
 - What is $\tan(-\theta)$?
 - What is $\sec(-\theta)$?
 - What is $\cot(\theta - 180^\circ)$?
 - What is $\sec(180^\circ - \theta)$?
 - What is $\csc(180^\circ - \theta)$?
 - What is $\tan(\theta + 90^\circ)$?
 - What is $\sec(\theta - 90^\circ)$?
 - What is $\cot(\theta + 720^\circ)$?
 - If $\tan \theta = 4$, what is $\tan(-\theta)$?
 - If $\cot \theta = -.54$, what is $\cot(-\theta)$?
 - If $\sec \theta = \frac{1}{3}$, what is $\sec(-\theta)$? What about $\cos(-\theta)$?
 - If $\cos \theta = z$, what is $\cos(-\theta)$?
 - If $\csc \theta = 6w$, what is $\csc(-\theta)$? What about $\sin(-\theta)$?
 - NC** Compute each quantity:
 - $\tan^2 \frac{3\pi}{7} - \sec^2 \frac{3\pi}{7}$
 - $\csc 18^\circ + \csc(-18^\circ)$
 - $\sec 48^\circ - \sec 408^\circ$
 - $\cos 70^\circ - \sin 20^\circ$
 - $\cos^2 200^\circ + \sin^2 200^\circ$
 - $3 \sin^2 5^\circ + 3 \cos^2 5^\circ$
 - NC** Compute each quantity:
 - $\cos 100^\circ - \cos 260^\circ$
 - $\cot^2 800^\circ - \csc^2 800^\circ$
 - $\cos 130^\circ - \cos(-230^\circ)$
 - $\sec^2 \frac{8\pi}{9} - \tan^2 \frac{8\pi}{9}$
 - $\sin^2 \frac{\pi}{5} + \cos^2 \frac{\pi}{5}$
 - $\tan 40^\circ - \tan 220^\circ$

Answers

- $\sin \theta = -\frac{2}{\sqrt{29}}$; $\cos \theta = -\frac{5}{\sqrt{29}}$; $\tan \theta = \frac{2}{5}$; $\cot \theta = \frac{5}{2}$; $\sec \theta = -\frac{\sqrt{29}}{5}$; $\csc \theta = -\frac{\sqrt{29}}{2}$.
- $\sin \theta = \frac{1}{4}$; $\cos \theta = -\frac{\sqrt{15}}{4}$; $\tan \theta = -\frac{1}{\sqrt{15}}$; $\cot \theta = -\sqrt{15}$; $\sec \theta = -\frac{4}{\sqrt{15}}$; $\csc \theta = 4$.
- $\sin \theta = -.714143$; $\cos \theta = .7$; $\tan \theta = -1.0202$; $\cot \theta = -.980196$; $\sec \theta = 1.42857$; $\csc \theta = -1.40028$.
- $\cos \theta = -.920155$; $\sec \theta = -1.08677$.

5. a) $\tan(-\theta) = -\frac{y}{x}$ e) $\csc(180^\circ - \theta) = \frac{\sqrt{x^2 + y^2}}{y}$
 b) $\sec(-\theta) = \frac{\sqrt{x^2 + y^2}}{x}$ f) $\tan(\theta + 90^\circ) = -\frac{x}{y}$
 c) $\cot(\theta - 180^\circ) = \frac{x}{y}$ g) $\sec(\theta - 90^\circ) = \frac{\sqrt{x^2 + y^2}}{y}$
 d) $\sec(180^\circ - \theta) = -\frac{\sqrt{x^2 + y^2}}{x}$ h) $\cot(\theta + 720^\circ) = \frac{x}{y}$
6. a) $\tan(-\theta) = -4$ c) $\sec(-\theta) = \frac{1}{3};$ e) $\csc(-\theta) = -6w;$
 $\cos(-\theta) = 3.$
 b) $\cot(-\theta) = .54$ d) $\cos(-\theta) = z$ $\sin(-\theta) = -\frac{1}{6w}.$
7. a) $\tan^2 \frac{3\pi}{7} - \sec^2 \frac{3\pi}{7} = -1$ d) $\cos 70^\circ - \sin 20^\circ = 0$
 b) $\csc 18^\circ + \csc(-18^\circ) = 0$ e) $\cos^2 200^\circ + \sin^2 200^\circ = 1$
 c) $\sec 48^\circ - \sec 408^\circ = 0$ f) $3 \sin^2 5^\circ + 3 \cos^2 5^\circ = 3$
8. a) $\cos 100^\circ - \cos 260^\circ = 0$ d) $\sec^2 \frac{8\pi}{9} - \tan^2 \frac{8\pi}{9} = 1$
 b) $\cot^2 800^\circ - \csc^2 800^\circ = -1$ e) $\sin^2 \frac{\pi}{5} + \cos^2 \frac{\pi}{5} = 1$
 c) $\cos 130^\circ - \cos(-230^\circ) = 0$ f) $\tan 40^\circ - \tan 220^\circ = 0$

§6.5: Graphs of cosecant, secant and cotangent

NC Sketch a graph of each indicated function:

1. $y = \csc x$ 3. $y = \tan x$ 5. $y = \csc 2x$ 7. $y = \csc x + 3$
 2. $y = \cot x$ 4. $y = \sec x$ 6. $y = 4 \sec x$

Answers

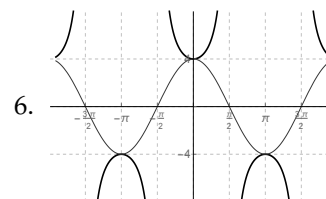
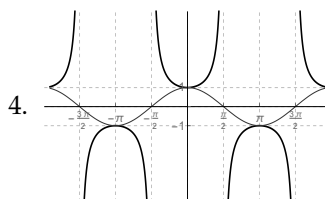
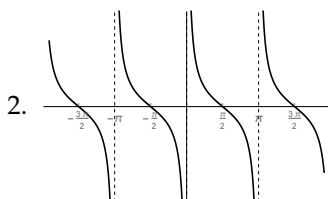
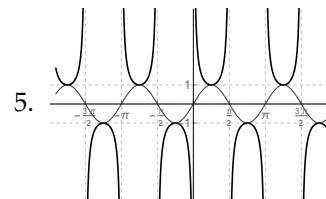
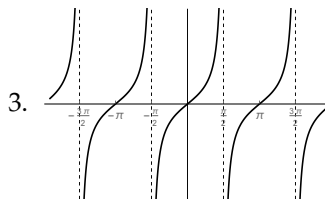
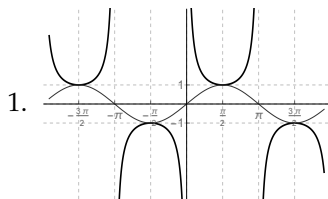

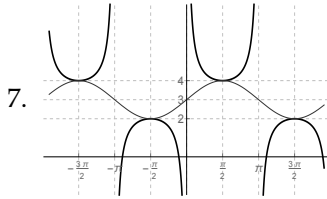

8.7 Chapter 7 Homework

§7.1: Elementary trig identities

Note: Every question in this section is NC.

1.
 - a) Rewrite the expression $\tan^2 \theta$ in terms of only the trig function $\sec \theta$.
 - b) Rewrite the expression $\csc^2 \theta$ in terms of only the trig function $\cot \theta$.
 - c) Rewrite the expression $2 \cos^2 \theta$ in terms of only the trig function $\sin \theta$.
2.
 - a) Rewrite the expression $2 \sec^2 \theta + 3$ in terms of only the trig function $\tan \theta$.
 - b) Rewrite the expression $2 \csc^2 \theta - 4 \cot^2 \theta$ in terms of only the trig function $\csc \theta$.
 - c) Rewrite the expression $2 \sin^2 \theta + 3 \cos^2 \theta$ in terms of only the trig function $\sin \theta$.
 - d) Rewrite the expression $2 \sin^2 \theta + 3 \cos^2 \theta$ in terms of only the trig function $\cos \theta$.

In each part of Exercises 3-6, determine if each given expression can be simplified into a single term. If so, simplify it; otherwise, do nothing.

3.

a) $\sin^2 \theta - \cos^2 \theta$	b) $\tan^2 \theta + 1$	c) $\cot^2 \theta + 1$	d) $1 - \sec^2 \theta$
------------------------------------	------------------------	------------------------	------------------------
4.

a) $1 - \tan^2 \theta$	b) $\csc^2 \theta - 1$	c) $\cos^2 \theta + \cot^2 \theta$	d) $\sec^2 \theta - \csc^2 \theta$
------------------------	------------------------	------------------------------------	------------------------------------
5.

a) $\sin^2 \theta - 1$	b) $\cot^2 \theta - \csc^2 \theta$	c) $\cos^2 \theta + \cot^2 \theta$	d) $\sec^2 \theta - \csc^2 \theta$
------------------------	------------------------------------	------------------------------------	------------------------------------
6.

a) $1 - \cos^2 \theta$	b) $1 + \sin^2 \theta$	c) $\cot^2 \theta - 1$	d) $\sec^2 \theta - \tan^2 \theta$
------------------------	------------------------	------------------------	------------------------------------

In each of Exercises 7-19, simplify each expression as much as possible, and write your answer so that no quotients appear in the final answer, and no $-$ signs are inside trig functions:

- | | | |
|---|---|---|
| 7. $\sec \theta \cot \theta$ | 12. $\frac{\tan(-\theta)}{\cot(-\theta)}$ | 17. $\frac{1 - \csc^2 \theta}{\sec^2 \theta - 1}$ |
| 8. $\csc(-\theta) \cos \theta$ | 13. $\sin \theta \tan \theta - \sec \theta$ | |
| 9. $\csc \theta \tan \theta$ | 14. $\sin \theta(\csc \theta - \sin \theta)$ | 18. $\frac{1 + \tan(-\theta)}{\tan(-\theta)}$ |
| 10. $\frac{\sin \theta}{\csc \theta}$ | 15. $\frac{\csc(-\theta)}{\cot \theta}$ | |
| 11. $\frac{\sec(-\theta)}{\csc \theta}$ | 16. $\frac{1 + \tan^2(-\theta)}{1 + \cot^2 \theta}$ | 19. $\frac{1 - \cos^2 \theta}{1 + \tan^2 \theta}$ |

In each of Exercises 20-28, verify that each equation is an identity:

- | | |
|---|---|
| 20. $\sec \theta = \csc \theta \tan \theta$ | 25. $\frac{1 + \cos(-\theta)}{\sin \theta} = \frac{\tan \theta}{\sec \theta - 1}$ |
| 21. $\sin \theta(\sec \theta + \csc \theta) - 1 = \tan \theta$ | 26. $\sec \theta - \csc \theta = \frac{\sin \theta - \cos \theta}{\sin \theta \cos \theta}$ |
| 22. $\sec(-\theta) \cot \theta \sin \theta = 1$ | 27. $\sec^4 \theta - \sec^2 \theta = \tan^4 \theta + \tan^2 \theta$ |
| 23. $\csc \theta = \sin \theta + \cot \theta \cos \theta$ | 28. $\frac{\tan(-\theta)}{\sec(-\theta)} = \sin(-\theta)$ |
| 24. $\frac{\sin \theta}{1 + \cos \theta} = \frac{1 - \cos \theta}{\sin \theta}$ | |

Answers

- | | |
|---|---|
| 1. a) $\tan^2 \theta = \sec^2 \theta - 1$. | b) $\cot^2 \theta - \csc^2 \theta = -1$. |
| b) $\csc^2 \theta = \cot^2 \theta + 1$. | c) $\cos^2 \theta + \cot^2 \theta$ can't be simplified. |
| c) $2 \cos^2 \theta = 2 - 2 \sin^2 \theta$. | d) $\sec^2 \theta - \csc^2 \theta$ can't be simplified. |
| 2. a) $2 \sec^2 \theta + 3 = 2 \tan^2 \theta + 5$. | 6. a) $1 - \cos^2 \theta = \sin^2 \theta$. |
| b) $2 \csc^2 \theta - 4 \cot^2 \theta = -2 \csc^2 \theta + 4$. | b) $1 + \sin^2 \theta$ can't be simplified. |
| c) $2 \sin^2 \theta + 3 \cos^2 \theta = 3 - \sin^2 \theta$. | c) $\cot^2 \theta - 1$ can't be simplified. |
| d) $2 \sin^2 \theta + 3 \cos^2 \theta = 2 + \cos^2 \theta$. | d) $\sec^2 \theta - \tan^2 \theta = 1$. |
| 3. a) $\sin^2 \theta - \cos^2 \theta$ can't be simplified | 7. $\sec \theta \cot \theta = \csc \theta$ |
| b) $\tan^2 \theta + 1 = \sec^2 \theta$. | 8. $\csc(-\theta) \cos \theta = -\cot \theta$ |
| c) $\cot^2 \theta + 1 = \csc^2 \theta$. | 9. $\csc \theta \tan \theta = \sec \theta$ |
| d) $1 - \sec^2 \theta = -\tan^2 \theta$. | 10. $\frac{\sin \theta}{\csc \theta} = \sin^2 \theta$ |
| 4. a) $1 - \tan^2 \theta$ can't be simplified | 11. $\frac{\sec(-\theta)}{\csc \theta} = \tan \theta$ |
| b) $\csc^2 \theta - 1 = \cot^2 \theta$. | 12. $\frac{\tan(-\theta)}{\cot(-\theta)} = \tan^2 \theta$ |
| c) $\cos^2 \theta + \cot^2 \theta$ can't be simplified | 13. $\sin \theta \tan \theta - \sec \theta = -\cos \theta$ |
| d) $\sec^2 \theta - \csc^2 \theta$ can't be simplified | 14. $\sin \theta(\csc \theta - \sin \theta) = \cos^2 \theta$ |
| 5. a) $\sin^2 \theta - 1 = -\cos^2 \theta$. | 15. $\frac{\csc(-\theta)}{\cot \theta} = -\sec \theta$ |
| | 16. $\frac{1 + \tan^2(-\theta)}{1 + \cot^2 \theta} = \tan^2 \theta$ |

17. $\frac{1-\csc^2 \theta}{\sec^2 \theta - 1} = -\cot^4 \theta$

19. $\frac{1-\cos^2 \theta}{1+\tan^2 \theta} = \cos^2 \theta \sin^2 \theta$

18. $\frac{1+\tan(-\theta)}{\tan(-\theta)} = 1 - \cot \theta$

20. LHS: $\sec \theta = \frac{1}{\cos \theta}$;

RHS: $\csc \theta \tan \theta = \frac{1}{\sin \theta} \cdot \frac{\sin \theta}{\cos \theta} = \frac{1}{\cos \theta} = \text{LHS.}$

21. LHS: $\sin \theta(\sec \theta + \csc \theta) - 1 = \sin \theta \sec \theta + \sin \theta \csc \theta - 1 = \sin \theta \frac{1}{\cos \theta} + \sin \theta \frac{1}{\sin \theta} - 1 = \tan \theta + 1 - 1 = \tan \theta$;

RHS: $\tan \theta = \text{LHS.}$

22. LHS: $\sec(-\theta) \cot \theta \sin \theta = \sec \theta \cot \theta \sin \theta = \frac{1}{\cos \theta} \frac{\cos \theta}{\sin \theta} \sin \theta = 1$;

RHS: $1 = \text{LHS.}$

23. LHS: $\csc \theta = \frac{1}{\sin \theta}$;

RHS: $\sin \theta + \cot \theta \cos \theta = \sin \theta + \frac{\cos \theta}{\sin \theta} \cos \theta = \sin \theta + \frac{\cos^2 \theta}{\sin \theta} = \frac{\sin^2 \theta}{\sin \theta} + \frac{\cos^2 \theta}{\sin \theta} = \frac{\sin^2 \theta + \cos^2 \theta}{\sin \theta} = \frac{1}{\sin \theta} = \text{LHS.}$

24. LHS: $\frac{\sin \theta}{1 + \cos \theta} = \frac{(\sin \theta)(1 - \cos \theta)}{(1 + \cos \theta)(1 - \cos \theta)} = \frac{\sin \theta - \sin \theta \cos \theta}{1 - \cos^2 \theta} = \frac{\sin \theta - \sin \theta \cos \theta}{\sin^2 \theta} = \frac{\sin \theta}{\sin^2 \theta} - \frac{\sin \theta \cos \theta}{\sin^2 \theta} = \frac{1}{\sin \theta} - \frac{\cos \theta}{\sin \theta} = \csc \theta - \cot \theta$;

RHS: $\frac{1 - \cos \theta}{\sin \theta} = \frac{1}{\sin \theta} - \frac{\cos \theta}{\sin \theta} = \csc \theta - \cot \theta = \text{LHS.}$

25. LHS: $\frac{1 + \cos(-\theta)}{\sin \theta} = \frac{1 + \cos \theta}{\sin \theta} = \frac{1}{\sin \theta} + \frac{\cos \theta}{\sin \theta} = \csc \theta + \cot \theta$;

RHS: $\frac{\tan \theta}{\sec \theta - 1} = \frac{\tan \theta(\sec \theta + 1)}{(\sec \theta - 1)(\sec \theta + 1)} = \frac{\tan \theta \sec \theta + \tan \theta}{\sec^2 \theta - 1} = \frac{\tan \theta \sec \theta + \tan \theta}{\tan^2 \theta} = \frac{\tan \theta \sec \theta}{\tan^2 \theta} + \frac{\tan \theta}{\tan^2 \theta} = \frac{\sec \theta}{\tan \theta} + \frac{1}{\tan \theta} = \frac{1}{\cos \theta} \div \frac{\sin \theta}{\cos \theta} + \cot \theta = \frac{1}{\cos \theta} \cdot \frac{\cos \theta}{\sin \theta} + \cot \theta = \frac{1}{\sin \theta} + \cot \theta = \csc \theta + \cot \theta = \text{LHS.}$

26. LHS: $\sec \theta - \csc \theta = \frac{1}{\cos \theta} - \frac{1}{\sin \theta} = \frac{\sin \theta}{\cos \theta \sin \theta} - \frac{\cos \theta}{\sin \theta \cos \theta} = \frac{\sin \theta - \cos \theta}{\sin \theta \cos \theta}$;

RHS: $\frac{\sin \theta - \cos \theta}{\sin \theta \cos \theta} = \text{LHS.}$

27. LHS: $\sec^4 \theta - \sec^2 \theta = \sec^2 \theta(\sec^2 \theta - 1) = \sec^2 \theta \tan^2 \theta$;

RHS: $\tan^4 \theta + \tan^2 \theta = \tan^2 \theta(\tan^2 \theta + 1) = \tan^2 \theta \sec^2 \theta = \text{LHS.}$

28. LHS: $\frac{\tan(-\theta)}{\sec(-\theta)} = \frac{-\tan \theta}{\sec \theta} = -\frac{\sin \theta}{\cos \theta} \div \frac{1}{\cos \theta} = -\frac{\sin \theta}{\cos \theta} \cdot \frac{\cos \theta}{1} = -\sin \theta$;

RHS: $\sin(-\theta) = -\sin \theta = \text{LHS.}$

§7.2: Sum and difference identities

Note: Every question in this section is NC.

1. Suppose $\sin \alpha = \frac{2}{3}$ and α is in Quadrant I. Compute $\sin(\alpha + 60^\circ)$, and then draw a picture to explain what you just computed.
2. Suppose $\cos \alpha = -\frac{1}{4}$ and α is in Quadrant III. Compute $\cos(240^\circ - \alpha)$, and then draw a picture to explain what you just computed.
3. Suppose $\tan \theta = \frac{1}{3}$ and θ is in Quadrant I. Compute $\tan\left(\theta + \frac{2\pi}{3}\right)$, and then draw a picture to explain what you just computed.
4. Find a general formula for $\tan(\theta - 45^\circ)$, in terms of $\tan \theta$.
5. Suppose $\sin \alpha = \frac{1}{5}$, $\sin \beta = \frac{2}{3}$.
 - a) If both α and β are in Quadrant I, compute $\sin(\alpha + \beta)$.
 - b) If α is in Quadrant I but β is in Quadrant II, compute $\cos(\beta - \alpha)$.
6. Suppose $\cos \alpha = -\frac{5}{7}$ and $\sin \beta = \frac{3}{4}$.
 - a) If $\sin \alpha < 0$ and $\cos \beta > 0$, compute $\sin(\alpha - \beta)$.
 - b) If $\sin \alpha > 0$ and $\cos \beta < 0$, compute $\cos(\alpha + \beta)$.
7. Suppose $\tan \alpha = 3$ and $\tan \beta = \frac{2}{5}$.
 - a) Compute $\tan(\alpha + \beta)$.
 - b) Compute $\tan(\alpha - \beta)$.
 - c) What quadrant or quadrants could $\alpha + \beta$ belong to?
 - d) If $\cos(\alpha + \beta) > 0$, compute $\cos(\alpha + \beta)$.
8. Find the exact value (no decimals) of $\cos 15^\circ$.
9. Find the exact value (no decimals) of $\sin -75^\circ$.
10. Find the exact value (no decimals) of $\sec 165^\circ$.
11. Find the exact value (no decimals) of $\tan 105^\circ$.
12. Find the exact value (no decimals) of $\cos 195^\circ$.

13. Simplify each expression, by recognizing it as the complicated side of one of the trig identities encountered in this section:

a) $\sin 25^\circ \cos 35^\circ + \cos 25^\circ \sin 35^\circ$

b) $\cos 40^\circ \cos 140^\circ - \sin 140^\circ \sin 40^\circ$

c) $\frac{\tan 50^\circ - \tan 20^\circ}{1 + \tan 50^\circ \tan 20^\circ}$

Answers

As usual, the pictures are omitted - ask me about these if you have questions.

1. $\sin(\alpha + 60^\circ) = \frac{1}{3} + \frac{\sqrt{15}}{6}$.

3. $\tan\left(\theta + \frac{2\pi}{3}\right) = \frac{\frac{1}{3} - \sqrt{3}}{1 - \frac{1}{3}(-\sqrt{3})} = \frac{1 - 3\sqrt{3}}{3 + \sqrt{3}}$.

2. $\cos(240^\circ - \alpha) = \frac{1}{8} - \frac{\sqrt{45}}{8}$.

4. $\tan(\theta - 45^\circ) = \frac{\tan \theta + 1}{1 - \tan \theta}$.

5. a) $\sin(\alpha + \beta) = \frac{1}{5} \cdot \frac{\sqrt{5}}{3} + \frac{\sqrt{24}}{5} \cdot \frac{2}{3} = \boxed{\frac{\sqrt{5} + 2\sqrt{24}}{15}}$.

b) $\cos(\beta - \alpha) = -\frac{\sqrt{5}}{3} \cdot \frac{\sqrt{24}}{5} + \frac{1}{5} \cdot \frac{2}{3} = \boxed{\frac{-\sqrt{120} + 2}{15}}$.

6. a) $\sin(\alpha - \beta) = \frac{-\sqrt{24}}{7} \cdot \frac{\sqrt{7}}{4} - \frac{3}{4} \left(\frac{-5}{7}\right) = \boxed{\frac{-\sqrt{168} + 15}{28}}$.

b) $\cos(\alpha + \beta) = -\frac{5}{7} \cdot -\frac{\sqrt{7}}{4} - \frac{\sqrt{24}}{7} \cdot \frac{3}{4} = \boxed{\frac{5\sqrt{7} - 3\sqrt{24}}{28}}$.

7. a) $\tan(\alpha + \beta) = \frac{3 + \frac{2}{5}}{1 - 3(\frac{2}{5})} = \frac{\frac{17}{5}}{\frac{-1}{5}} = \boxed{-17}$.

b) $\tan(\alpha - \beta) = \frac{3 - \frac{2}{5}}{1 + 3(\frac{2}{5})} = \frac{\frac{13}{5}}{\frac{11}{5}} = \boxed{\frac{13}{11}}$.

c) $\alpha + \beta$ is in Quadrant II or IV, since $\tan(\alpha + \beta) < 0$.

d) $\cos(\alpha + \beta) = \boxed{\frac{1}{\sqrt{290}}}$.

8. $\cos 15^\circ = \frac{\sqrt{2} + \sqrt{6}}{4}$.

12. $\cos 195^\circ = \frac{-\sqrt{2} - \sqrt{6}}{4}$.

9. $\sin -75^\circ = \frac{-\sqrt{2} - \sqrt{6}}{4}$.

13. a) $\frac{\sqrt{3}}{2}$

10. $\sec 165^\circ = \sqrt{2} - \sqrt{6}$.

b) -1

11. $\tan 105^\circ = -2 - \sqrt{3}$.

c) $\frac{1}{\sqrt{3}}$

§7.3: More identities

Note: Every question in this section is NC.

1. Suppose $\sin \theta = \frac{2}{5}$ and $\cos \theta < 0$. Compute $\sin 2\theta$ and $\cos 2\theta$.
2. Suppose $\tan \theta = \frac{5}{3}$ and $\cos \theta < 0$. Compute $\tan 2\theta$ and $\tan \frac{\theta}{2}$.
3. Suppose $\cos \theta = \frac{3}{4}$. What are the possible values of $\cos \frac{\theta}{2}$?
4. Suppose $\cos 2\theta = \frac{3}{5}$ and θ is in Quadrant I. Compute $\cos \theta$.
5. Compute the exact value of all six trig functions of $\frac{3\pi}{8}$.
6. Verify the following “power-reducing” identity, which is used in Calculus 2 to simplify trig expressions:

$$\cos^2 \theta = \frac{1 + \cos 2\theta}{2}$$

7. Verify the following “power-reducing” identity, which is used in Calculus 2 to simplify trig expressions:

$$\sin^2 \theta = \frac{1 - \cos 2\theta}{2}$$

8. Find and verify an identity which writes $\sin 3\theta$ in terms of only the trig function $\sin \theta$.
9. Find and verify an identity which writes $\cos 4\theta$ in terms of only the trig function $\cos \theta$.
10. Simplify each expression, by recognizing it as the complicated side of one of the trig identities encountered in this section:

a) $2 \sin 22.5^\circ \cos 22.5^\circ$

b) $\cos^2 75^\circ - \sin^2 75^\circ$

Answers

1. $\sin 2\theta = -\frac{4\sqrt{21}}{25}$; $\cos 2\theta = \frac{17}{25}$

$$\tan \frac{\theta}{2} = \frac{1 - \frac{3}{\sqrt{34}}}{\frac{5}{\sqrt{34}}} = \frac{\sqrt{34} - 3}{5}$$

2. $\tan 2\theta = -\frac{15}{8}$

3. $\cos \frac{\theta}{2} = \pm \sqrt{\frac{7}{8}}$

4. $\frac{2}{\sqrt{5}}$

5. $\cos \frac{3\pi}{8} = \frac{\sqrt{2-\sqrt{2}}}{2}; \sin \frac{3\pi}{8} = \frac{\sqrt{2+\sqrt{2}}}{2};$

$\tan \frac{3\pi}{8} = \sqrt{\frac{2+\sqrt{2}}{2-\sqrt{2}}}; \cot \frac{3\pi}{8} = \sqrt{\frac{2-\sqrt{2}}{2+\sqrt{2}}};$

$\sec \frac{3\pi}{8} = \frac{2}{\sqrt{2-\sqrt{2}}}; \csc \frac{3\pi}{8} = \frac{2}{\sqrt{2+\sqrt{2}}}.$

6. LHS: $\cos^2 \theta.$

RHS: $\frac{1+\cos 2\theta}{2} = \frac{1+(2\cos^2 \theta - 1)}{2} = \frac{2\cos^2 \theta}{2} = \cos^2 \theta = \text{LHS}.$

7. LHS: $\sin^2 \theta.$

RHS: $\frac{1-\cos 2\theta}{2} = \frac{1-(1-2\sin^2 \theta)}{2} = \frac{2\sin^2 \theta}{2} = \sin^2 \theta = \text{LHS}.$

8.

$$\begin{aligned}
\sin 3\theta &= \sin(2\theta + \theta) \\
&= \sin 2\theta \cos \theta + \cos 2\theta \sin \theta \\
&= (2\sin \theta \cos \theta) \cos \theta + (\cos^2 \theta - \sin^2 \theta) \sin \theta \\
&= 2\sin \theta \cos^2 \theta + \cos^2 \theta \sin \theta - \sin^3 \theta \\
&= 3\cos^2 \theta \sin \theta - \sin^3 \theta = 3(1 - \sin^2 \theta) \sin \theta - \sin^3 \theta \\
&= 3\sin \theta - 3\sin^3 \theta - \sin^3 \theta \\
&= \boxed{3\sin \theta - 4\sin^3 \theta}.
\end{aligned}$$

9.

$$\begin{aligned}
\cos 4\theta &= \cos 2(2\theta) \\
&= \cos^2(2\theta) - \sin^2(2\theta) \\
&= [\cos 2\theta]^2 - [\sin 2\theta]^2 \\
&= [\cos^2 \theta - \sin^2 \theta]^2 - [2\sin \theta \cos \theta]^2 \\
&= [\cos^4 \theta - 2\sin^2 \theta \cos^2 \theta + \sin^4 \theta] - 4\sin^2 \theta \cos^2 \theta \\
&= \cos^4 \theta - 6\sin^2 \theta \cos^2 \theta + (\sin^2 \theta)^2 \\
&= \cos^4 \theta - 6(1 - \cos^2 \theta) \cos^2 \theta + (1 - \cos^2 \theta)^2 \\
&= \cos^4 \theta - 6\cos^2 \theta + 6\cos^4 \theta + (1 - 2\cos^2 \theta + \cos^4 \theta) \\
&= \boxed{8\cos^4 \theta - 8\cos^2 \theta + 1}.
\end{aligned}$$

10. a) $\frac{\sqrt{2}}{2}$

b) $\frac{\sqrt{3}}{2}$